

DS11 Series SSR For DC Loads up to 2A @ 60Vdc

Product Facts

- Standard options: short circuit/overload protection, switch status and trip status
- Optically coupled all solid state relay
- TTL & CMOS compatible input
- Low on-resistance power MOSFET output
- Tested per MIL-PRF-28750D and approved to DSCC drawing 88062 with "Y" level screening



DS11 series SSRs feature state of the art photo-voltaic optical isolation and power MOSFET output chips for ultra-reliable high speed switching of DC loads up to 2 amps, with extremely low on-resistance. Standard options include integral current overload/short circuit protection to provide protection of the relay, load

and wiring; and isolated switch status or trip status. The overload feature provides protection if a short or overload develops while the relay is in the on state or if the relay is turned on into a dead short. Switch status, optically isolated from the load, signals the status of the output and provides a logic "0" when the output

is off and a logic "1" when the output is on. Trip status, also optically isolated from the load, provides a logic "1" if the output trips off and a logic "0" when the output is in a normal condition, on or off, and is available only in conjunction with short circuit protection.

KILOVAC Part No.	DSCC Dwg. No.	Relay Version
DS11-1Y	88062-008	Basic relay
DS11-1000	88062-004	Relay w/ short circuit protection
DS11-1001	88062-006	Relay w/ switch status
DS11-1002	88062-002	Relay w/ short circuit protection and switch status
DS11-1003	N/A	Relay w/ short circuit protection and trip status

2 Terminal Input Configuration

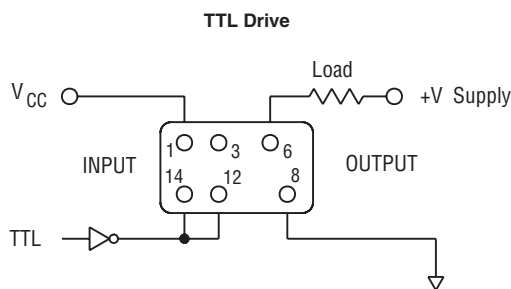
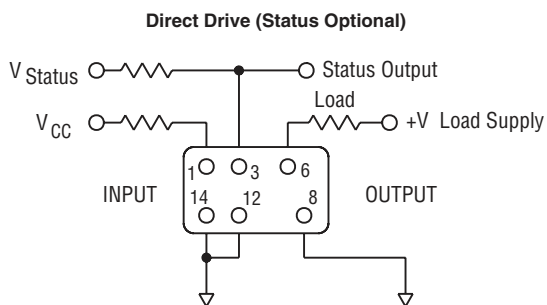

3 Terminal Input Configuration

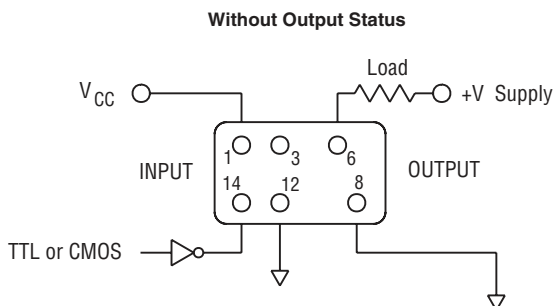
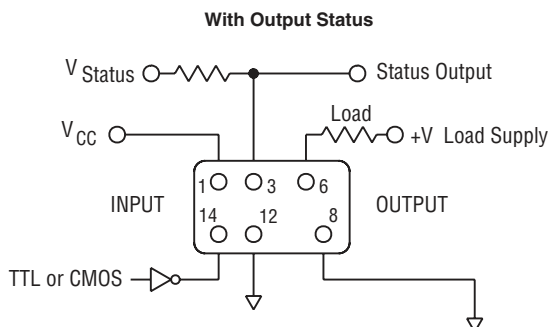

DS11 Series SSR For DC Loads up to 2A @ 60Vdc (Continued)

Environmental Characteristics

Ambient Temperature Range —

Operating — -55°C to +105°C
Storage — -55°C to +105°C

Vibration Resistance —

100 G's, 10-3,000 Hz

Shock Resistance —

50 G's, 11 ms pulse

Constant Acceleration Resistance

(Y1 axis) —

5,000 G's

Mechanical Characteristics

Weight (approx.) —

.176 oz. (5 grams)

Materials —

Header — KOVAR

Cover — Nickel

Pins — KOVAR, gold plated

Electrical Specifications (-55°C to +105°C unless otherwise specified)

Input (2 terminal configuration)

Input supply voltage range (Vcc)	3.8 - 32 Vdc (Notes 1 & 2, Figures 1 & 2)
Input current (max.) @ 5Vdc	15mAdc (Notes 1 & 2, Figures 1 & 2)
Must turn-on voltage	3.8Vdc
Must turn-off voltage	1.5Vdc
Reverse voltage protection	-32Vdc

Input (3 terminal configuration)

Control voltage range	0 - 18 Vd
Control current (max.)	250µAdc @ 5V, 1mA @ 18V
Input supply voltage range (Vcc)	3.8 - 32 Vdc (Notes 1 & 2, Figures 1 & 2)
Input current (max.) @ 5Vdc	15mADC (Notes 1 & 2, Figures 1 & 2)
Must turn-on voltage	0.3Vdc
Must turn-off voltage	3.2Vdc

I/O

Dielectric strength (min.)	1,000V rms
Insulation resistance (min.) @ 500Vdc	10 ⁹ ohms
Capacitance (max.)	10pF

Output

Continuous load current (max.) @ 25°C	2.1Adc (Figure 7)
Continuous load voltage (max.)	60Vdc
Transient blocking voltage (max.)	80Vdc (Note 5)
On resistance (max.) @ T _j = 25°C, I _L = 100mA	0.15 ohm (Note 6, Figure 6)
Output voltage drop (max.)	0.5Vdc
Leakage current (max.) @ V = 60Vdc	100µAdc
Leakage current (max.) @ V = 60Vdc, with switch status	2mAdc
Turn-on time (max.)	3 ms (Figure 3)
Turn-off time (max.)	1 ms (Figure 3)
dv/dt (min.)	100V / µs
Electrical system spike	600Vdc (Note 5)
Output chip junction temperature (max.)	125°C
Thermal resistance (max.), junction to ambient	90°C/W
Thermal resistance (max.), junction to case	25°C/W

Status

Status supply voltage range	1 - 18Vdc
Status current (max.) @ V _{status} ≤ 0.4Vdc	600µADC (Figure 5, Note 8)
Status leakage current (max.) @ 16Vdc	10µAdc
Status turn-on time (max.)	3.5 ms (Figure 4)
Status turn-off time (max.)	8 ms (Figure 4)

Short Circuit Protection

Current surge without tripping (max.), 100ms pulse	4.25Adc
Overload trip current (max.), 0.5 ms pulse, V = 60Vdc	10Adc
Trip time (typical), turning on into short	400µs
Trip time (typical), shorting while relay is on	280µs

10

KILOVAC Solid State Relays

DS11 Series SSR For DC Loads up to 2A @ 60Vdc (Continued)

Figure 1 - Maximum Input Current vs. Input Voltage

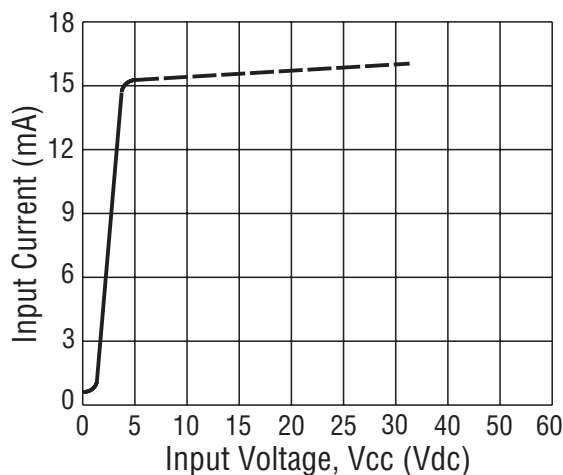

Figure 2 - Series Resistance vs. Vcc Supply Voltage (Note 1)

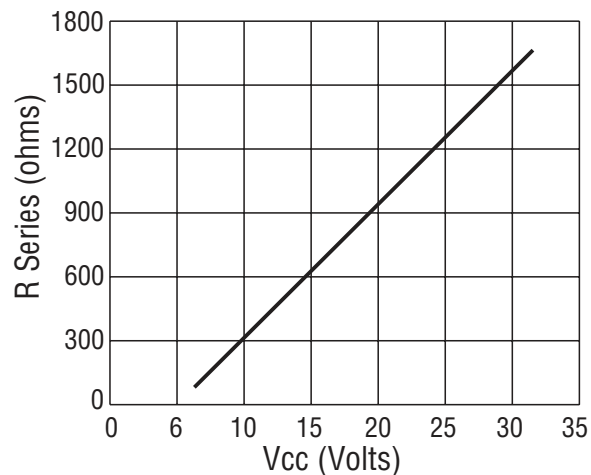

Figure 3 - Turn-on and Turn-off Timing

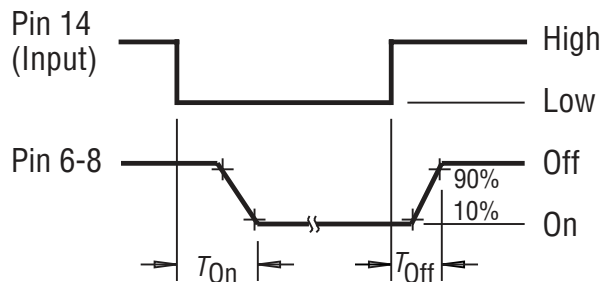

Figure 4 - Output Status Timing

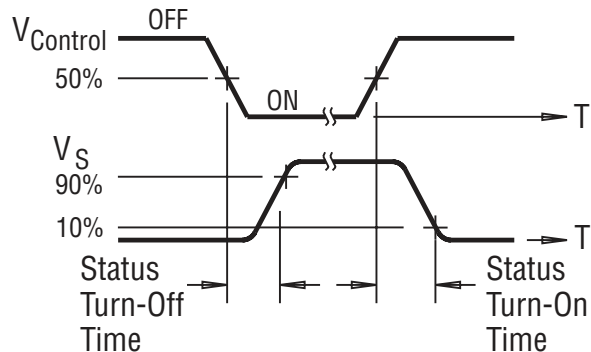

Figure 5 - Status Resistor vs. Status Supply Voltage

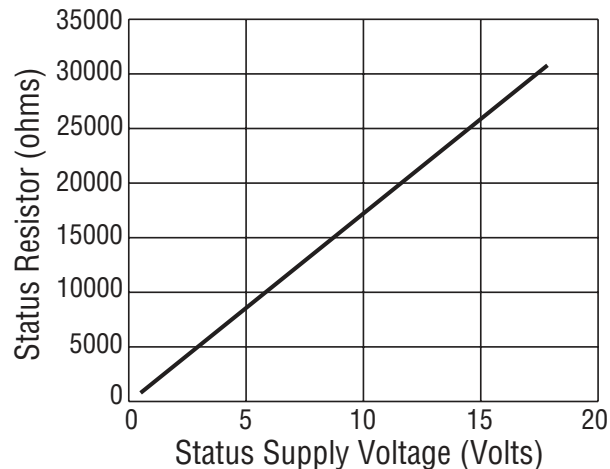
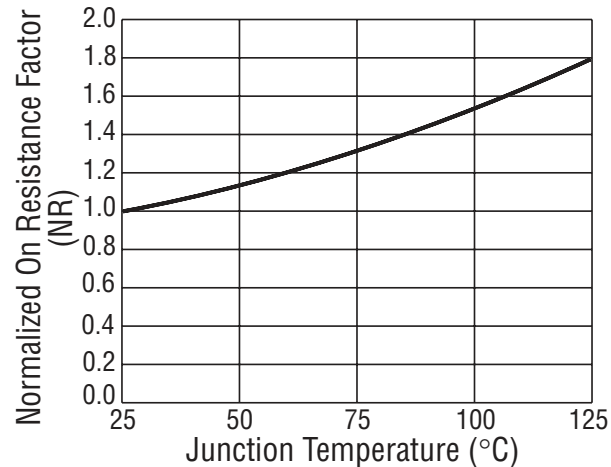

Figure 6 - On-Resistance vs. Temperature (Note 6)



DS11 Series SSR For DC Loads up to 2A @ 60Vdc (Continued)

Figure 7 - Temperature Derating Curve

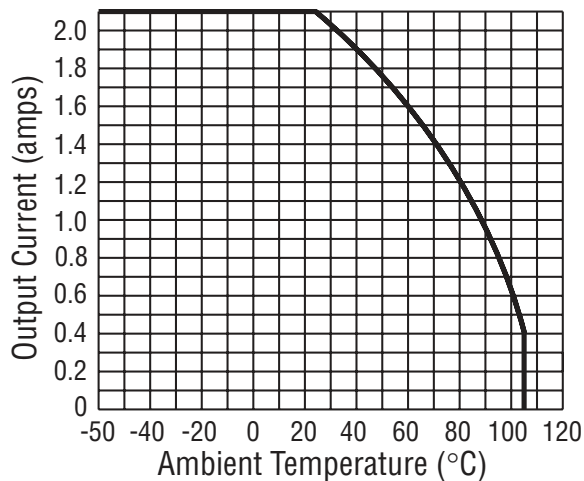

Figure 8 - Maximum Surge Current Without Tripping

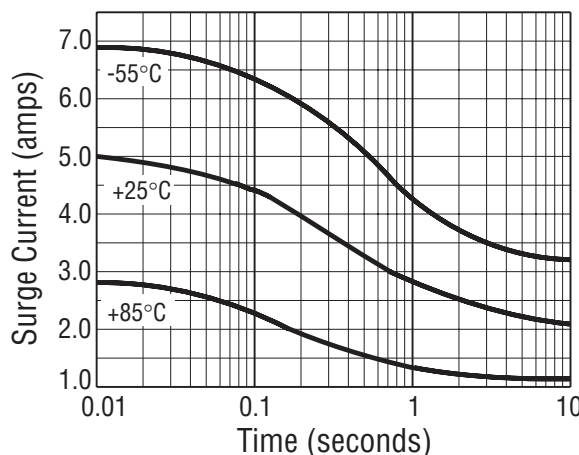
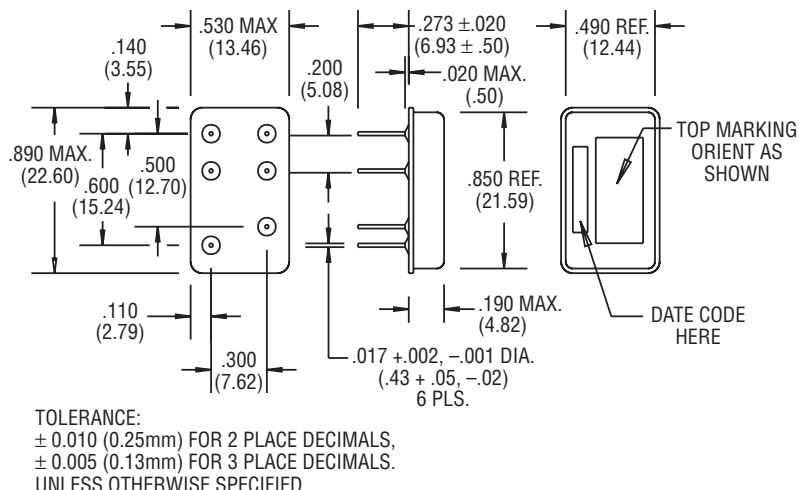

Figure 9 - Outline Dimensions



Notes

- 2 terminal input configuration is compatible with CMOS or open collector TTL (with pull-up resistor). For Vcc levels above 6Vdc, a series limiting resistor is required. See Fig. 2 for resistor value. Use standard resistor value equal to or less than value from the curve.
- Input transitions to be ≤ 1ms duration, and input direct drive should be "bounceless contact" type.
- Vcc = 5Vdc for all tests unless otherwise specified.
- All DS11 Series relays may drive loads connected to either positive or negative referenced power supply lines. Reversing polarity of output may cause permanent damage. Inductive loads must be diode suppressed.
- Transient blocking voltage and electrical system spike tests are performed per MIL-STD-704 (28VDC systems).
- To determine the maximum on-resistance at any given junction temperature, multiply on-resistance at 25°C (0.15 ohm) by normalized on-resistance factor from curve (Fig. 6).
- Overload testing per MIL-R-28750 is constrained to the limits imposed by the short circuit protection requirements of this specification and DSCC drawing 88062. Load circuit series inductance for "load shorted" mode of operation to be limited to 50mH max. Maximum repetition rate into a shorted load should not exceed 10 Hz.
- Proper operation of the status feedback requires a status pull-up resistor. See Fig. 5 for status resistor value.