

**STRAIGHT PLUG CLAMP TYPE  
CABLE 10 +11/50**

**R185.010.000**  
**SERIES 7-16**

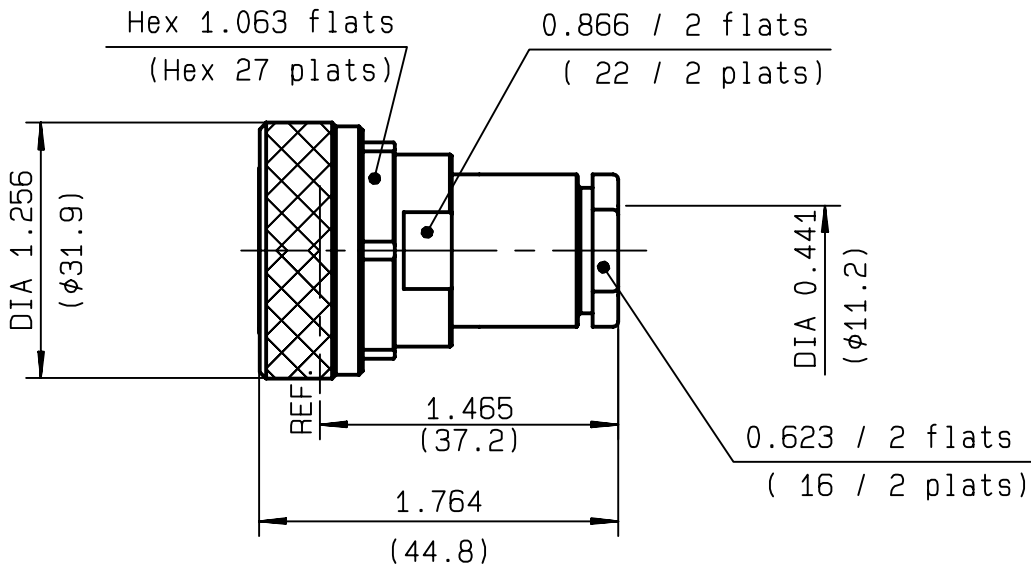

NOMINAL IMPEDANCE	<b>50</b> Ω
FREQUENCY RANGE	<b>0-7.5</b> GHz
TEMPERATURE RATING	<b>-55/+155</b> °C
V.S.W.R	<b>1.20</b> + x F(GHz)Maxi
RF INSERTION LOSS	<b>0.05</b> √F(GHz) dB Maxi
VOLTAGE RATING	<b>1400</b> Veff Maxi
DIELECTRIC WITHSTANDING VOLTAGE	<b>2700</b> Veff Mini
INSULATION RESISTANCE	<b>10000</b> MΩMini
HERMETIC SEAL	<b>NA</b> Atm.cm <sup>3</sup> /s
LEAKAGE (pressurized only)	<b>NA</b>
MECHANICAL DURABILITY	<b>500</b> Cycles
WEIGHT	<b>101.1</b> gr
SPECIFICATION	

CABLES : **KX 13**  
**KX 4**  
**RG 213**  
**RG 214**  
**RG 225**

OTHERS CHARACTERISTICS

ROS	<b>1.10</b>	a 3 GHz
CABLE RETENTION	<b>250</b>	N Mini
CENTER CONTACT RETENTION		
Axial force - mating end	<b>200</b>	N Mini
Axial force - opposite end	<b>200</b>	N Mini
Torque	<b>NA</b>	cm.N Mini
RECOMMENDED TORQUES		
Mating	<b>3000</b>	cm.N
Panel nut	<b>NA</b>	cm.N
Clamp nut	<b>800</b>	cm.N

CONNECTOR PARTS	MATERIALS	FINISH	(all values are given in micrometers)
BODY	BRASS	BBR 0.5 OVER SILVER 3	
OUTER CONTACT	BRASS	SILVER 5 OVER COPPER 0.5	
CENTER CONTACT	BRASS	SILVER 5 OVER COPPER 0.5	
INSULATOR	PTFE	-	
GASKET	SILICONE RUBBER	-	
OTHERS PIECES	BRASS	BBR 2	

ISSUE **0224F00** CREATION DATE **11/05/1994** FILE PART-NUMBER **EPC96-02**



**RADIALL**®

GAUTIER

The information given here is subject to change without notice. Design changes may be in order to improve the product .

*Connect to the future*



**R185.010.000**

ISSUE 0224F00 SERIES 7-16

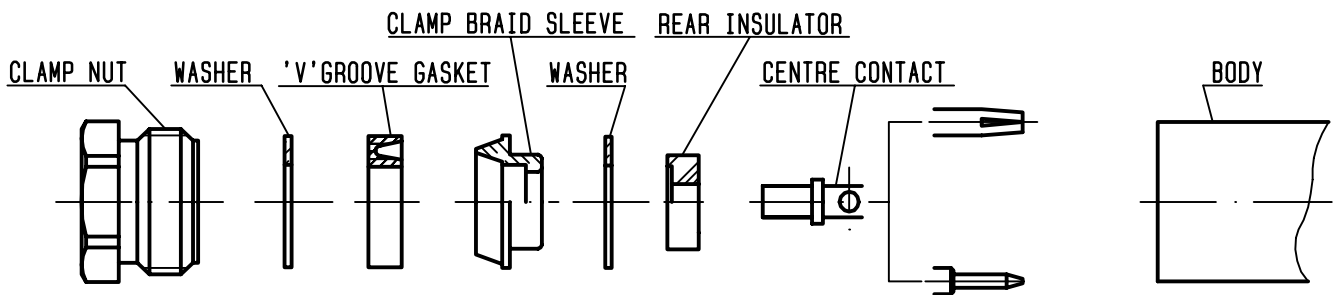

①

Strip the cable .

- 
- 
- 
- 

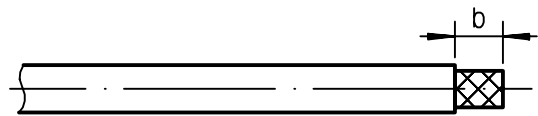

Stripping	a	b	c	d	e
inch	0.197	0.335	0	0	0.059
mm	5	8.5			1.5

②

Slide the clamp nut , the washer and the 'V' groove gasket onto the cable .  
 Slide clamp braid sleeve over braid .  
 Fold back braid and trim off surplus braid .  
 Trim back dielectric as shown .

- 
- 

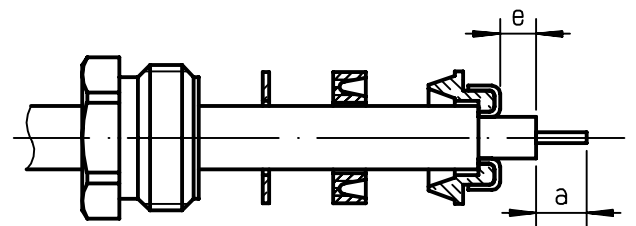

③

Mount washer and rear insulator .  
 Solder the cable inner conductor into centre contact .

- 
- 
- 
- 

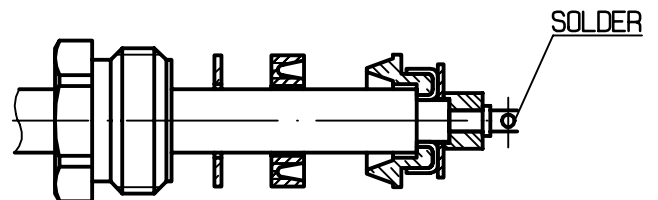

④

Screw sub-assembly into the connector body .  
 ( recommended coupling torque 70.87 in.lb )

- 

