

PART NUMBER	REV	FIRST USED
1385016-1	B	122500-1
1385016-2	B	565435-5
1385016-3	B	354500-1

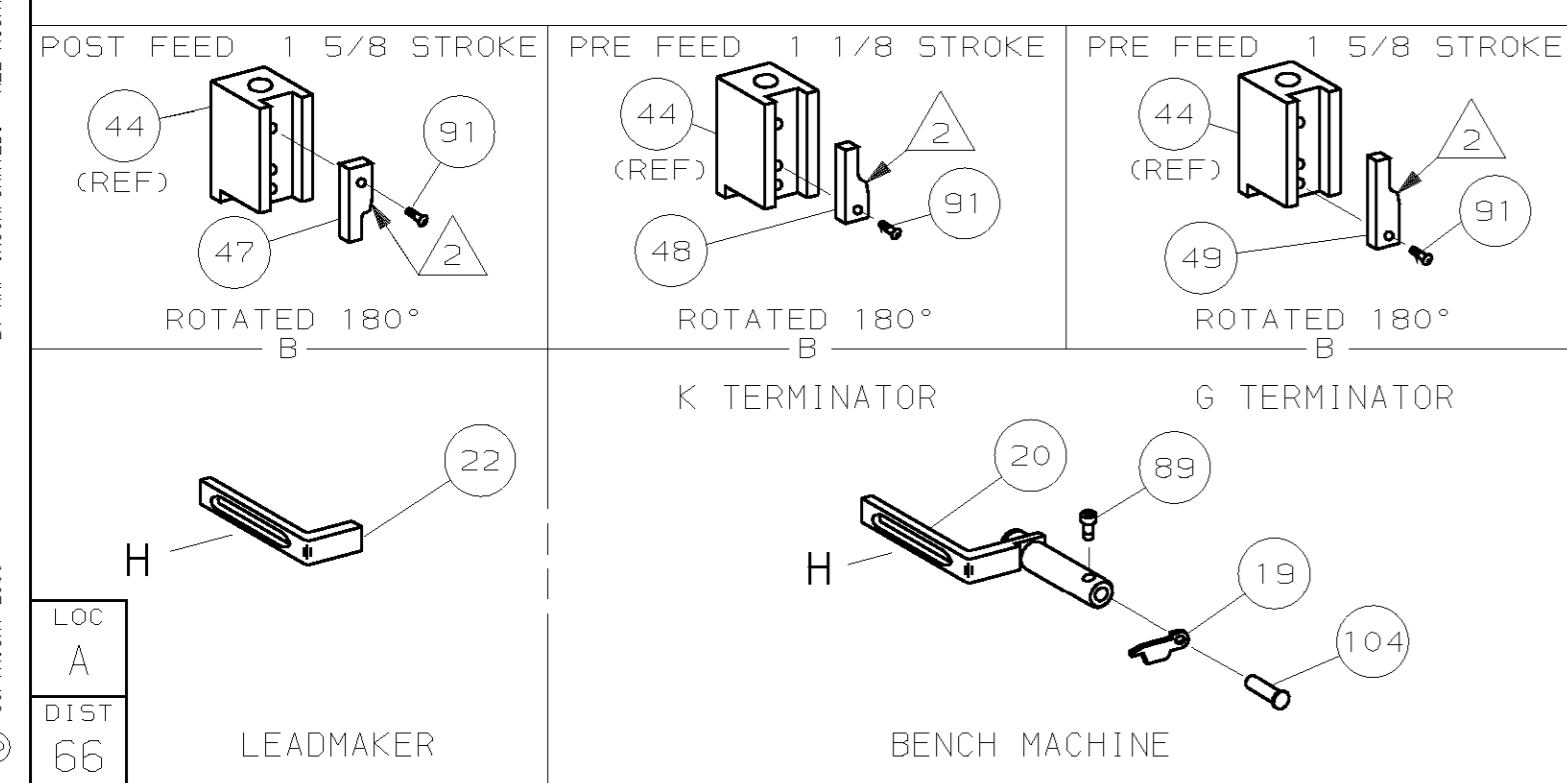
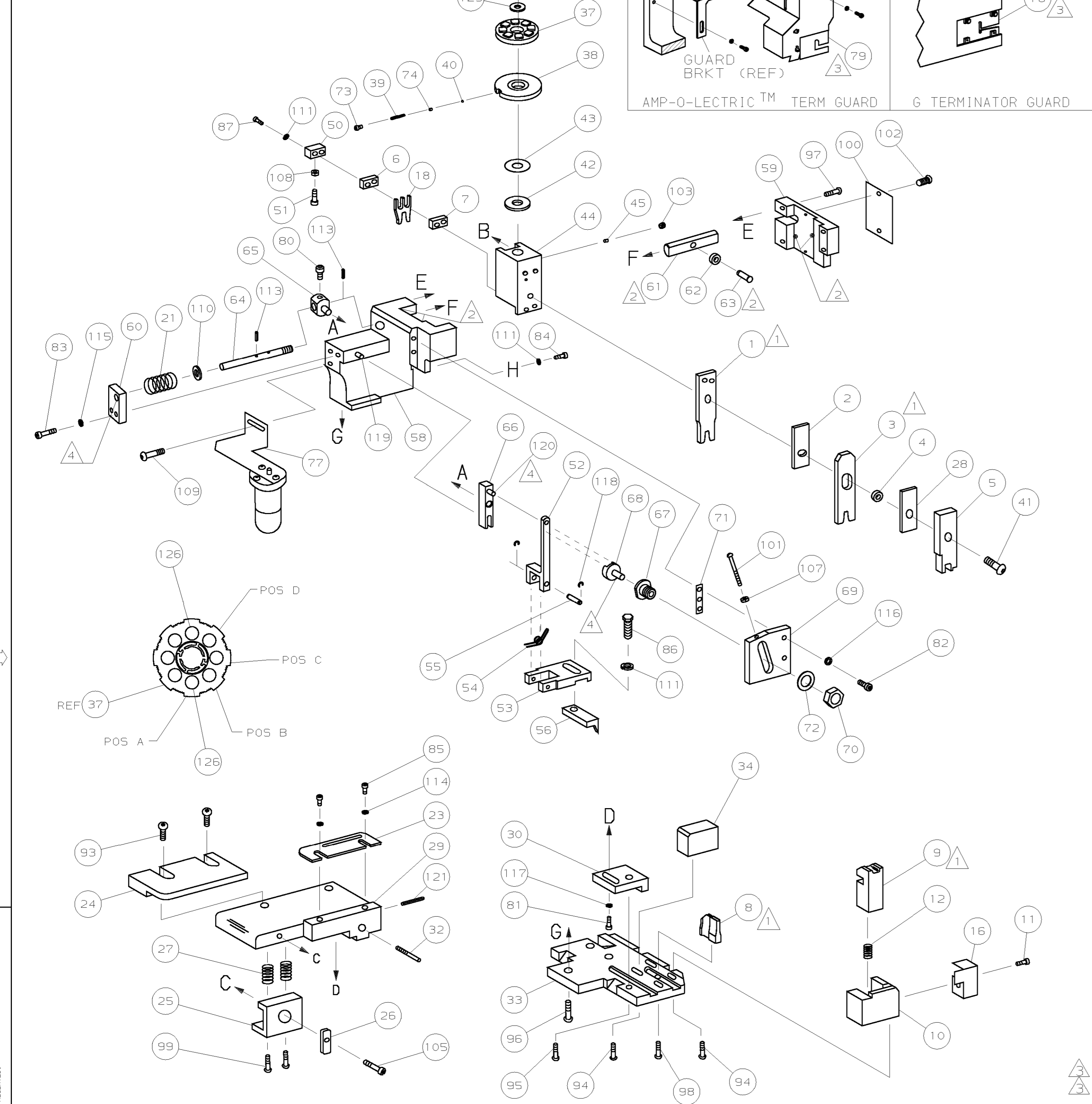

- 1 RECOMMENDED SPARE PARTS.
- 2 GREASE LIGHTLY.
- 3 GUARD MUST BE IN PLACE WHEN OPERATING APPLICATOR IN A BENCH MACHINE.
- 4 LUBRICATE DAILY USING NO. 20 MACHINE OIL.
- 5. ITEMS WITH QTY OF REF SPECIFIED (EXCEPT ITEMS 78 AND 79) ARE USED ON ITEM 46.

TERMINAL NAME: PIN BODY, TYPE III+ SIZE 16			
1-66131-7 CRIMP DATA (AMP TERMINAL)			
PAD LTR	CRIMP HEIGHT	WIRE SIZE	
A	.051 ±.002 [1.30 ±0.05mm]	18	
B	NOT	USED	
C	NOT	USED	
D	NOT	USED	
CRIMP	SIZE	TYPE	RANGE
WIRE	.080 [2.03mm]	F	18
INSUL	.120 [3.05mm]	0	φ.095 MAX

QTY	REF	REF	REF	U/M	DWG SIZE	PART NO	DESCRIPTION	ITEM NO
129								129
128								128
127								127
2	2	2	-	C		3-354779-4	PIN, WIRE DISC (.3160)A	126
1	1	1	-	A		986950-1	WASHER, FLAT PRECISION	125
1	1	1	-	A		217238-1	GENERAL INSTRUCTION PACKAGE	124
1	1	1	-	-		4088040	SF APPL INST 408-8040	123
1	1	1	-	-				122
1	1	1	-	A		4-21028-0	PIN,SLT SPR(φ.093x.75)ST GDE PL	121
REF	REF	REF	-	A		1-21030-1	PIN,DOWEL(φ.187x.50)LEVER	120
REF	REF	REF	-	A		1-21030-6	PIN,DOWEL(φ.187x.125)HOUSING	119
REF	REF	REF	-	A		21045-3	RING,RET "C"(φ.187)FD FING PIN	118
1	1	1	-	A		21024-5	WASHER, LOCK (#10)ADJ BLOCK	117
REF	REF	REF	-	A		21024-5	WASHER,LOCK(#10)ADJ PLATE	116
REF	REF	REF	-	A		21024-5	WASHER,LOCK(#10)FEED GDE ROD	115
2	2	2	-	A		21024-2	WASHER,LOCK(#4)FRONT STP GUIDE	114
REF	REF	REF	-	A		5-21028-1	PIN,SLT SPR(φ.125x.50)ADJ ROD	113
								112
4	4	4	-	A		21024-4	WASHER,LOCK(#8)STRIPPER	111
REF	REF	REF	-	A		21899-4	WASHER,FLAT(φ5/16)SCREW ADJ	110
-	1	-	-	A		2-21002-6	SCR,BHC(10-32x.38)LUBE ASSY	109
1	1	1	-	A		21018-5	NUT,HEX(NO.6)HOLDDOWN	108
REF	REF	REF	-	A		21068-5	NUT,HEX(6-32)FEED ADJ	107
								106
1	1	1	-	A		22353-8	SCR,SHLD(φ.187x.25)DRAG LEVER	105
1	1	-	-	A		992031-1	PIN, CLEVIS	104
1	1	1	-	A		21009-2	SCR,5KT SET(1/4-20x.25 LW)RAM	103
2	2	2	-	A		21017-2	SCR,DRIVE(#2x.19)ID PLATE	102
REF	REF	REF	-	A		6-23715-5	SCR,PAN HD(6-32x1.50)FEED ADJ	101
1	1	1	-	B		461264-1	PLATE, IDENTIFICATION	100
2	2	2	-	A		3-21002-0	SCR,BHC(10-32x.88)DRAG	99
1	1	1	-	A		22733-8	SCR,BHC(8-32x.38 LW)ANVIL	98
REF	REF	REF	-	A		2-21002-9	SCR,BHC(10-32x.75)CAP	97
REF	REF	REF	-	A		2-22733-8	SCR,BHC(1/4-20x.62)HOUSING	96
REF	REF	REF	-	A		2-21002-7	SCR,BHC(10-32x.50)56 ADJ BLOCK	95
4	4	4	-	A		2-21002-2	SCR,BHC(8-32x.50)STP H DWN	94
2	2	2	-	A		2-21002-3	SCR,BHC(8-32x.63)R STP GDE	93
								92
1	1	1	-	A		1-21002-7	SCR,BHC(6-32x.38)CAM	91
								90
1	1	-	-	A		7-21000-9	SCR,SHC(4-40x.19)STRIPPER	89
								88
2	2	2	-	A		2-21000-9	SCR,SHC(8-32x.75)DEP-HOLD	87
1	1	1	-	A		2-22603-0	SCR,HEX HD(8-32x.31)FEED FINGER	86
2	2	2	-	A		1-21000-3	SCR,SHC(4-40x.25)F ST GUIDE	85
1	1	1	-	A		2-21000-7	SCR,SHC(8-32x.50)STRIPPER	84
REF	REF	REF	-	A		3-21000-7	SCR,SHC(10-32x.75)FEED ROD GD	83
REF	REF	REF	-	A		3-21000-6	SCR,SHC(10-32x.62)FD ADJ BLK	82
1	1	1	-	A		3-21000-4	SCR,SHC(10-32x.38)56 ADJ BL	81
REF	REF	REF	-	A		3-21000-4	SCR,SHC(10-32x.38)PIVOT BLK	80
-	REF	-	-	B		455749-1	GUARD, WINDOW	79
REF	-	-	-	B		679532-1	INSERT, GUARD	78
-	1	-	-	C		1-465184-0	LUBRICATOR ASSY	77
								76
								75
1	1	1	-	A		690603-1	SPRING, ASSIST	74
1	1	1	-	A		23030-1	SCR,SHC(6-32x.25 SL)INS DISC	73
REF	REF	REF	-	A		458109-1	WASHER, SPECIAL	72
REF	REF	REF	-	A		690517-1	SPACER	71
								70
								69
								68
								67
								66
								65
								64
								63
								62
								61
								60
								59
								58
								57
								56
								55
								54
								53
								52
								51
								50
								49
								48
								47
								46
								45
								44
								43
								42
								41
								40
								39
								38
								37
								36
								35
								34
REF	REF	REF	-	D		455675-1	PLATE, BASE	33
1	1	1	-	A		690432-3	SCREW, ADJUSTMENT	32
								31
REF	REF	REF	-	B		455689-1	BLOCK, STRIP GUIDE ADJ	30
1	1	1	-	C		458144-1	PLATE, STRIP GUIDE	29
1	1	1	-	C		2-455888-1	SPACER, FRONT SHEAR DEP	28
2	2	2	-	A		1-22284-0	SPRING, DRAG	27
1	1	1	-	B		240793-1	LEVER, DRAG RELEASE	26
1	1	1	-	B		240792-1	DRAG, TERMINAL	25
1	1	1	-	D		90765-4	GUIDE, STRIP (REAR)	24
1	1	1	-	A		690438-1	GUIDE, STRIP (FRONT)	23
-	-	1	-	B		690472-2	STRIPPER	22
REF	REF	REF	-	A		4-22284-9	SPRING, FEED RETURN	21
1	1	-	-	A		679218-1	STRIPPER WIRE STOP ASSY	20
1	1	-	-	B		458949-1	STRIPPER	19
1	1	1	-	B		1338463-1	CRIMPER, SPECIAL	18
								17
1	1	1	-	B		318563-1	GUARD, CHIP, FRONT	16
								15
								14
								13
1	1	1	-	A		5-22280-0	SPRING, SHEAR	12
1	1	1	-	B		690461-1	STOP, SHEAR	11
1	1	1	-	C		690459-1	HOLDER, SHEAR (FRONT)	10
1	1	1	-	C		454276-1	SHEAR, FLOAT (FRONT)	9
1	1	1	-	C		1338462-1	ANVIL	8
1	1	1	-	C		6-240641-4	SPACER, DEPRESSOR (REAR)	7
1	1	1	-	C		2-240641-4	SPACER, DEPRESSOR (REAR)	6
1	1	1	-	C		1-455889-4	DEPRESSOR, SHEAR (FRONT)	5
1	1	1	-	B		2-238011-2	SPACER, BLOCK CRIMPER	4
1	1	1	-	C		2-456135-4	CRIMPER, INSULATION	3
1	1	1	-	C		455888-3	SPACER, CRIMPER	2
1	1	1	-	C		1-456405-6	CRIMPER, WIRE	1

QTY	REF	REF	REF	U/M	DWG SIZE	PART NO	DESCRIPTION	ITEM NO
1	1	1	-	A		690603-1	SPRING, ASSIST	74
1	1	1	-	A		23030-1	SCR,SHC(6-32x.25 SL)INS DISC	73
REF	REF	REF	-	A		458109-1	WASHER, SPECIAL	72
REF	REF	REF	-	A		690517-1	SPACER	71
								70
								69
								68
								67
								66
								65
								64
								63
								62
								61
								60
								59
								58
								57
								56
								55
								54
								53
								52
								51
								50
								49
								48
								47
								46
								45
								44
								43
								42
								41
								40
								39
								38
								37
								36
								35
								34
REF	REF	REF	-	D		455675-1	PLATE, BASE	33
1	1	1	-	A		690432-3	SCREW, ADJUSTMENT	32
								31
REF	REF	REF	-	B		455689-1	BLOCK, STRIP GUIDE ADJ	30
1	1	1	-	C		458144-1	PLATE, STRIP GUIDE	29
1	1	1	-	C		2-455888-1	SPACER, FRONT SHEAR DEP	28
2	2	2	-	A		1-22284-0	SPRING, DRAG	27
1	1	1	-	B		240793-1	LEVER, DRAG RELEASE	26
1	1	1	-	B		240792-1	DRAG, TERMINAL	25
1	1	1	-	D		90765-4	GUIDE, STRIP (REAR)	24
1	1	1	-	A		690438-1	GUIDE, STRIP (FRONT)	23
-	-	1	-	B		690472-2	STRIPPER	22
REF	REF	REF	-	A		4-22284-9	SPRING, FEED RETURN	21
1	1	-	-	A		679218-1	STRIPPER WIRE STOP ASSY	20
1	1	-	-	B		458949-1	STRIPPER	19
1	1	1	-	B				