

STarGRID™ ST7590T SoC PRIME-certified powerline communication development kit

Data brief

Features

- PRIME-certified powerline communication development kit based on STarGRID™ ST7590T PLC SoC
- Complete and certified EN50065 compliant reference design for modular and integrated PRIME-based application development
- Onboard STM32F103RG microcontroller for system management and application host controller
- AC power supply based on the ALTAIR04-900 quasi-resonant current mode SMPS controller
- RS232 / RS485 host interface to STM32F103RG microcontroller with opto-couplers for double insulation
- Intuitive graphical user interface (GUI)
- Suitable for CENELEC EN50065 and FCC part 15 compliant applications



industrial implementation and customization, as well as to provide ready and customizable solutions for any special, low-volume application.

Description

Based on the ST7590 powerline communication system-on-chip, the EVALST7590T-2 development kit embeds all the functions required for a turnkey powerline communication network: the PLC node is based on the ST7590T device, the AC power supply is based on the ALTAIR4-900 SMPS controller and the STM32F103RG microcontroller, to either control the system as a standalone application or to connect the EVALST7590T-2 to an external host.

The EVALST7590T-2 embeds ST's full PRIME-compliant protocol stack and provides a complete reference for PRIME-based applications such as smart meters or concentrators, and is an ideal standalone tool for in-field PRIME network tests.

The EVALST7590T-2 kit supports DLMS/COSEM libraries and has been jointly developed by ST and Fideltronik to accelerate high-volume

1 Schematic diagram

Figure 1. EVALST7590T-2 block diagram

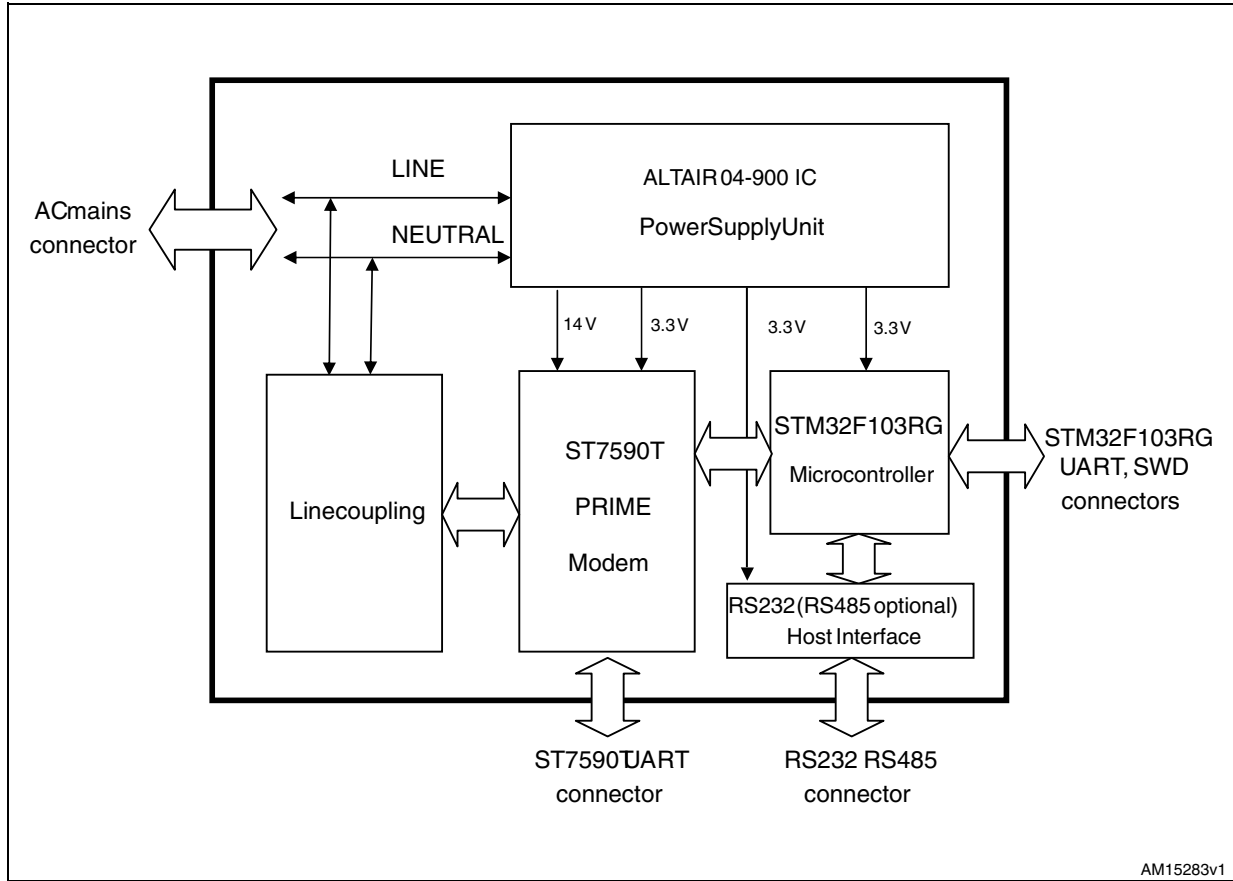

2 Revision history

Table 1. Document revision history

Date	Revision	Changes
19-Nov-2012	1	Initial release.

Please Read Carefully:

Information in this document is provided solely in connection with ST products. STMicroelectronics NV and its subsidiaries ("ST") reserve the right to make changes, corrections, modifications or improvements, to this document, and the products and services described herein at any time, without notice.

All ST products are sold pursuant to ST's terms and conditions of sale.

Purchasers are solely responsible for the choice, selection and use of the ST products and services described herein, and ST assumes no liability whatsoever relating to the choice, selection or use of the ST products and services described herein.

No license, express or implied, by estoppel or otherwise, to any intellectual property rights is granted under this document. If any part of this document refers to any third party products or services it shall not be deemed a license grant by ST for the use of such third party products or services, or any intellectual property contained therein or considered as a warranty covering the use in any manner whatsoever of such third party products or services or any intellectual property contained therein.

UNLESS OTHERWISE SET FORTH IN ST'S TERMS AND CONDITIONS OF SALE ST DISCLAIMS ANY EXPRESS OR IMPLIED WARRANTY WITH RESPECT TO THE USE AND/OR SALE OF ST PRODUCTS INCLUDING WITHOUT LIMITATION IMPLIED WARRANTIES OF MERCHANTABILITY, FITNESS FOR A PARTICULAR PURPOSE (AND THEIR EQUIVALENTS UNDER THE LAWS OF ANY JURISDICTION), OR INFRINGEMENT OF ANY PATENT, COPYRIGHT OR OTHER INTELLECTUAL PROPERTY RIGHT.

UNLESS EXPRESSLY APPROVED IN WRITING BY TWO AUTHORIZED ST REPRESENTATIVES, ST PRODUCTS ARE NOT RECOMMENDED, AUTHORIZED OR WARRANTED FOR USE IN MILITARY, AIR CRAFT, SPACE, LIFE SAVING, OR LIFE SUSTAINING APPLICATIONS, NOR IN PRODUCTS OR SYSTEMS WHERE FAILURE OR MALFUNCTION MAY RESULT IN PERSONAL INJURY, DEATH, OR SEVERE PROPERTY OR ENVIRONMENTAL DAMAGE. ST PRODUCTS WHICH ARE NOT SPECIFIED AS "AUTOMOTIVE GRADE" MAY ONLY BE USED IN AUTOMOTIVE APPLICATIONS AT USER'S OWN RISK.

Resale of ST products with provisions different from the statements and/or technical features set forth in this document shall immediately void any warranty granted by ST for the ST product or service described herein and shall not create or extend in any manner whatsoever, any liability of ST.

ST and the ST logo are trademarks or registered trademarks of ST in various countries.

Information in this document supersedes and replaces all information previously supplied.

The ST logo is a registered trademark of STMicroelectronics. All other names are the property of their respective owners.

© 2012 STMicroelectronics - All rights reserved

STMicroelectronics group of companies

Australia - Belgium - Brazil - Canada - China - Czech Republic - Finland - France - Germany - Hong Kong - India - Israel - Italy - Japan - Malaysia - Malta - Morocco - Philippines - Singapore - Spain - Sweden - Switzerland - United Kingdom - United States of America

www.st.com