

**Order Number
203702-0400**

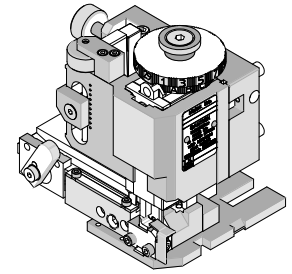

Application Tooling Specification

FEATURES

- Quick punch removal with the push of a button for fast and easy tooling change
- Applicator designed to industry-standard mounting and 135.80mm (5.346”) shut height
- Quick setup time; plus, the crimp height, track and feed adjustments can be set without removing the applicator from the press
- Fine adjustment allows users to achieve target with little effort by adjusting in increments of 0.015mm (.0006”) for conductor crimp height and 0.063mm (.0025”) for insulation height
- Independent adjustment rings allow users to quickly adjust the conductor or insulation crimp height without affecting each other
- Directly adapts to most automatic wire processing machines

SCOPE

Products: Spot-On 1.5 Female Crimp Terminals, 24-28 AWG.

Terminal Series No.	Terminal Order No.	Wire		Insulation Diameter (1)		Strip Length	
		AWG	Type	mm	In.	mm	In.
201649	201649-5000	24	UL1061	1.05-1.15	.041-.045	1.50-1.90	.059-.075
		26	UL1061	0.95-1.05	.037-.041		
		28	UL1061	0.85-0.95	.033-.037		
(1) Overall insulation OD specification for terminal.							

DEFINITION OF TERMS

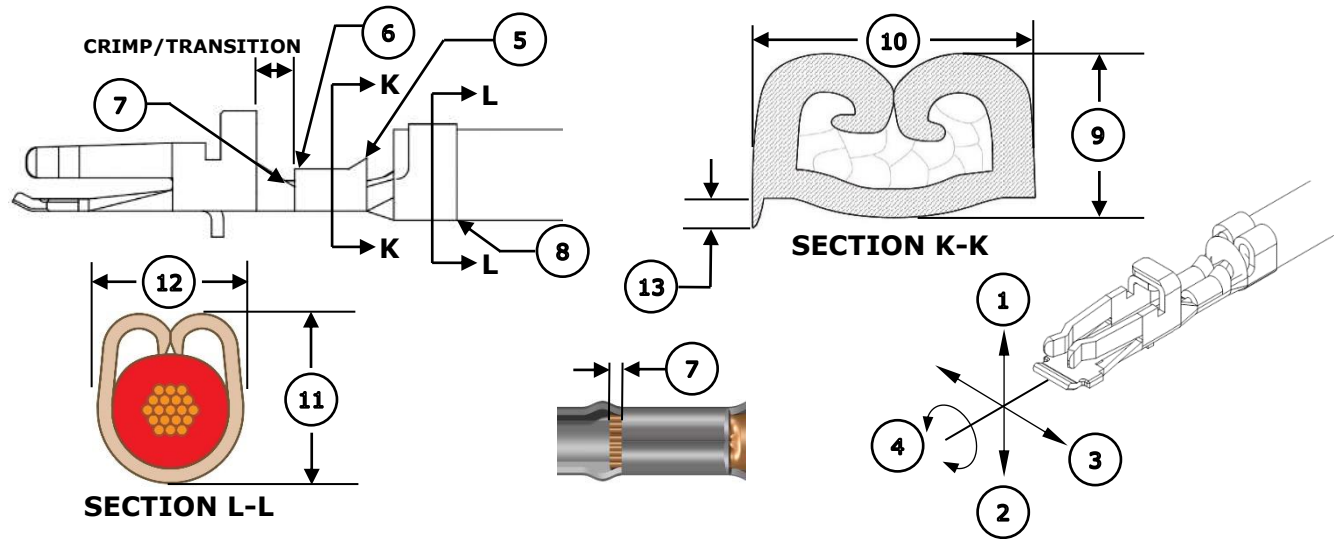

CRIMP SPECIFICATION

Feature	Requirement					
1. Bend Up	3° Max					
2. Bend Down	2° Max					
3. Twist	3° Max					
4. Roll	6° Max					
5. Bell Mouth Rear	0.10-0.40mm (.004-.016")					
6. Bell Mouth Front	Not Applicable					
7. Conductor Brush	0.10-0.60mm (.004-.024")					
8. Cut-Off Tab	0.10mm (.004") Max					
Conductor Crimp	Terminal Order No.	Wire Size	9. Crimp Height		10. Crimp Width (Ref)	
	201649	24 AWG	0.52-0.62mm	.020-.024 In.	1.00mm	.039 In.
		26 AWG	0.48-0.58mm	.019-.023 In.	1.00mm	.039 In.
		28 AWG	0.45-0.55mm	.018-.022 In.	1.00mm	.039 In.
Insulation Crimp	Terminal Order No.	Wire Size	11. Crimp Height (Ref)		12. Crimp Width (Ref)	
	201649	24 AWG	1.55mm	.061 In.	1.15mm	.045 In.
		26 AWG	1.50mm	.059 In.	1.15mm	.045 In.
		28 AWG	1.40mm	.055 In.	1.15mm	.045 In.
Pull Force	Terminal Order No.	Wire Size	Minimum Pull Force		To be measured with no influence from the insulation crimp.	
	201649	24 AWG	29.4 N	6.6 lb.		
		26 AWG	19.6 N	4.4 lb.		
		28 AWG	9.8 N	2.2 lb.		
13. Conductor Anvil Flash	0.05mm (.002")					
Conductor Punch Width	1.00mm (.039")					
Insulation Punch Width	1.10mm (.043")					

Tool Qualification Notes

1. Pull force should be measured with no influence from the insulation crimp.
2. The above specifications are guidelines to an optimum crimp.
3. Oiler (63801-7240) required to crimp terminals to improve tooling life and also to minimize the crimp extrusions. See 63800-4900 FineAdjust manual.

NOTES

1. Molex recommends that an extra perishable tooling kit be maintained at your facility.
2. Verify tooling alignment by hand cycling the press and applicator before crimping under power. Check that all screws are tight.
3. Slugs, terminals, dirt and oil should be kept clear of the work area.
4. Wear safety glasses at all times.
5. For recommended maintenance, refer to the FineAdjust manual.

WARNINGS

CAUTION: This applicator must be installed in a press with a standard shut height of 135.80mm (5.346"). Tooling damage could result at a lower setting.

CAUTION: To prevent injury, never operate this applicator without the guards supplied with the press or wire-processing machine in place. Reference the press or wire processing manufacturer's instruction manual.

CAUTION: Molex tooling crimp specifications are valid only when used with Molex terminals and tooling manufactured by Molex and sold by Molex or authorized distributors ("Molex Tooling"). When using tooling other than Molex Tooling with Molex-specific connector systems listed in our ATS documents, the Molex Tooling qualification does not apply, and the responsibility for full qualification of the connector system is that of the customer. Molex accepts no liability for connector performance or tooling support where tooling other than Molex Tooling is used or where Molex Tooling is modified.

PARTS LIST

FineAdjust Applicator 203702-0400				
Item	Order No.	Engineering No.	Description	Quantity
Perishable Tooling				
	203702-0470	203702-0470	Tool Kit (All "Y" Items)	REF
1	200216-1000	200216-1000	Conductor Punch	1 Y
2	200217-1002	200217-1002	Conductor Anvil	1 Y
3	200220-1100	200220-1100	Insulation Punch	1 Y
4	200221-1103	200221-1103	Insulation Anvil	1 Y
5	63443-0005	63443-0005	Cut-Off Plunger	1 Y
6	63443-0012	63443-0012	Front Plunger Retainer	1 Y
Other Components				
7	11-18-4083	60707-8	Feed Guide	1
8	11-24-1067	11-24-1067	Cut-Off Plunger Spring	1
9	63443-0009	63443-0009	Scrap Chute	1
10	63443-0024	63443-0024	Key	1
11	200213-7554	200213-7554	Anvil Mount	1
12	63443-2201	63443-2201	Coarse Spacer	1
13	63443-2806	63443-2806	Front Plunger Striker	1
14	63443-2906	63443-2906	Wire Hold Down Plunger	1
15	63600-0021	63600-0021	Wire Hold Down Spring	1
16	63443-6110	63443-6110	Rear Cover	1
17	63443-7315	63443-7315	Terminal Hold Down Plunger	1
18	63700-0992	63700-0992	Terminal Hold Down Plunger Spring	1
19	63443-7324	63443-7324	Terminal Hold Down	1
20	63443-7335	63443-7335	Terminal Hold Down Retainer	1
21	63443-7317	63443-7317	Terminal Hold Down Retainer Plate	1
22	63443-7406	63443-7406	Terminal Hold Down Mount	1
Frame				
23	63800-4901	63800-4901	Top	1
24	63801-3281	63801-3281	Base	1
25	63801-4650	63801-4650	Track	1
Hardware				
26	—	—	M3 by 6 Long SHCS	3*
27	—	—	M3 by 6 Long FHCS	1*
28	—	—	M3 by 12 Long SHCS	1*
29	—	—	M3 Hex Nut	1*
30	—	—	M4 by 6 Long SHCS	1*
31	—	—	M4 by 10 Long SHCS	1*
32	—	—	M4 by 12 Long BHCS	2*
33	—	—	M4 by 45 Long SHCS	2*
34	—	—	#10-32 by 3/8" Long Flat Point SSS	1*
35	—	—	#10-32 Hex Jam Nut	1*

* Available from an industrial supply company.

ASSEMBLY DRAWING

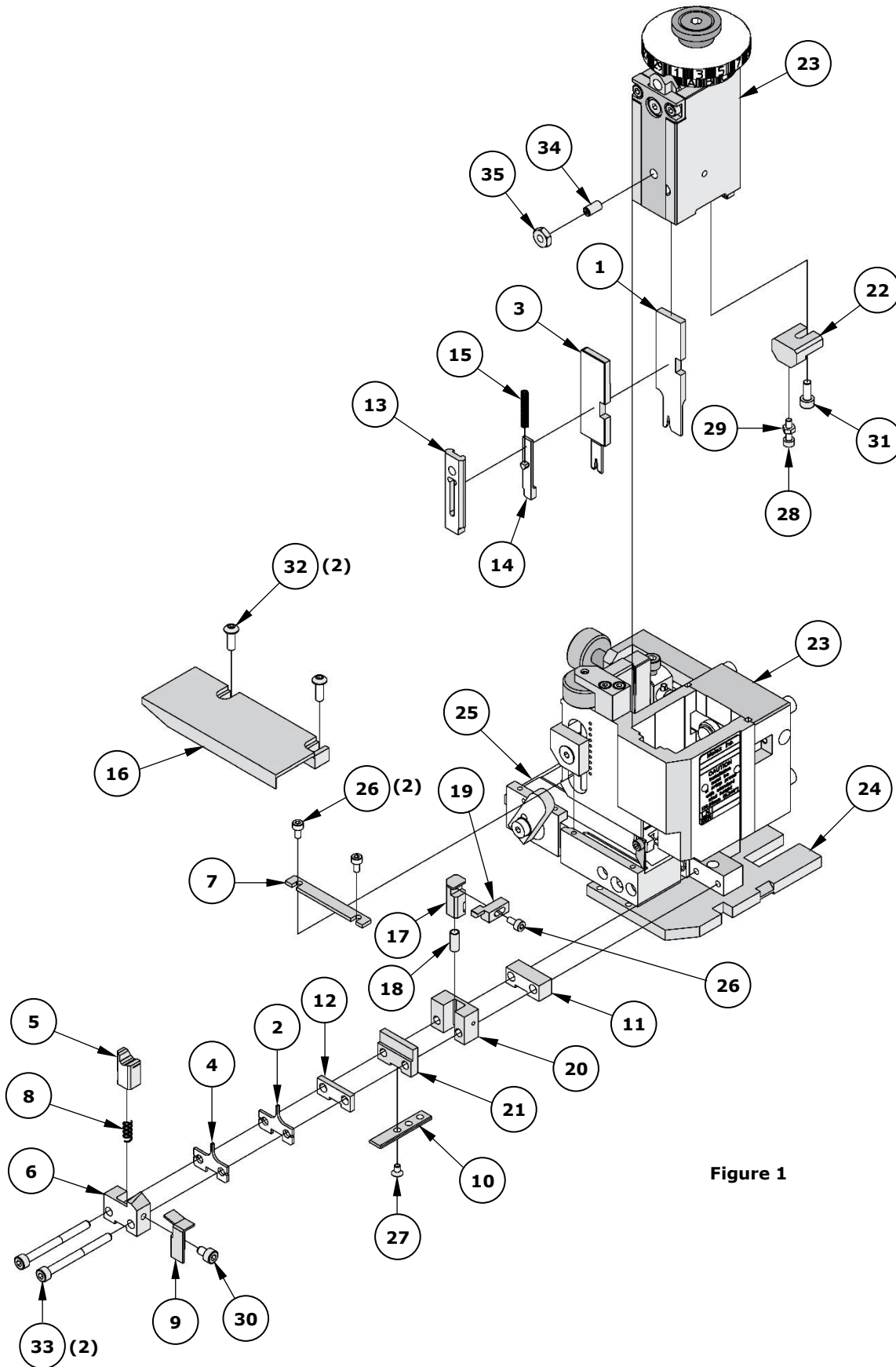

Figure 1

Application Tooling Support

Phone: (402) 458-TOOL (8665)

E-Mail: applicationtooling@molex.com

Website: www.molex.com/applicationtooling

Molex is a registered trademark of Molex, LLC in the United States of America and may be registered in other countries; all other trademarks listed herein belong to their respective owners.