

# TCC-82

## Port-powered RS-232 4-channel isolator

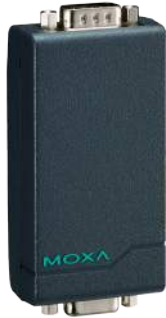

- > 4 channels of 4 kV RMS isolation for 1 minute
- > External power source supported but not required
- > 15 kV serial ESD protection
- > Automatic baudrate detection
- > Compact size



### Introduction

The TCC-82 provides full electrical isolation for bi-directional serial communication between two RS-232 devices in a compact, industrial-grade package. Both sides of an RS-232 connection are isolated optically to provide perfect protection against lightning surges, accidental high voltage shorts, and ground loops. The built-in, wide range isolators are tested to ensure that they can withstand more than 4 kV rms input to output for 1 minute. This means that the TCC-82 not only meets the requirements of general serial data communications, but also the high standards required by industrial automation and medical applications. The TCC-82 protects the Tx/D and Rx/D data lines, and also protects the RTS and CTS handshake lines for a total of 4 isolated channels to provide complete protection of your RS-232 applications.

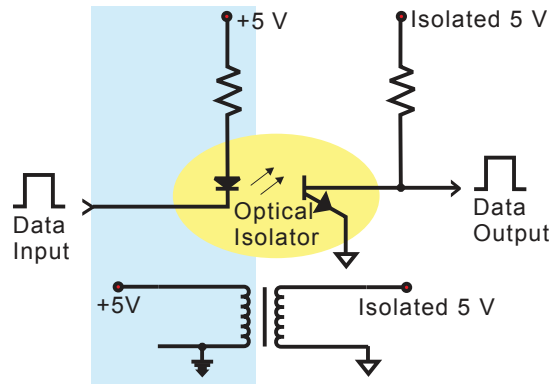

### External Power Source Not Required

The TCC-82 supports port-powered operation, which means that it can obtain power directly from the attached serial devices. Power is obtained from the RS-232 Tx/D, RTS, or DTR lines, regardless of whether the signal is high or low, eliminating the need for an external power supply. However, external power can be used if handshake lines are not available, if the serial cable is too long, or if the serial device is a low powered device. For external power, the TCC-82 can use a 5 to 12 VDC adaptor or a USB power cord. Note that both sides of the connection are powered independently, so if necessary, one side can rely on port power and the other on an external power source.

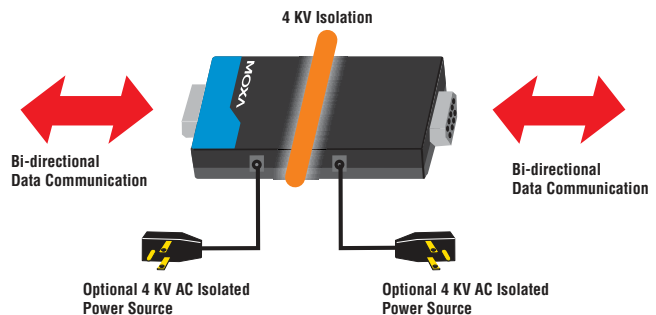

When installing the TCC-82, we recommend that you connect all output signals. The TCC-82 obtains power from these signals even if they are not used by your system. Care should be taken when choosing the external power supply if your application requires the full 4 kV of isolation. Most commercial power supplies provide only 1500 VAC isolation between the primary and secondary windings. If you are using external power for both sides of the TCC-82, make sure that separate power sources are used, each with sufficient isolation protection.

## Specifications

### Serial Communication

**Baudrate:** 50 bps to 921.6 kbps  
**ESD Protection:** 15 kV for all signals  
**Optical Isolation:** 4 kV for 1 minute

### Serial Interface

**Serial Standards:**  
 RS-232: TxD, RxD, RTS, CTS, GND  
 (Loop-back wiring: DTR to DSR and DCD)  
**Connector:** DB9 male and DB9 female

### Physical Characteristics

**Housing:** ABS  
**Dimensions:** 42 x 80 x 23.6 mm (1.65 x 3.15 x 0.93 in)  
**Weight:** 60 ± 5 g

### Environmental Limits

**Operating Temperature:** 0 to 60°C (32 to 140°F)  
**Storage Temperature:** -20 to 75°C (-4 to 167°F)  
**Ambient Relative Humidity:** 5 to 95% (non-condensing)

### Power Requirements

**Source of Input Power:** RS-232 port (TxD, RTS, DTR) or power input jack  
**Input Voltage:** 5 to 12 VDC  
**Power Consumption:** 20 mA @ 5 V

### Standards and Certifications

**Safety:** UL 60950-1  
**EMC:** CE, FCC  
**EMI:** FCC Part 15 Subpart B Class B  
**EMS:**  
 EN 61000-4-2 (ESD) Level 2,  
 EN 61000-4-3 (RS) Level 2,  
 EN 61000-4-4 (EFT) Level 2,  
 EN 61000-4-5 (Surge) Level 2,  
 EN 61000-4-6 (CS) Level 2,  
 EN 61000-4-8 (SFMF) Level 1  
**Green Product:** RoHS, CRoHS, WEEE  
**MTBF (mean time between failures):**  
**Time:** 959,780 hrs  
**Database:** MIL-HDBK-217F  
**Warranty**  
**Warranty Period:** 5 years  
**Details:** See [www.moxa.com/warranty](http://www.moxa.com/warranty)

## Dimensions

Unit: mm (inch)

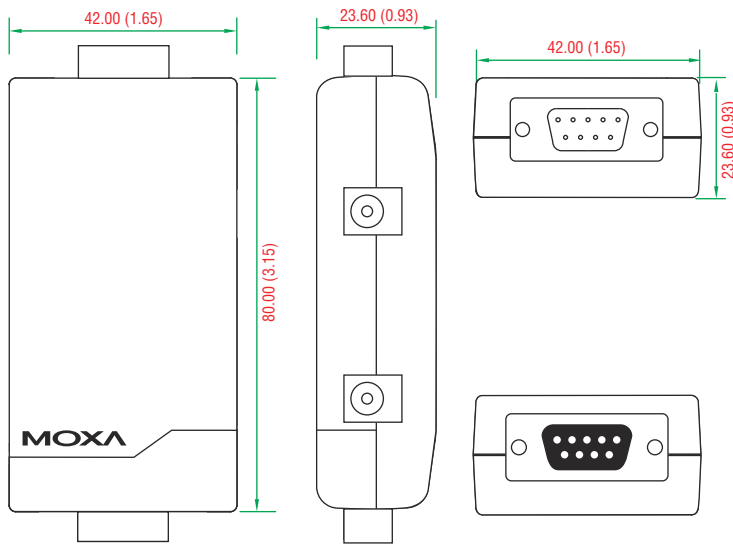

### DB9 female connector

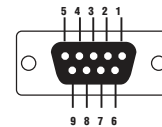

PIN	RS-232
1	DCD
2	TxD
3	RxD
4	DSR
5	GND
6	DTR
7	CTS
8	RTS

### DB9 male connector

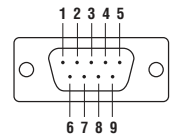

PIN	RS-232
1	DCD
2	RxD
3	TxD
4	DTR
5	GND
6	DSR
7	RTS
8	CTS

## Ordering Information

### Available Models

**TCC-82:** Port-powered RS-232 isolator with 4 kV isolation and 15 kV serial ESD protection

**Optional Accessories** (can be purchased separately)

**Power Adaptor:** See Appendix A for details

**CBL-F9M9-20:** DB9 male to DB9 female RS-232 cable (20 cm)

### Package Checklist

- 1 TCC-82 RS-232 isolator
- USB power cord (50 cm) x 2
- Quick installation guide (printed)
- Warranty card