

DATE	REV	ECN	APP'D. BY
1-7-15	A5	10173	TRM
3-16-16	A6	10620	TRM
9-12-22	A7	12040	TRM

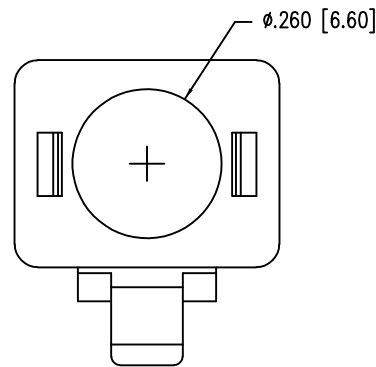
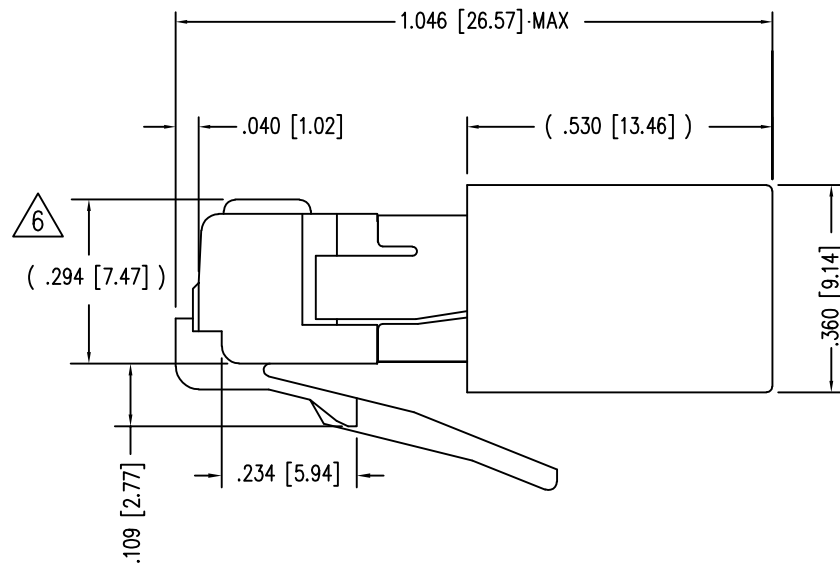
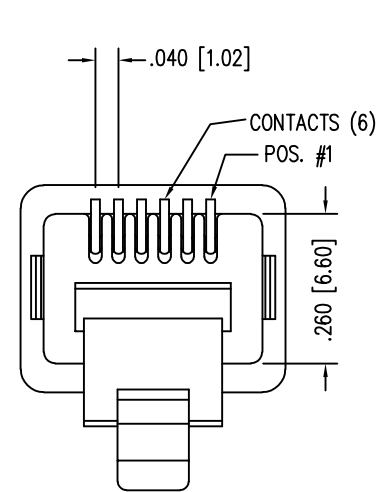
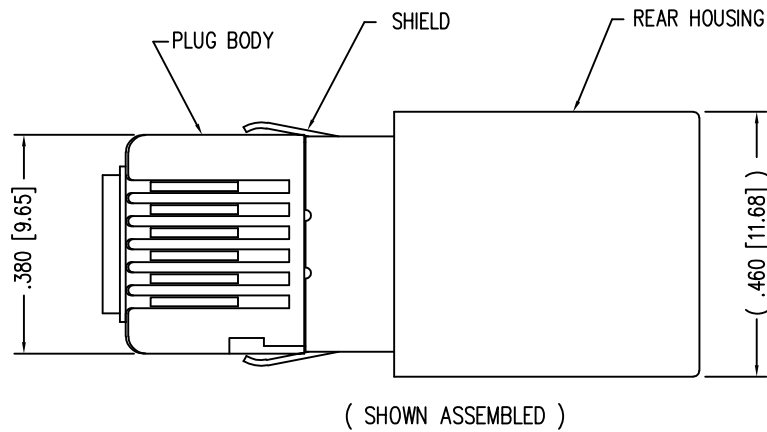

NOTES:

- 1- PLUG KIT CONSISTS OF :
PRE-INSERTED PLUG HOUSING & SHIELD
LOAD BAR
FERRULE
- 2- MATERIALS :
FRONT HOUSING PLASTIC : CLEAR POLYCARBONATE, UL 94-V0
LOAD BAR : POLYCARBONATE, BLUE, UL 94-V0
SHIELD : TIN PLATED BRASS
CONTACTS : PHOSPHOR BRONZE, SELECTIVE GOLD PLATING
FERRULE : NICKEL OR TIN PLATED BRASS
- 3- CONTACTS TERMINATE STRANDED CONDUCTORS UP TO .031 [0.79] OUTSIDE DIAMETER OF INSULATION.
- 4- FOR PLUG SPECIFICATION SEE PR026-01.
- 5- DIMENSIONS & TOLERANCES COMPLY WITH TIA-1096 STANDARD
- △ TERMINATED PLUG HEIGHT: .237 [6.02] ±.005 [0.13] ON CABLE

BULK	50 MICRO-INCHES [1.27um]	940-SP-360606-A152
PACKAGE	CONTACT PLATING IN MATING AREA	PART NUMBER

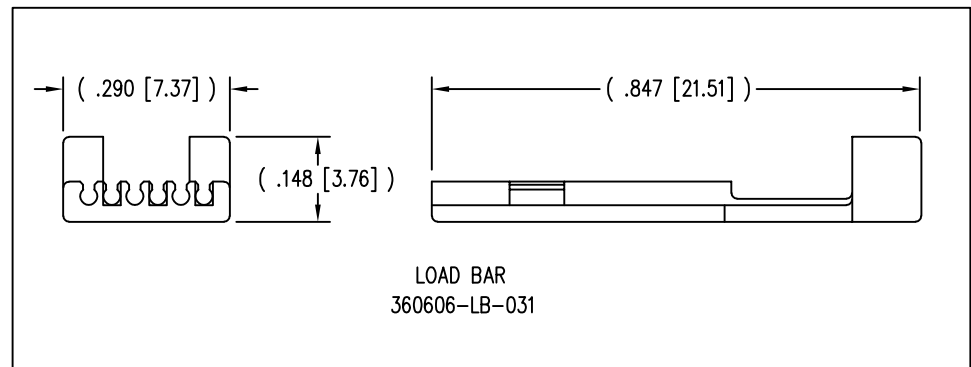
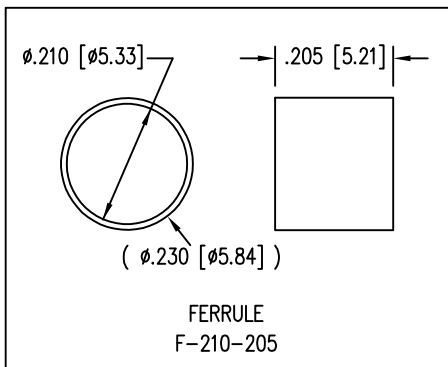

THIRD ANGLE PROJECTION

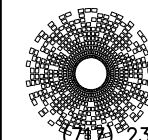
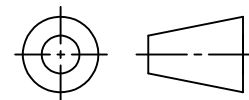

stewart
CONNECTOR

11118 Susquehanna Trail South
Glen Rock, PA 17327-9199
(717) 235-7512

<http://www.stewartconnector.com>

DO NOT SCALE DRAWING
DRAWING IS SUBJECT TO
CHANGE WITHOUT NOTICE

TITLE: 6 x 6 SHIELDED PLUG

DIMENSIONS: INCHES [METRIC]
UNLESS OTHERWISE SPECIFIED
TOLERANCES ARE ±.005 [0.13]
ANGLES ARE ± 1°

THIS DRAWING AND THE SUBJECT MATTER SHOWN THEREON ARE CONFIDENTIAL AND THE PROPRIETARY PROPERTY OF STEWART CONNECTOR AND SHALL NOT BE REPRODUCED, COPIED, OR USED IN ANY MANNER WITHOUT PRIOR WRITTEN CONSENT OF STEWART CONNECTOR. ONE OR MORE U.S. PATENTS MAY APPLY TO THIS PRODUCT. FOR DETAILS, PLEASE VISIT: [HTTP://BELFUSE.COM/STEWART/STEWART_PATENTS/](http://BELFUSE.COM/STEWART/STEWART_PATENTS/)

DRN BY:	TRM	DATE	8-28-00
APPD BY:	RGC	DATE	8-28-00
DWG NO.	CT360148	REV.	A7

SHEET NO. 1 OF 1