

DO NOT SCALE FROM THIS PRINT

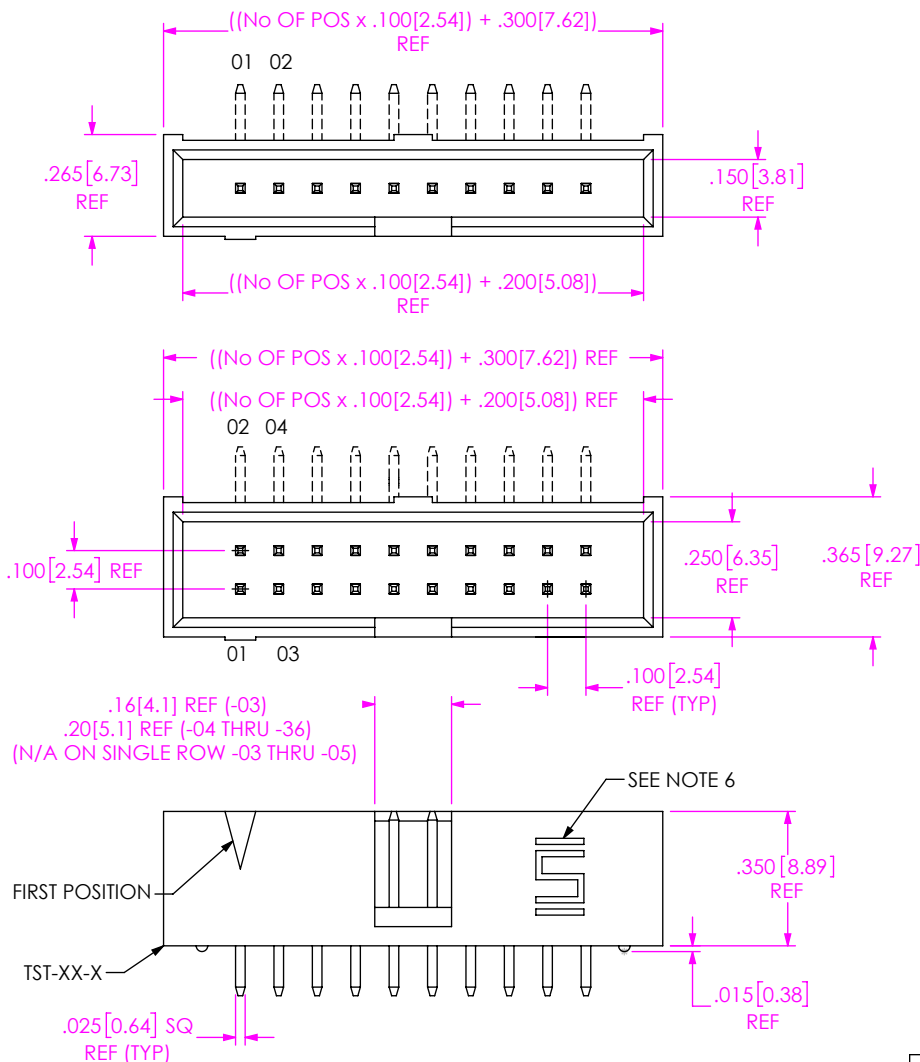

TST-1XX-XX-X-X-XX-XX

**NO OF POSITIONS**  
 -02 (STRAIGHT ONLY)  
 -03 THRU -18, -20, -24,  
 -25, -28, -30, -32 & -36

**LEAD STYLE**  
 SEE TABLE 1

**POLARIZE OPTION**  
 -XX INDICATES POSITION OMITTED

**OPTION**  
 BLANK: STRAIGHT (STYLES -04 & -05 N/A)  
 (SEE NOTE 5)  
 -RA: RIGHT ANGLE (STYLES -01, -02 & -03 N/A)  
 -LL: LOCKING LEAD  
 -LA: -RA OPTION WITH -LL OPTION

**ROW SPECIFICATION**  
 -D: DOUBLE  
 -S: SINGLE

**PLATING SPECIFICATION**  
 -G: GOLD, 10 Au / 50 Ni ON CONTACT,  
 3 Au / 50 Ni ON TAIL  
 -T: MATTE TIN, CONTACT AND TAIL  
 -S: SELECTIVE, 30 Au / 50 Ni MIN ON CONTACT,  
 MATTE TIN TAIL  
 -L: LIGHT SELECTIVE, 10 Au / 50 Ni MIN ON CONTACT,  
 MATTE TIN TAIL  
 -H: HEAVY GOLD, 30 Au / 50 Ni MIN ON CONTACT,  
 3 Au / 50 Ni ON TAIL  
 -F: FLASH SELECTIVE, 3 Au / 50 Ni ON CONTACT,  
 MATTE TIN TAIL

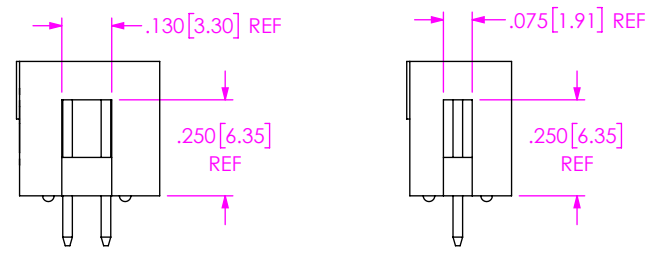

**TABLE 1**

LEAD STYLE	"A"	"B"	"C"	"D"	TERMINAL 1	TERMINAL 2
-01	.480 [12.19]	----	----	----	T-1S6-17-X-2	-----
-02	.530 [13.46]	----	----	----	T-1S6-08-X-2	-----
-03	.930 [23.62]	----	----	----	T-1S6-11-X-2	-----
-04	----	.130 [3.30]	.280 [7.11]	.830 [21.08]	T-1S6-15-X-2	T-1S6-10-X-2
-05	----	.230 [5.84]	.380 [9.65]	.930 [23.62]	T-1S6-09-X-2	T-1S6-11-X-2

NOTES:

- REPRESENTS A CRITICAL DIMENSION
- TERMINAL PUSHOUT FORCE: 3 LB
- ASSEMBLE GOLD PLATED END AS SHOWN.
- TERMINALS TO BE FLUSH TO .010[0.25] BELOW TOP OF SHROUD.
- TST-1XX-04-X-D-RA-XX ASSEMBLIES ARE TO BE PACKAGED IN A PT-1-24-01-40, TUBE WITH TWO TP-13 PLUGS PER TUBE(ALL POSITIONS).
- SAMTEC LOGO MAY VARY IN LOCATION.
- TST-1XX-05-X-D-RA-XX ASSEMBLIES ARE TO BE PACKAGED IN PT-1-24-12T-109 USING TP-28

UNLESS OTHERWISE SPECIFIED, DIMENSIONS ARE IN INCHES.

TOLERANCES ARE:  
 DECIMALS ANGLES  
 .XX: ±.01[0.3] 2°  
 .XXX: ±.005[0.13]  
 .XXXX: ±.0020[0.051]

**PROPRIETARY NOTE**  
 THIS DOCUMENT CONTAINS CONFIDENTIAL AND PROPRIETARY INFORMATION AND ALL DESIGN, MANUFACTURING, REPRODUCTION, USE, PATENT RIGHTS AND SALES RIGHTS ARE EXPRESSLY RESERVED BY SAMTEC, INC. THIS DOCUMENT SHALL NOT BE DISCLOSED, IN WHOLE OR PART, TO ANY UNAUTHORIZED PERSON OR ENTITY NOR REPRODUCED, TRANSFERRED OR INCORPORATED IN ANY OTHER PROJECT IN ANY MANNER WITHOUT THE EXPRESS WRITTEN CONSENT OF SAMTEC, INC.



520 PARK EAST BLVD, NEW ALBANY, IN 47150  
 PHONE: 812-944-6733 FAX: 812-948-5047  
 e-Mail: info@SAMTEC.com code: 55322

MATERIAL: DO NOT SCALE DRAWING SHEET SCALE: 2:1  
 INSULATOR: VALOX SE0 OR 553, OR CELANEX 3316  
 COLOR: BLACK  
 TERMINAL: PHOS BRONZE, ALLOY No 10, GRADE A, FEDERAL SPEC. QQ-B-750, 3/4 HARD, 95-105 KPSI TENSILE.  
 MATERIAL THICKNESS: .0250±.0003[0.635±.0076]  
 F:\DWG\MISC\MKTG\TST-1XX-XX-X-X-XX-MKT.SLDDRW

DESCRIPTION:  
 TOP SHROUD TERMINAL STRIP  
 DWG. NO.  
**TST-1XX-XX-X-X-XX-XX**  
 BY: JORDAN 02/18/1987 SHEET 1 OF 3

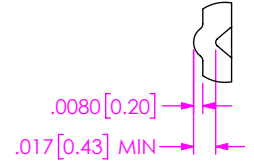
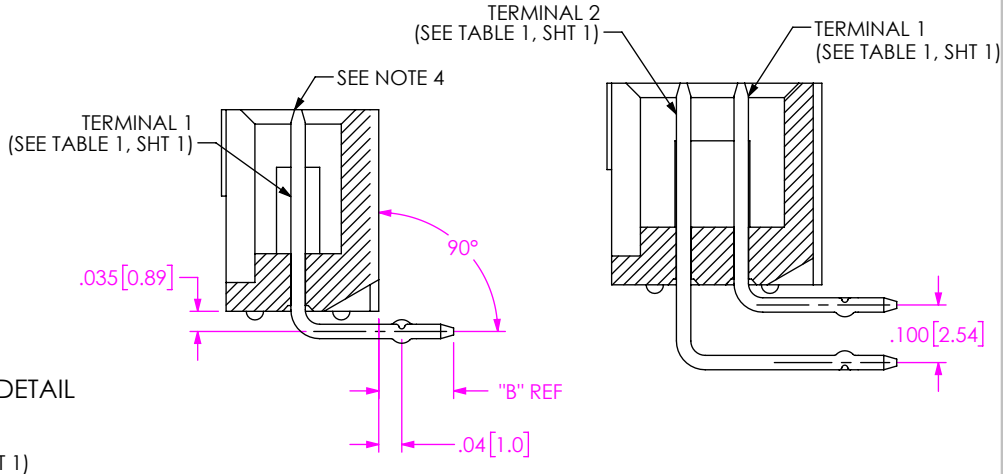
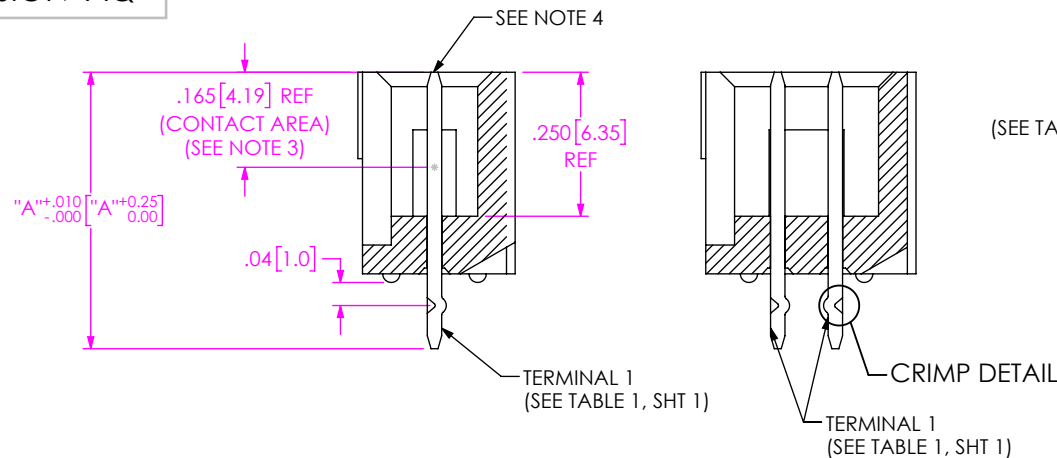

**-S**  
(-LL SHOWN FOR DIMENSIONAL AND LOCATION PURPOSES)

**-D**  
(SAME AS -S, EXCEPT AS SHOWN)

**-S-RA**  
(-LA SHOWN FOR DIMENSIONAL AND LOCATION PURPOSES)

**-D-RA**  
(SAME AS -S-RA, EXCEPT AS SHOWN)

**CRIMP DETAIL**  
SCALE 6 : 1

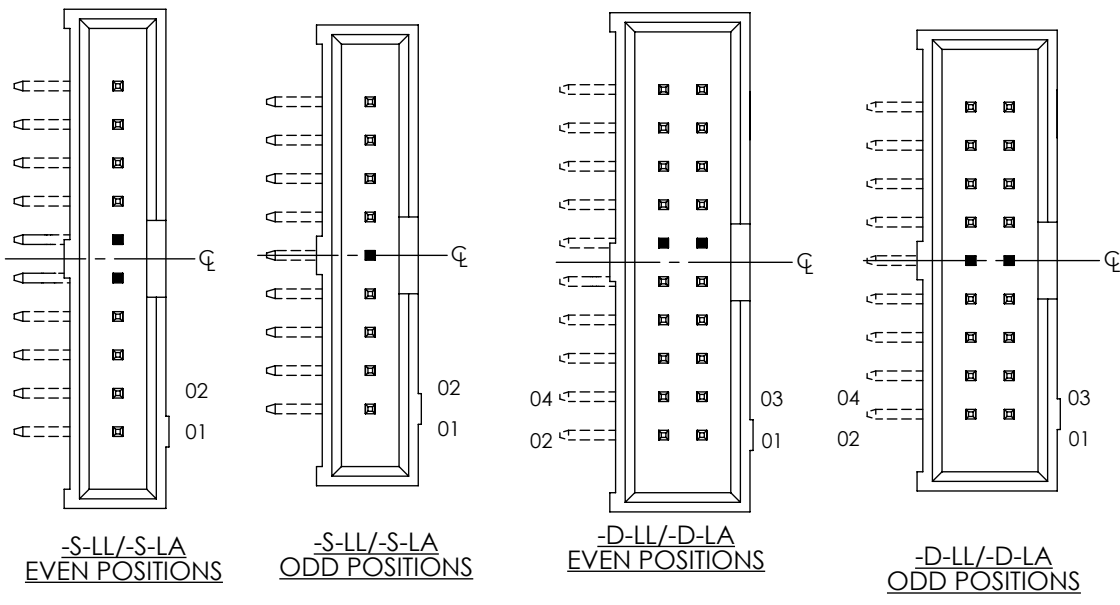
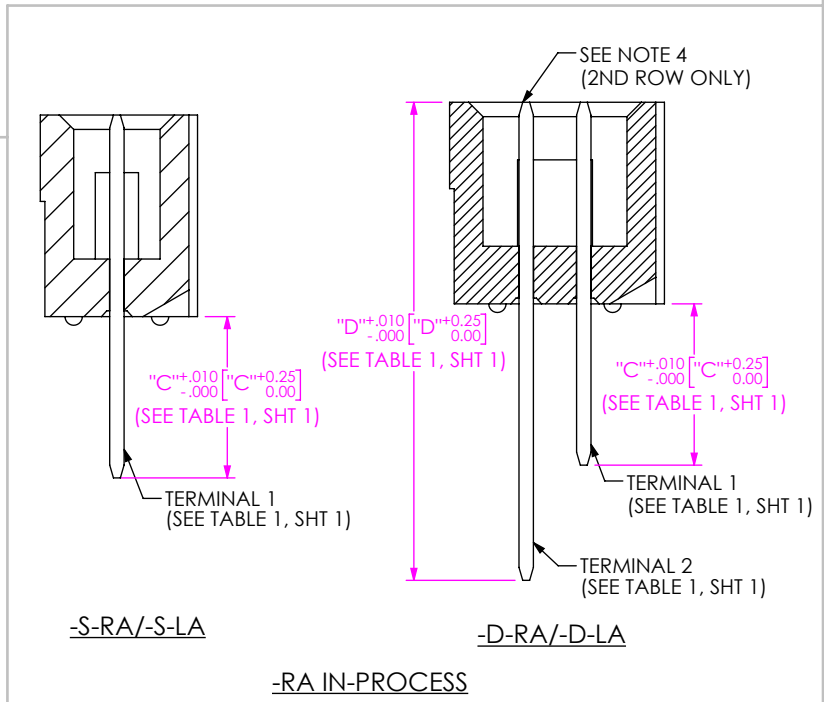

**CRIMP LOCATION**

**PROPRIETARY NOTE**  
THIS DOCUMENT CONTAINS CONFIDENTIAL AND PROPRIETARY INFORMATION AND ALL DESIGN, MANUFACTURING, REPRODUCTION, USE, PATENT RIGHTS AND SALES RIGHTS ARE EXPRESSLY RESERVED BY SAMTEC, INC. THIS DOCUMENT SHALL NOT BE DISCLOSED, IN WHOLE OR PART, TO ANY UNAUTHORIZED PERSON OR ENTITY NOR REPRODUCED, TRANSFERRED OR INCORPORATED IN ANY OTHER PROJECT IN ANY MANNER WITHOUT THE EXPRESS WRITTEN CONSENT OF SAMTEC, INC.



520 PARK EAST BLVD. NEW ALBANY, IN 47150  
PHONE: 812-944-6733 FAX: 812-948-5047  
e-Mail: info@SAMTEC.com code: 55322

SHEET SCALE: 3:1

DESCRIPTION:  
**TOP SHROUD TERMINAL STRIP**

DWG. NO.  
**TST-1XX-XX-X-X-XX-XX**

BY: JORDAN 02/18/1987 SHEET 2 OF 3

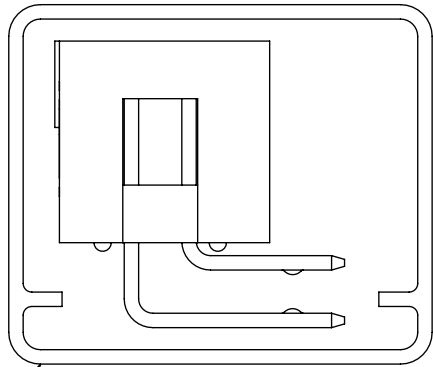

PT-1-24-12T-109

PACKAGING VIEW  
TST-1XX-05-X-D-RA-XX  
USE TP-28

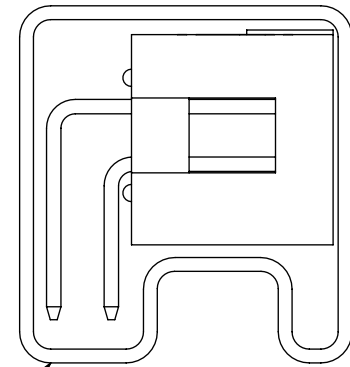

PT-1-24-01-40

PACKAGING VIEW  
TST-1XX-04-X-D-RA-XX  
USE TP-13

**PROPRIETARY NOTE**  
THIS DOCUMENT CONTAINS CONFIDENTIAL AND PROPRIETARY INFORMATION AND ALL DESIGN, MANUFACTURING, REPRODUCTION, USE, PATENT RIGHTS AND SALES RIGHTS ARE EXPRESSLY RESERVED BY SAMTEC, INC. THIS DOCUMENT SHALL NOT BE DISCLOSED, IN WHOLE OR PART, TO ANY UNAUTHORIZED PERSON OR ENTITY NOR REPRODUCED, TRANSFERRED OR INCORPORATED IN ANY OTHER PROJECT IN ANY MANNER WITHOUT THE EXPRESS WRITTEN CONSENT OF SAMTEC, INC.



520 PARK EAST BLVD, NEW ALBANY, IN 47150  
PHONE: 812-944-6733 FAX: 812-948-5047  
e-Mail: info@SAMTEC.com code: 55322

SHEET SCALE: 3:1

DESCRIPTION:  
TOP SHROUD TERMINAL STRIP

DWG. NO.  
**TST-1XX-XX-X-X-XX-XX**

BY: JORDAN 02/18/1987 SHEET 3 OF 3