

LOC		DIST		REVISIONS			
GP	00	REV	DATE	BY	CHK	APPV	
G1	REVISED PER ECR-15-007038		28SEP2015	NK		PQ	

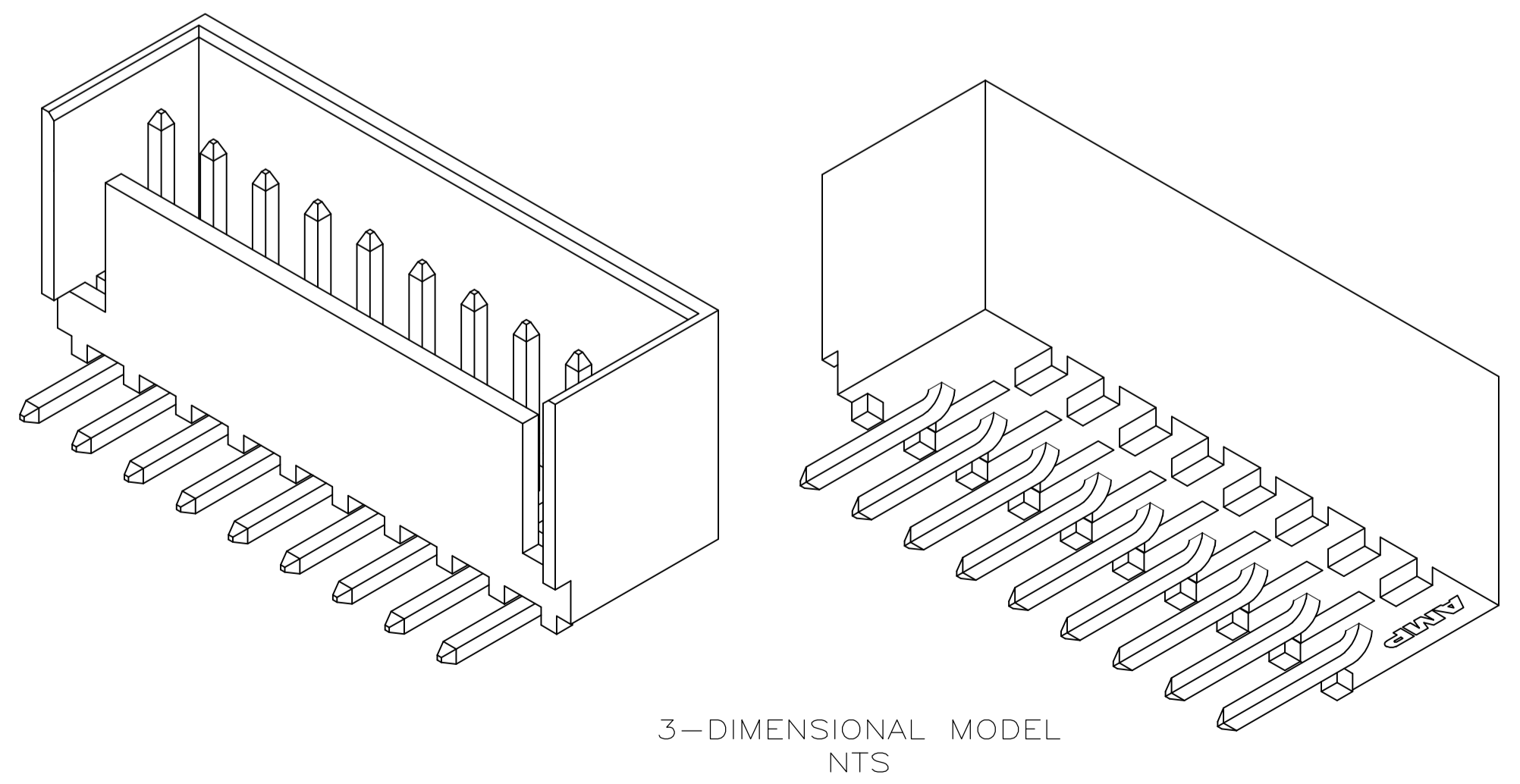

.025	0.64	.107	2.72	-	-
.010	0.25	.100	2.54	.410	10.41
.005	0.13	.092	2.34	.313	7.95
.001	0.03	.063	1.60	.300	7.62
.000350	0.00889	.040	1.02	.280	7.11
.000150	0.00381	.036	0.91	.176	4.47
.000050	0.00127	.035	0.89	.165	4.19
.000030	0.00076	.032	0.81	.140	3.56
.000	0.00	.030	0.76	.130	3.30
IN	MM	IN	MM	IN	MM

CONVERSION TABLE

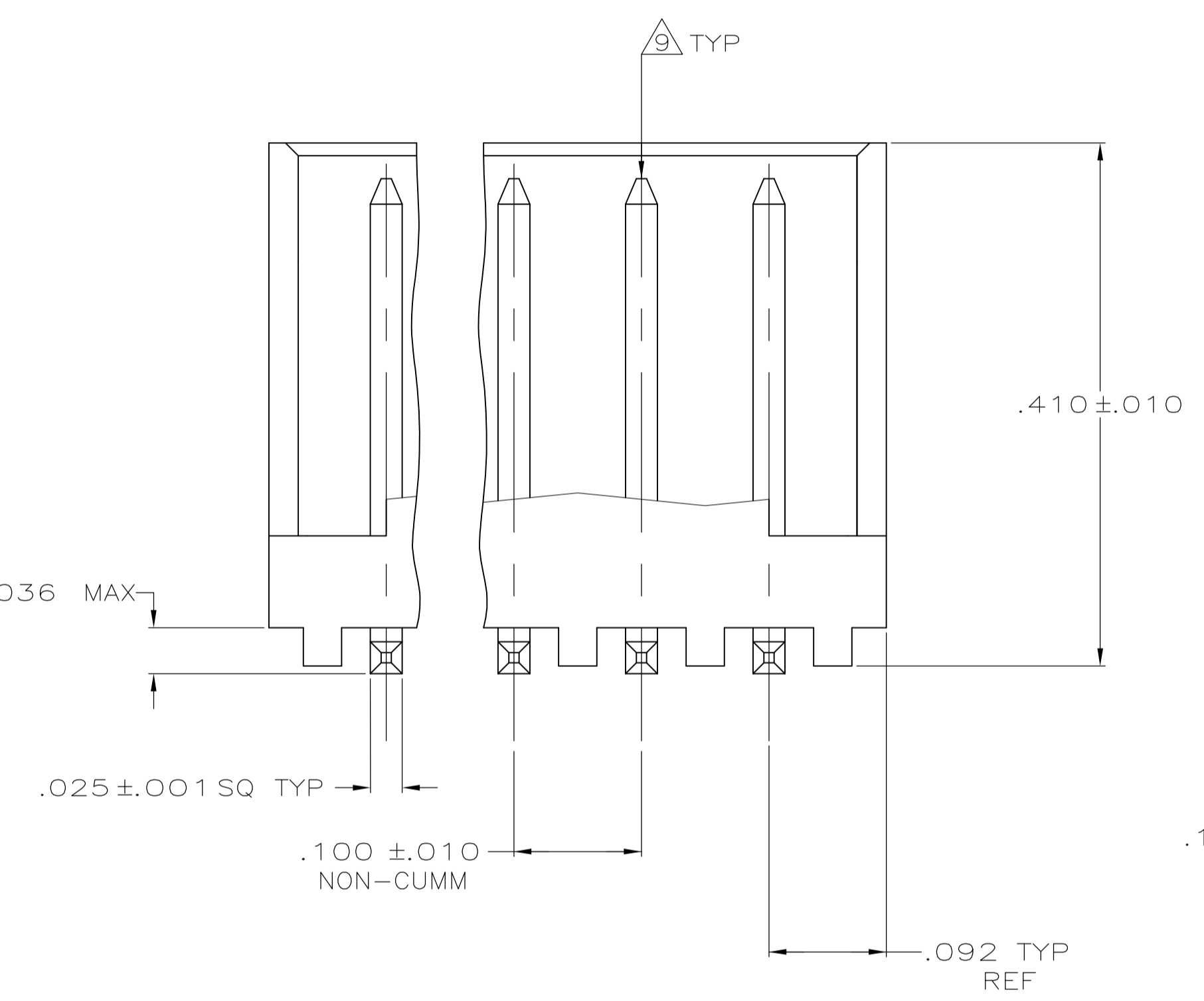
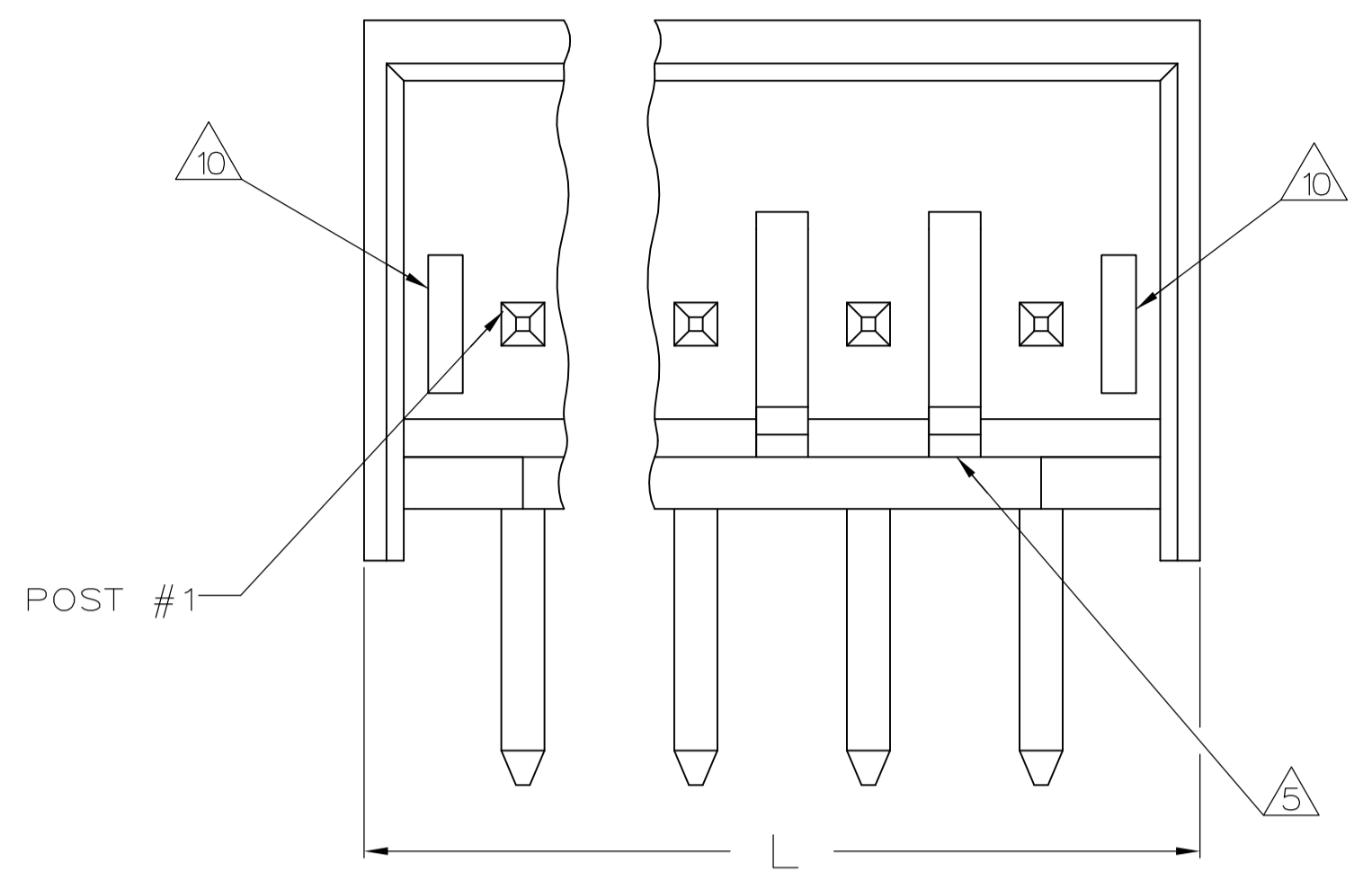
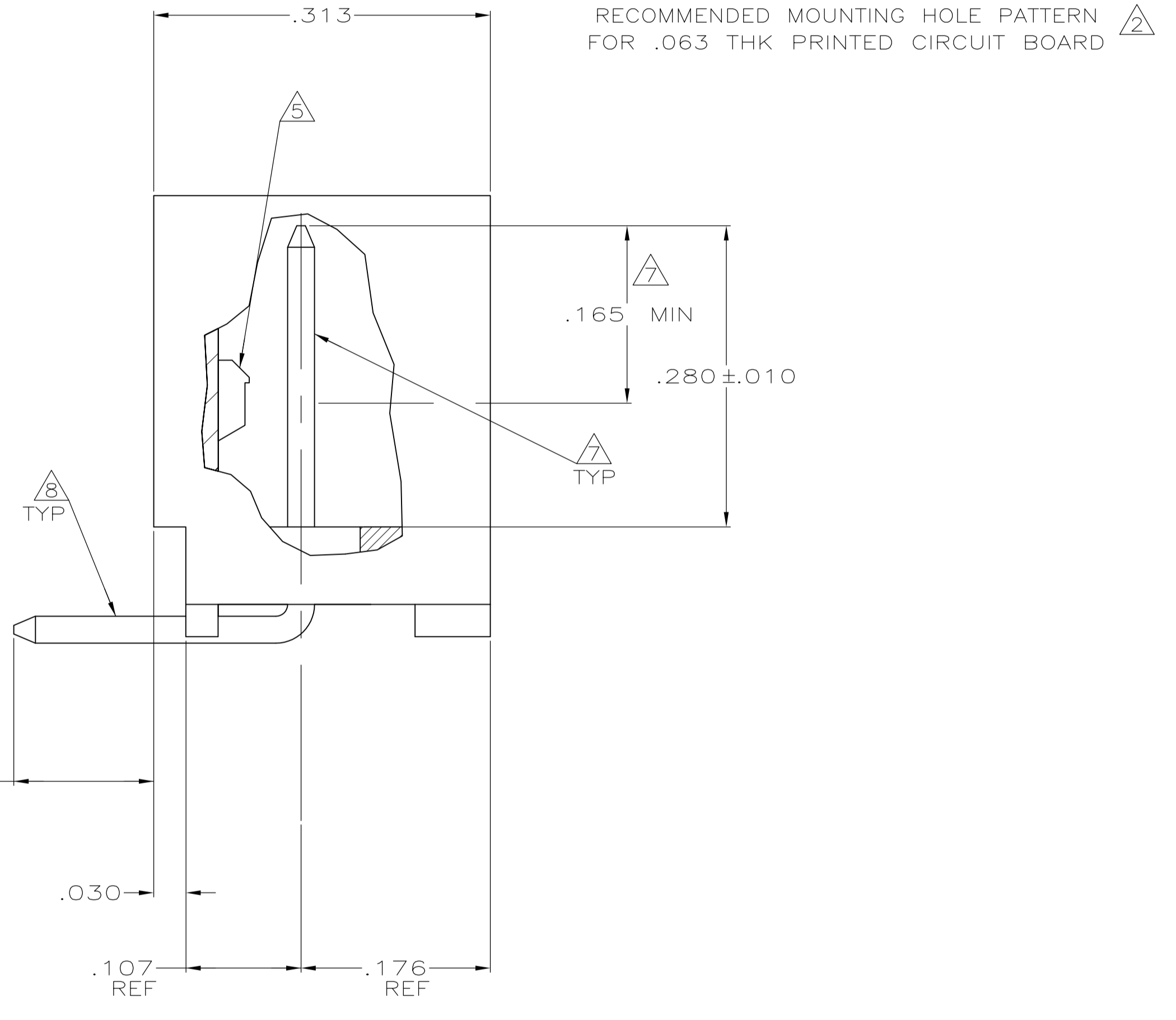
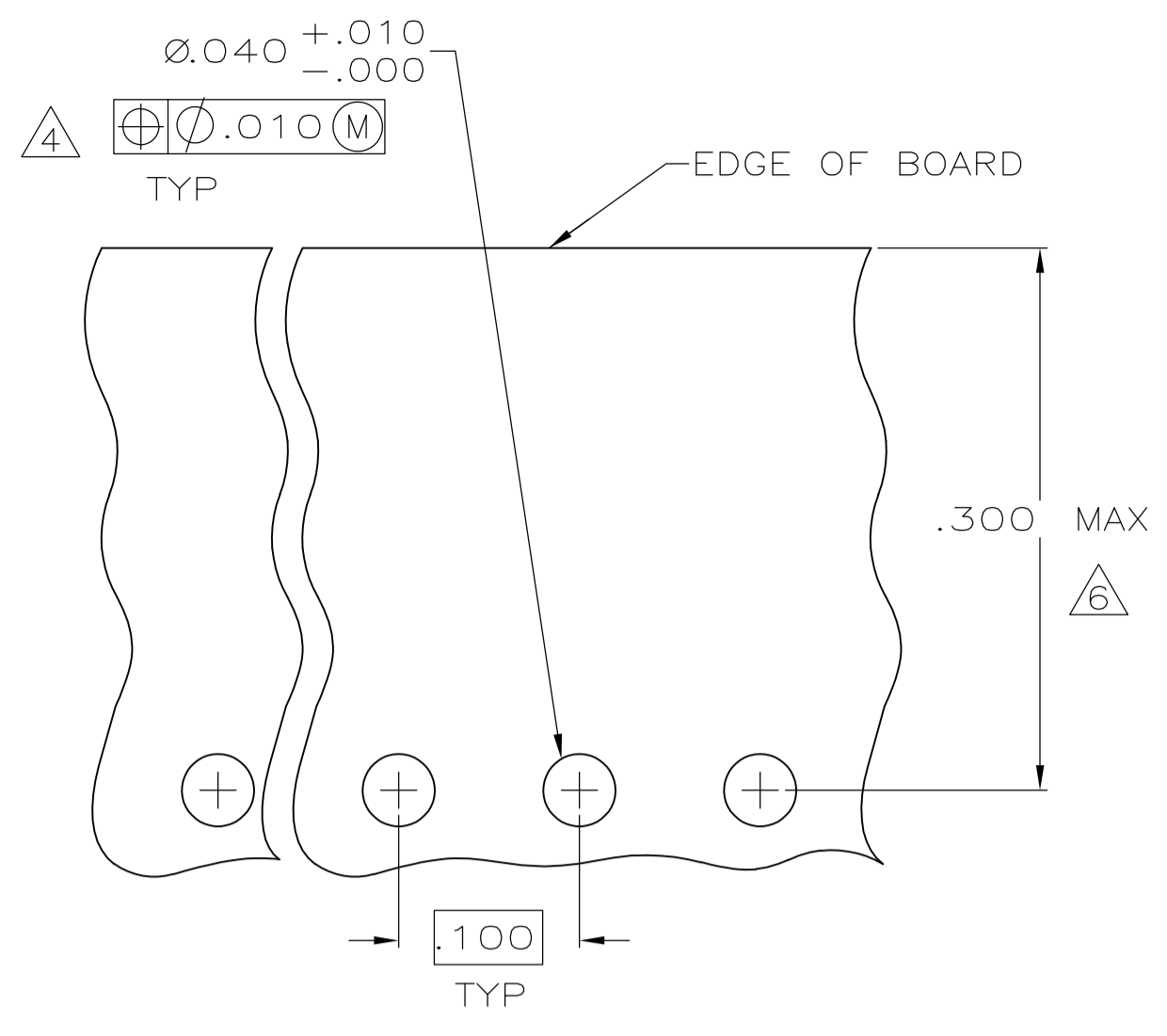

- 1 MATERIAL: HEADER - POLYESTER UL94V-0 (BLACK)  
POST - COPPER ALLOY.
- 2 SOLDER SIDE OF P.C. BOARD SHOWN.
- 3 PARTS COMPLY WITH TYCO ELECTRONICS SOLDERABILITY SPEC 109-11-12 (TIN).
- 4 ONE HOLE MAY BE UNDERSIZED (.032-.035 DIA) FOR ASSEMBLY RETENTION DURING WAVE SOLDERING.
- 5 LATCH DETENT FEATURE OCCURS 2 PLACES ON EACH END (MAXIMUM OF FOUR PER PART). FOR 2 THRU 5 CIRCUIT HEADERS, LATCH FEATURE OCCURS BETWEEN EACH CIRCUIT.
- 6 COORDINATE DIMENSION APPLIES FROM CENTER OF ACTUAL FEATURE.
- 7 GOLD PLATE, .000030 MIN, FOUR SIDES AS SHOWN, OVER NICKEL UNDERPLATE, .000050 MIN, ALL SIDES AND ENTIRE LENGTH OF POST.  
OR  
GOLD FLASH OVER PALLADIUM-NICKEL, .000030 MIN TOTAL THICKNESS AS SHOWN, OVER NICKEL UNDERPLATE .000050 MIN ALL SIDES AND ENTIRE LENGTH OF POST. EITHER PLATING MAY BE PROVIDED AT THE DISCRETION OF TYCO ELECTRONICS.
- 8 TIN PLATE, ALL FOUR SIDES, .140 REF.
- 9 POST MUST WITHSTAND 3.0 LBS (13.34 NEWTONS) MIN FORCE WITHOUT DISLODGING, EITHER DIRECTION.
- 10 SLOTS MAY OR MAY NOT APPEAR ON THESE PARTS.
- 11 MATTE TIN (100%) PLATE, ALL FOUR SIDES, .140 REF.
- 12 UL RECOGNIZED ( UR ) LOGO AND CSA LOGO WILL APPEAR ON THE SIDE OF THE PART, AMP LOGO MAY APPEAR ON THE SIDE OF THE PART OR ON THE BOTTOM.
- 13 OBSOLETE PART NUMBER

1.484	37.69	14	4-644898-4
1.384	35.15	13	4-644898-3
1.284	32.61	12	4-644898-2
1.184	30.07	11	4-644898-1
1.084	27.53	10	4-644898-0
.984	24.99	9	3-644898-9
.884	22.45	8	3-644898-8
.784	19.91	7	3-644898-7
.684	17.37	6	3-644898-6
.584	14.83	5	3-644898-5
.484	12.29	4	3-644898-4
.384	9.75	3	3-644898-3
.284	7.21	2	3-644898-2
1.484	37.69	14	13-644898-4
1.384	35.15	13	13-644898-3
1.284	32.61	12	13-644898-2
1.184	30.07	11	13-644898-1
1.084	27.53	10	13-644898-0
.984	24.99	9	13-644898-9
.884	22.45	8	13-644898-8
.784	19.91	7	13-644898-7
.684	17.37	6	13-644898-6
.584	14.83	5	13-644898-5
.484	12.29	4	13-644898-4
.384	9.75	3	13-644898-3
.284	7.21	2	13-644898-2
IN	MM	NO OF POSITIONS	PART NUMBER
L			HEADER ASSEMBLY

THIS DRAWING IS A CONTROLLED DOCUMENT.

DIN K. WHITAKER 27JUNE2005  
CHK D. ROSSI 27JUNE2005  
APPV D. ROSSI 27JUNE2005

TE Connectivity

CST-100 SHROUDED HEADER ASSEMBLY, FRICTION LOCK, RIGHT ANGLE POST, .000030 GOLD

SIZE: A1 CASE CODE: 00779 DRAWING NO: 644898

RESTRICTED TO: CUSTOMER DRAWING

SCALE: 10:1 SHEET: 1 OF 1 REV: G1