

ECN/PCN No.: 4146

For Manufacturer			
Product Description: PLASTIC SMD MEMS OSCILLATOR	Abracon Part Number / Part Series: EMRB63	<input type="checkbox"/> Documentation only <input type="checkbox"/> ECN <input checked="" type="checkbox"/> EOL	<input checked="" type="checkbox"/> Series <input type="checkbox"/> Part Number
Affected Revision: B	New Revision: EOL	Application:	<input type="checkbox"/> Safety <input checked="" type="checkbox"/> Non-Safety
Prior to Change: Active https://abracon.com/datasheets/Ecliptek/EMRB63.pdf			
After Change: EOL			
Cause/Reason for Change: Discontinuation of manufacturing capability.			
Change Plan			
Effective Date: 2/7/2022	Additional Remarks: N/A		
Change Declaration: N/A			
Issued Date: 2/7/2022	Issued By: <i>Brooke Cushman Product Engineer</i>	Issued Department: Engineering	
Approval: <i>Thomas Culhane Engineering Director</i>	Approval: <i>Reuben Quintanilla Quality Director</i>	Approval: <i>Ying Huang Purchasing Director</i>	
For Abracon EOL only			
Last Time Buy (if applicable): 5/7/2022	Alternate Part Number / Part Series: none		
Additional Approval:	Additional Approval:	Additional Approval:	
Customer Approval (If Applicable)			
Qualification Status: <input type="checkbox"/> Approved <input type="checkbox"/> Not accepted <i>Note: It is considered approved if there is no feedback from the customer 1 month after ECN/PCN is released.</i>			
Customer Part Number:		Customer Project:	
Company Name:	Company Representative:	Representative Signature:	
Customer Remarks:			

REGULATORY COMPLIANCE



ITEM DESCRIPTION

MEMS Clock Oscillators LVCMOS (CMOS) 3.3Vdc 4 Pad 1.2mm x 2.0mm Plastic Surface Mount (SMD)

ELECTRICAL SPECIFICATIONS

Nominal Frequency	32.768kHz
Frequency Tolerance/Stability	Inclusive of all conditions: Calibration Tolerance at 25°C, Frequency Stability over the Operating Temperature Range, Supply Voltage Change, and Output Load Change ±75ppm Maximum over -10°C to +70°C ±100ppm Maximum over -40°C to +85°C
Frequency Tolerance	Measured at 25°C ±2°C, at Vdd=3.3Vdc, Post Reflow ±20ppm Maximum
Aging at 25°C	±1ppm Maximum First Year
Supply Voltage	3.3Vdc ±10%
Input Current	No Load, Nominal Vdd 1.0µA Typical (at 25°C), 2.2µA Maximum at Frequency Tolerance/Stability of ±100ppm Maximum over -40°C to +85°C 1.0µA Typical (at 25°C), 1.9µA Maximum at Frequency Tolerance/Stability of ±75ppm Maximum over -10°C to +70°C
Output Voltage Logic High (V _{OH})	I _{OH} = -10µA 90% of Vdd Minimum
Output Voltage Logic Low (V _{OL})	I _{OL} = +10µA 10% of Vdd Maximum
Rise/Fall Time	Measured from 10% to 90% of waveform 100nSec Typical, 200nSec Maximum
Duty Cycle	Measured at 50% of waveform 50 ±2(%)
Load Drive Capability	15pF Maximum
Output Logic Type	CMOS
Period Jitter (RMS)	Measured at 25°C 35nSec Typical
Power Supply Ramp	Measured at 0Vdc to 90% of Vdd 100mSec Maximum
Start Up Time	Measured at Nominal Vdd 180mSec Typical, 500mSec Maximum at Frequency Tolerance/Stability of ±100ppm Maximum over -40°C to +85°C 180mSec Typical, 450mSec Maximum at Frequency Tolerance/Stability of ±75ppm Maximum over -10°C to +70°C
Storage Temperature Range	-55°C to +125°C

PART NUMBERING GUIDE

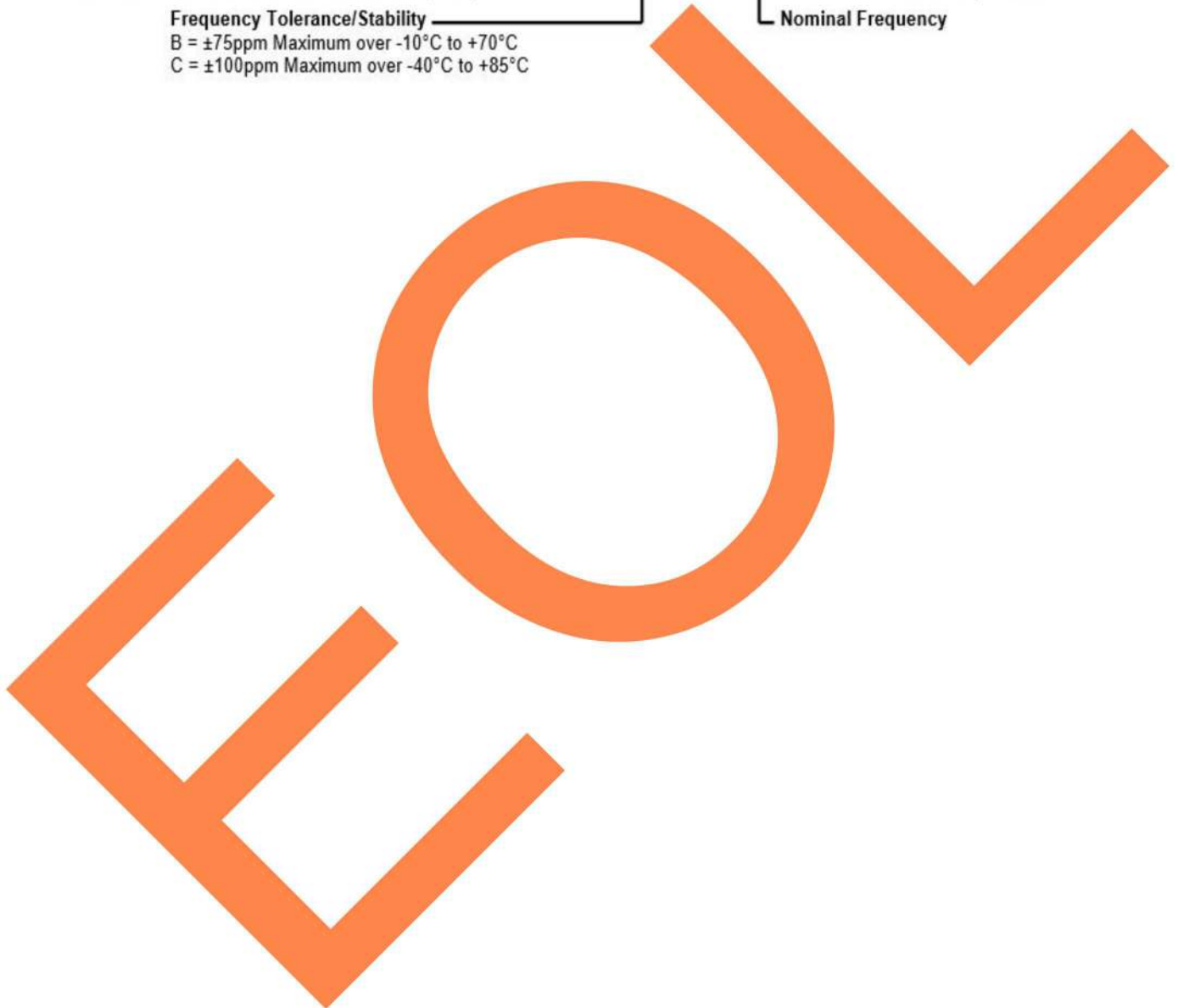
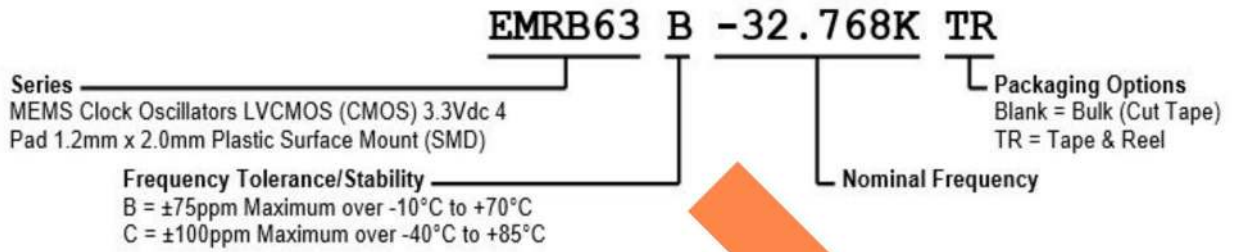

MECHANICAL DIMENSIONS

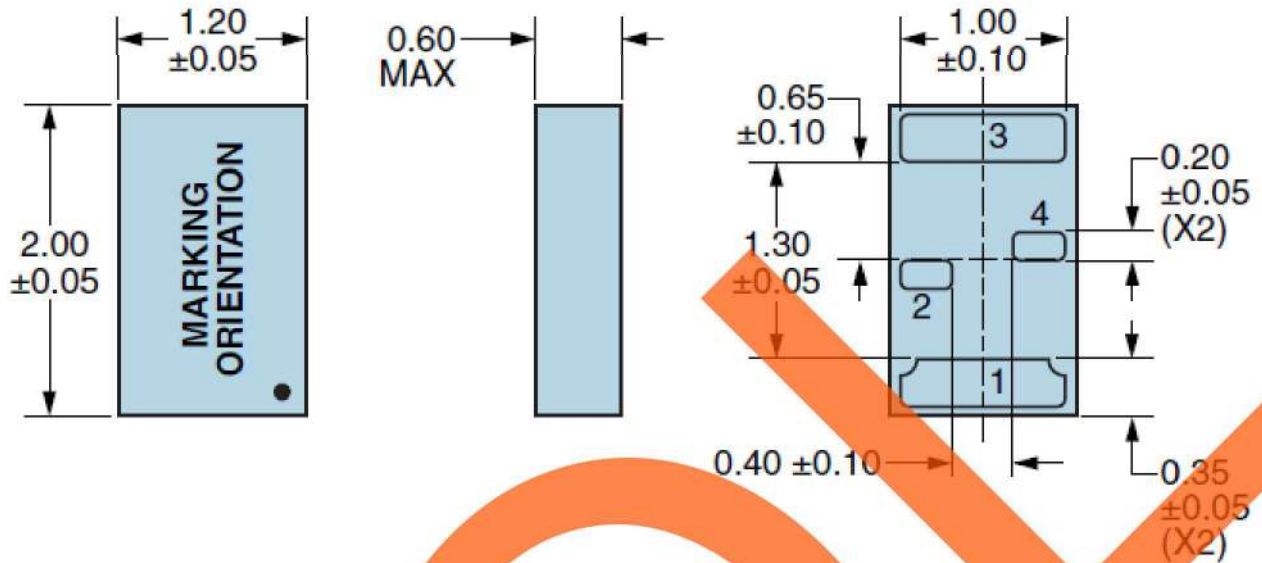

SUGGESTED SOLDER PAD LAYOUT

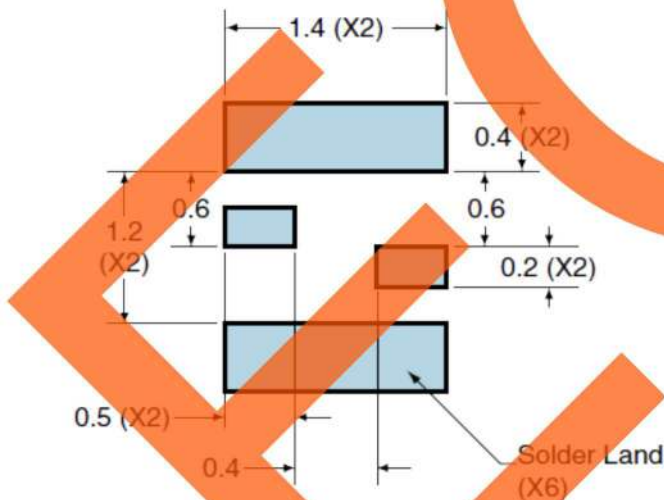

PIN	CONNECTION
1	No Connect
2	Ground
3	Output
4	Supply Voltage

All Tolerances are ±0.1

All Dimensions in Millimeters

OUTPUT WAVEFORM & TIMING DIAGRAM

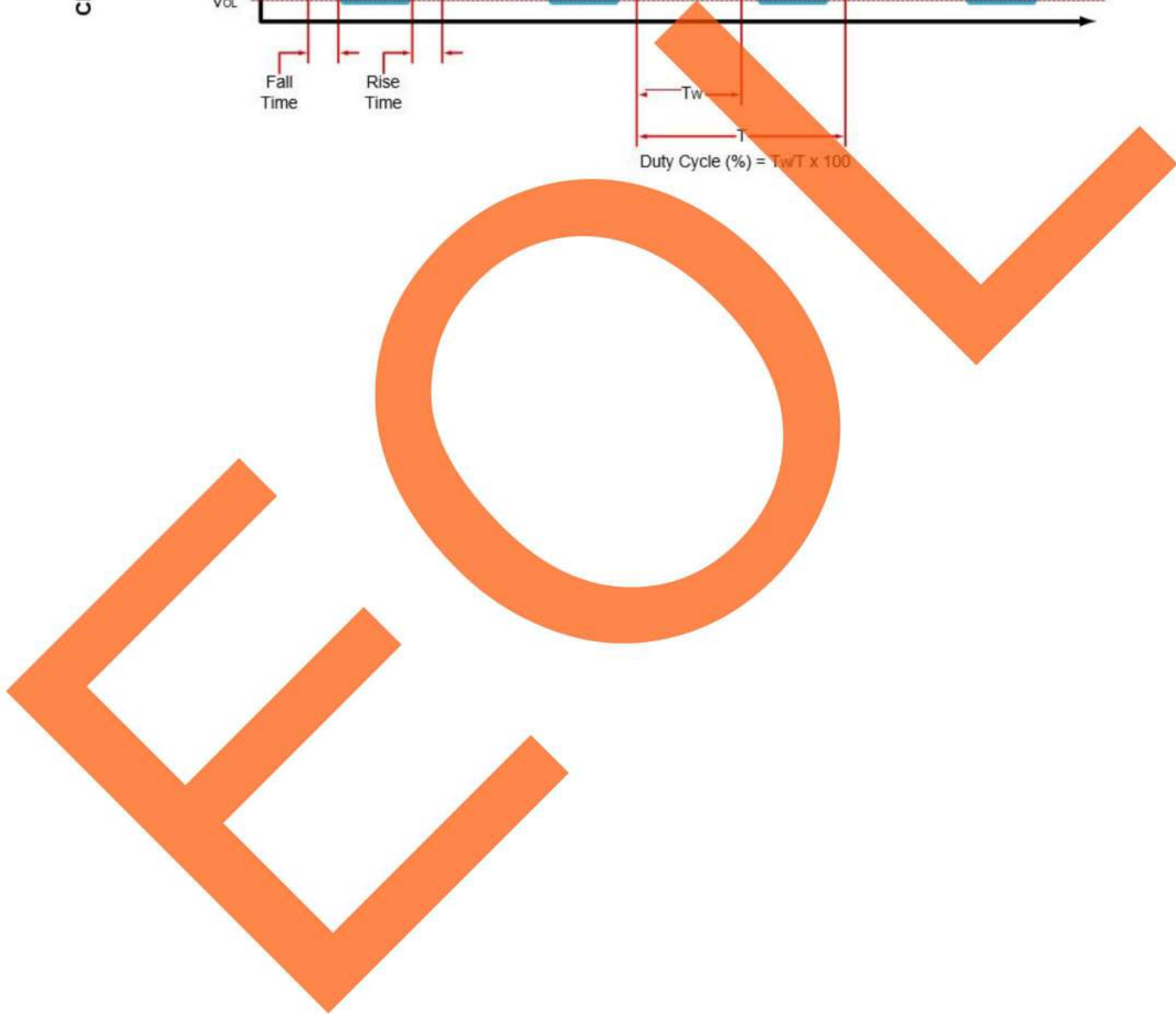
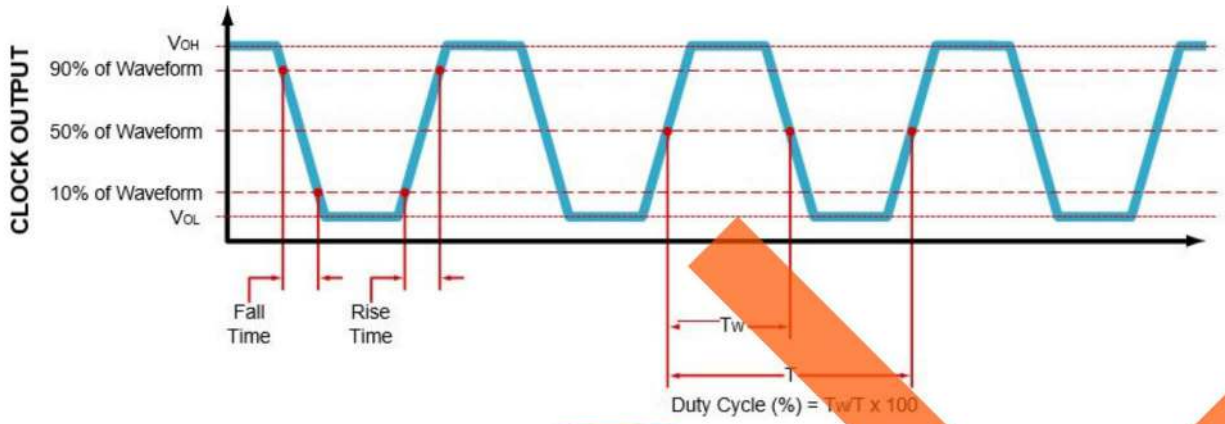

TEST CIRCUIT FOR CMOS OUTPUT

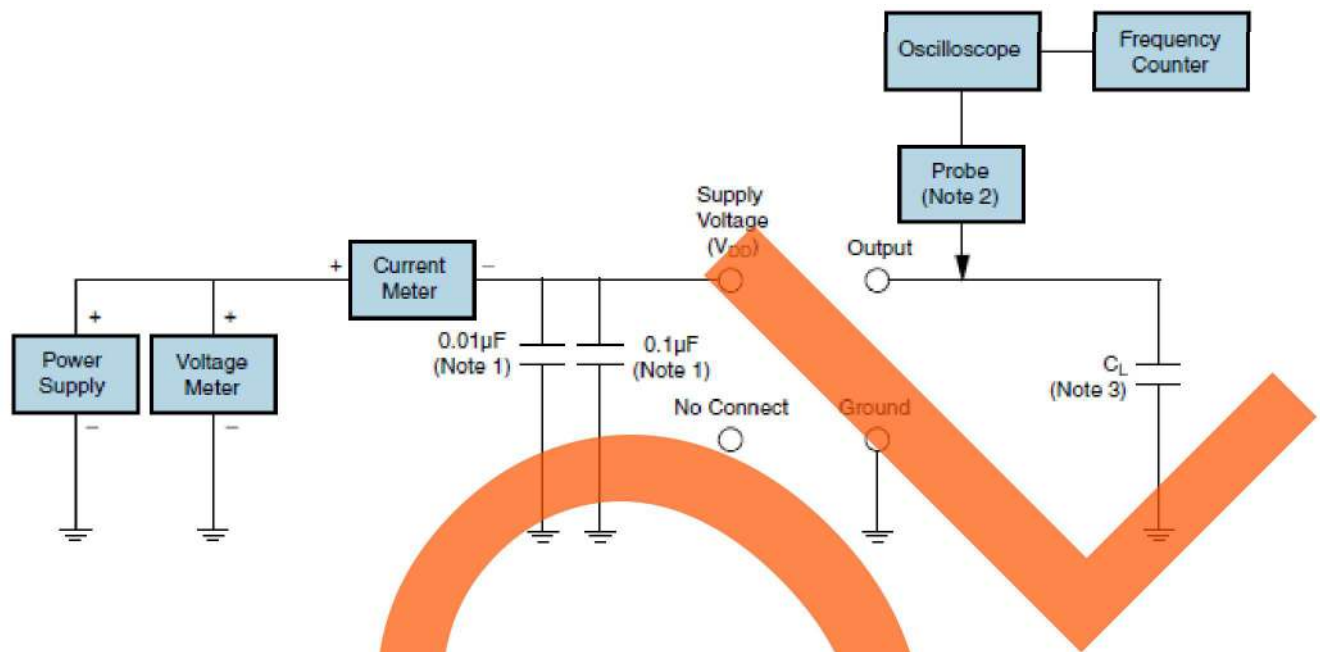

Note 1: An external $0.01\mu\text{F}$ ceramic bypass capacitor in parallel with a $0.1\mu\text{F}$ high frequency ceramic bypass capacitor (less than 2mm) to the package ground and supply voltage pin is required.

Note 2: A low input capacitance ($<12\text{pF}$), 10X attenuation factor, high impedance ($>10\text{Mohms}$), and high bandwidth ($>300\text{MHz}$) Passive probe is recommended.

Note 3: Capacitance value C_L includes sum of all probe and fixture capacitance. See applicable specification sheet for 'Load Drive Capability'.

TAPE & REEL DIMENSIONS

Quantity per Reel: 3000 Units

All Dimensions in Millimeters

Compliant to EIA-481

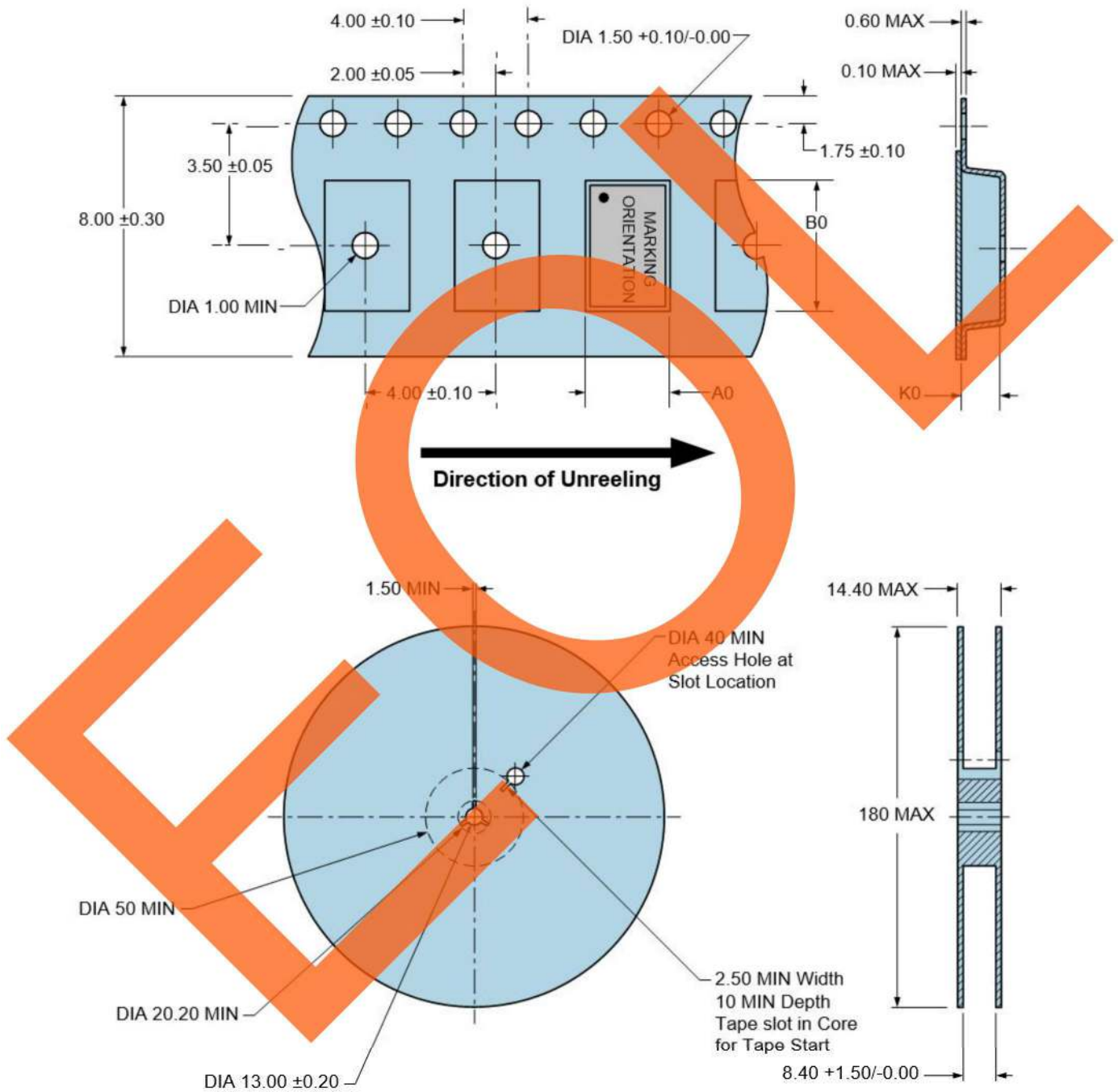

RECOMMENDED SOLDER REFLOW METHOD

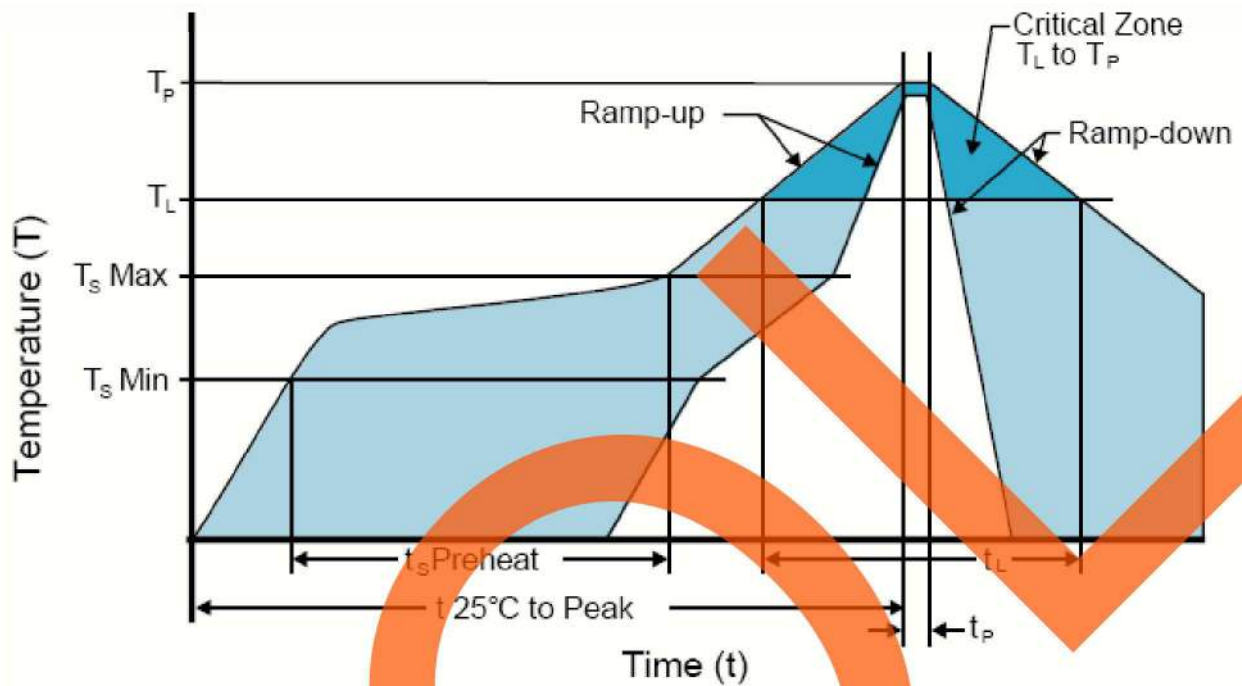

HIGH TEMPERATURE INFRARED/CONVECTION

T _S MAX to T _L (Ramp-up Rate)	3°C/Second Maximum
Preheat	
- Temperature Minimum (T _S MIN)	150°C
- Temperature Typical (T _S TYP)	175°C
- Temperature Maximum (T _S MAX)	200°C
- Time (t _s)	60 - 180 Seconds
Ramp-up Rate (T _L to T _P)	3°C/Second Maximum
Time Maintained Above:	
- Temperature (T _L)	217°C
- Time (t _L)	60 - 150 Seconds
Peak Temperature (T _P)	260°C Maximum for 10 Seconds Maximum
Target Peak Temperature (T _P Target)	250°C +0/-5°C
Time within 5°C of actual peak (t _p)	20 - 40 Seconds
Ramp-down Rate	6°C/Second Maximum
Time 25°C to Peak Temperature (t)	8 Minutes Maximum
Moisture Sensitivity Level	Level 1
Additional Notes	Temperatures shown are applied to body of device.

High Temperature Manual Soldering

260°C Maximum for 5 Seconds Maximum, 2 times Maximum. (Temperatures shown are applied to body of device.)

RECOMMENDED SOLDER REFLOW METHOD

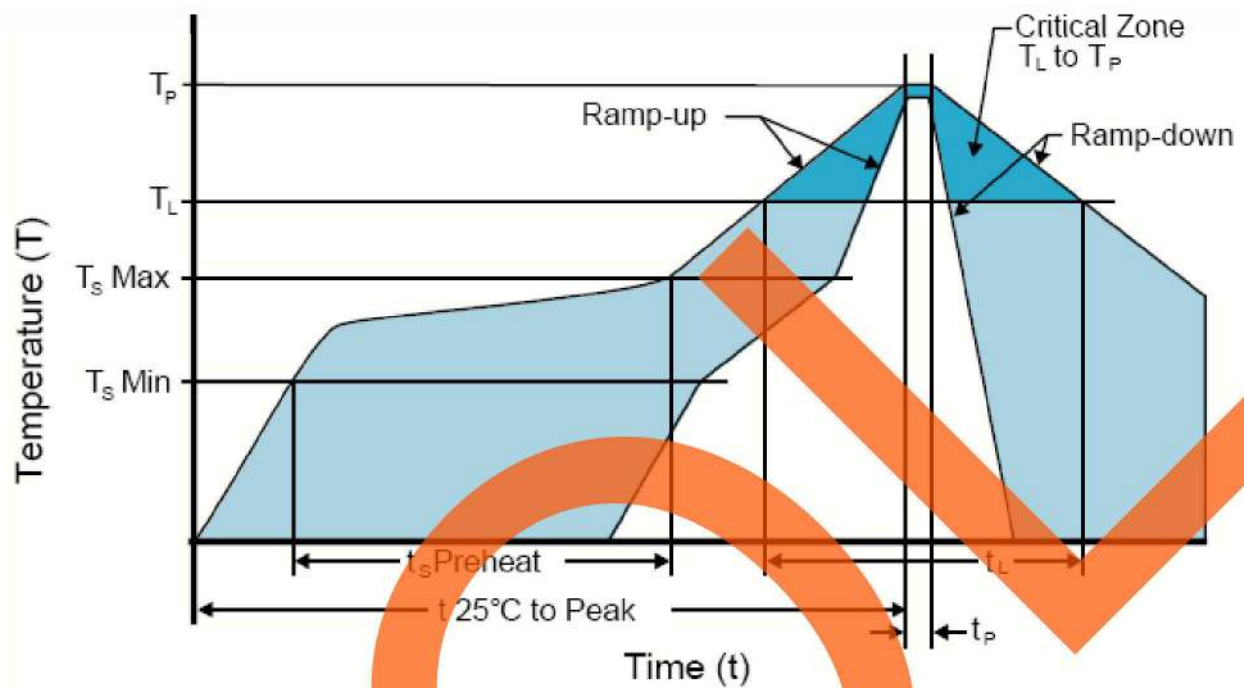

LOW TEMPERATURE INFRARED/CONVECTION

T_s MAX to T_L (Ramp-up Rate)	5°C/Second Maximum
Preheat	
- Temperature Minimum (T_s MIN)	N/A
- Temperature Typical (T_s TYP)	150°C
- Temperature Maximum (T_s MAX)	N/A
- Time (t_s)	60 - 120 Seconds
Ramp-up Rate (T_L to T_P)	5°C/Second Maximum
Time Maintained Above:	
- Temperature (T_L)	150°C
- Time (t_L)	200 Seconds Maximum
Peak Temperature (T_P)	240°C Maximum
Target Peak Temperature (T_P Target)	240°C Maximum 2 Times / 230°C Maximum 1 Time
Time within 5°C of actual peak (t_p)	10 Seconds Maximum 2 Times / 80 Seconds Maximum 1 Time
Ramp-down Rate	5°C/Second Maximum
Time 25°C to Peak Temperature (t)	N/A
Moisture Sensitivity Level	Level 1
Additional Notes	Temperatures shown are applied to body of device.

Low Temperature Manual Soldering

185°C Maximum for 10 Seconds Maximum, 2 times Maximum. (Temperatures shown are applied to body of device.)