

# PU SERIES INSTALLATION & DIMENSIONS

**Step 1** Tap motor shaft for 10-32 screw, 1/2" deep

**Step 2** Remove cap from screw

**Step 3** Remove black dust cover

**Step 4** Install and tighten PU assembly

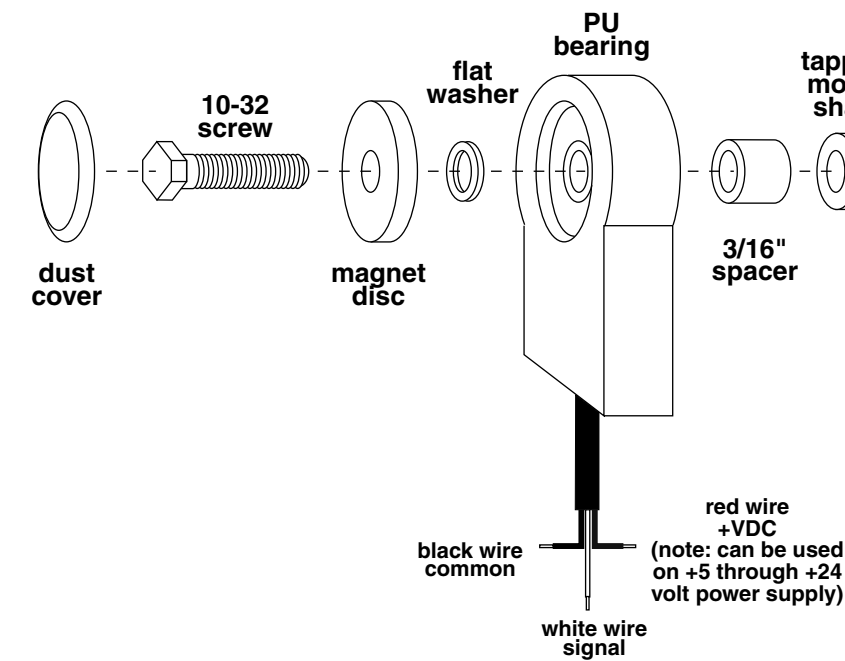

**Step 5** Secure black cover onto housing

No other screws are necessary, as the cord will keep the unit from rotating. The PU gives a high signal when the North Pole in the magnet crosses the hall-effect transistor. The signal is switched off when the South Pole crosses the hall-effect transistor. The result is a square wave whose frequency is proportional to the speed of the shaft that the PU is mounted on. The number of North/South Pole pairs directly affects the output.

Note:

If installing the unit on a motor purchased from Dart, the motor shaft is already drilled and tapped. If the motor is fan-cooled (TENV), remove the plug in the center of the fan guard before installing the pickup. Otherwise, damage to the pickup may occur.

