



**Please note that Cypress is an Infineon Technologies Company.**

The document following this cover page is marked as “Cypress” document as this is the company that originally developed the product. Please note that Infineon will continue to offer the product to new and existing customers as part of the Infineon product portfolio.

**Continuity of document content**

The fact that Infineon offers the following product as part of the Infineon product portfolio does not lead to any changes to this document. Future revisions will occur when appropriate, and any changes will be set out on the document history page.

**Continuity of ordering part numbers**

Infineon continues to support existing part numbers. Please continue to use the ordering part numbers listed in the datasheet for ordering.



# Traveo II Starter Kit

## User Guide

Document Number: 002-25314 Rev. \*B

Cypress Semiconductor  
An Infineon Technologies Company  
198 Champion Court  
San Jose, CA 95134-1709  
[www.cypress.com](http://www.cypress.com)  
[www.infineon.com](http://www.infineon.com)

## Copyrights

© Cypress Semiconductor Corporation, 2018-2020. This document is the property of Cypress Semiconductor Corporation and its subsidiaries (“Cypress”). This document, including any software or firmware included or referenced in this document (“Software”), is owned by Cypress under the intellectual property laws and treaties of the United States and other countries worldwide. Cypress reserves all rights under such laws and treaties and does not, except as specifically stated in this paragraph, grant any license under its patents, copyrights, trademarks, or other intellectual property rights. If the Software is not accompanied by a license agreement and you do not otherwise have a written agreement with Cypress governing the use of the Software, then Cypress hereby grants you a personal, non-exclusive, nontransferable license (without the right to sublicense) (1) under its copyright rights in the Software (a) for Software provided in source code form, to modify and reproduce the Software solely for use with Cypress hardware products, only internally within your organization, and (b) to distribute the Software in binary code form externally to end users (either directly or indirectly through resellers and distributors), solely for use on Cypress hardware product units, and (2) under those claims of Cypress’s patents that are infringed by the Software (as provided by Cypress, unmodified) to make, use, distribute, and import the Software solely for use with Cypress hardware products. Any other use, reproduction, modification, translation, or compilation of the Software is prohibited.

TO THE EXTENT PERMITTED BY APPLICABLE LAW, CYPRESS MAKES NO WARRANTY OF ANY KIND, EXPRESS OR IMPLIED, WITH REGARD TO THIS DOCUMENT OR ANY SOFTWARE OR ACCOMPANYING HARDWARE, INCLUDING, BUT NOT LIMITED TO, THE IMPLIED WARRANTIES OF MERCHANTABILITY AND FITNESS FOR A PARTICULAR PURPOSE. No computing device can be absolutely secure. Therefore, despite security measures implemented in Cypress hardware or software products, Cypress shall have no liability arising out of any security breach, such as unauthorized access to or use of a Cypress product. CYPRESS DOES NOT REPRESENT, WARRANT, OR GUARANTEE THAT CYPRESS PRODUCTS, OR SYSTEMS CREATED USING CYPRESS PRODUCTS, WILL BE FREE FROM CORRUPTION, ATTACK, VIRUSES, INTERFERENCE, HACKING, DATA LOSS OR THEFT, OR OTHER SECURITY INTRUSION (collectively, “Security Breach”). Cypress disclaims any liability relating to any Security Breach, and you shall and hereby do release Cypress from any claim, damage, or other liability arising from any Security Breach. In addition, the products described in these materials may contain design defects or errors known as errata which may cause the product to deviate from published specifications. To the extent permitted by applicable law, Cypress reserves the right to make changes to this document without further notice. Cypress does not assume any liability arising out of the application or use of any product or circuit described in this document. Any information provided in this document, including any sample design information or programming code, is provided only for reference purposes. It is the responsibility of the user of this document to properly design, program, and test the functionality and safety of any application made of this information and any resulting product. “High-Risk Device” means any device or system whose failure could cause personal injury, death, or property damage. Examples of High-Risk Devices are weapons, nuclear installations, surgical implants, and other medical devices. “Critical Component” means any component of a High-Risk Device whose failure to perform can be reasonably expected to cause, directly or indirectly, the failure of the High-Risk Device, or to affect its safety or effectiveness. Cypress is not liable, in whole or in part, and you shall and hereby do release Cypress from any claim, damage, or other liability arising from any use of a Cypress product as a Critical Component in a High-Risk Device. You shall indemnify and hold Cypress, its directors, officers, employees, agents, affiliates, distributors, and assigns harmless from and against all claims, costs, damages, and expenses, arising out of any claim, including claims for product liability, personal injury or death, or property damage arising from any use of a Cypress product as a Critical Component in a High-Risk Device. Cypress products are not intended or authorized for use as a Critical Component in any High-Risk Device except to the limited extent that (i) Cypress’s published data sheet for the product explicitly states Cypress has qualified the product for use in a specific High-Risk Device, or (ii) Cypress has given you advance written authorization to use the product as a Critical Component in the specific High-Risk Device and you have signed a separate indemnification agreement.

Cypress, the Cypress logo, Spansion, the Spansion logo, and combinations thereof, WICED, PSoC, CapSense, EZ-USB, F-RAM, and Traveo are trademarks or registered trademarks of Cypress in the United States and other countries. For a more complete list of Cypress trademarks, visit [cypress.com](http://cypress.com). Other names and brands may be claimed as property of their respective owners.

### Disclaimer of B. Schematics and Layouts

This material constitutes a reference design. CYPRESS MAKES NO WARRANTY OF ANY KIND, EXPRESS OR IMPLIED, WITH REGARD TO THIS MATERIAL, INCLUDING, BUT NOT LIMITED TO, THE IMPLIED WARRANTIES OF MERCHANTABILITY AND FITNESS FOR A PARTICULAR PURPOSE. Cypress reserves the right to make changes without further notice to the materials described herein. Cypress does not assume any liability arising out of the application or use of any product or circuit described herein. Cypress does not authorize its products for use as critical components in life-support systems where a malfunction or failure may reasonably be expected to result in significant injury to the user. The inclusion of Cypress products in a life-support systems application implies that the manufacturer assumes all risk of such use and in doing so indemnifies Cypress against all changes.



## Using the Product Safely

This guide contains important information about using this product safely. Be sure to read this guide before using the product and to follow the directions given to use the product correctly. In particular, read “Product Caution” and perform a thorough safety check before using the product.

Store this guide in a safe location where it can easily be accessed at any time while you are using the product.

## Related Documents

- Traveo™ II Automotive Body Controller Entry Family Architecture Technical Reference Manual (TRM), 002-19314
- Traveo™ II Automotive Body Controller Entry Registers Technical Reference Manual (TRM) for CYT2B7, 002-19567
- Traveo™ II Automotive Body Controller Entry Registers Technical Reference Manual (TRM) for CYT2B9, 002-27181
- CYT2B7 Datasheet 32-bit Arm® Cortex®-M4F Microcontroller Traveo™ II Family, 002-18043
- CYT2B9 Datasheet 32-bit Arm® Cortex®-M4F Microcontroller Traveo™ II Family, 002-22825

## Notice on This Document

All information included in this document is current as of the date it is issued. Such information is subject to change without any prior notice.

Please confirm the latest relevant information with Cypress sales representatives.

## Target Product

The following product is the target for this evaluation board.

Quantity	Description	Part No.
1	Traveo II Starter Kit	CYTVII-B-E-1M-SK

## Board Size

114 x 52 (mm).

## Operating Temperature

0 to 40 °C.

## **RoHS Compliance**

European RoHS.

# Contents



<b>1. Introduction</b>	<b>6</b>
1.1 Precautions and Warnings.....	6
<b>2. Overview</b>	<b>8</b>
2.1 Functional Overview .....	9
<b>3. Operation Points and Locations</b>	<b>11</b>
3.1 Power Supply.....	11
3.2 Main Clock .....	12
3.3 Switches .....	13
3.4 LEDs .....	14
3.5 USB Interface Connector.....	15
3.6 CAN FD Interface Connector.....	16
3.7 Potentiometer .....	17
3.8 Arduino Compatible Pin Headers .....	18
3.9 Debug Interface (Optional) .....	21
<b>4. Known Limitations</b>	<b>22</b>
4.1 Known Limitations.....	22
<b>A. Connections and Settings</b>	<b>23</b>
A.1 Traveo II Starter Kit Connections.....	23
A.1.1 User LED.....	23
A.1.2 User SW.....	23
A.1.3 RESET SW .....	23
A.1.4 MODE SW.....	24
<b>B. Schematics and Layouts</b>	<b>25</b>
B.1 Schematics .....	25
B.2 Layouts .....	36
<b>Revision History</b>	<b>38</b>

# 1. Introduction



This guide provides directions for using the Traveo™ II Starter Kit, which is the evaluation environment for Traveo II Body Entry devices of the Cypress Traveo II family 32-bit microcontroller.

Table 1-1. Contents - Traveo II Starter Kit Board

Quantity	Description	Part No.
1	Traveo II Starter Kit Rev 3.0	CYTVII-B-E-1M-SK

**Note:** This user guide is meant for Rev 3.0 of the Traveo II Starter Kit.

## 1.1 Precautions and Warnings

The following precautions apply to the product described in this manual:

<b>Warning</b>	Indicates a potentially hazardous situation which could result in death or serious injury and/or a fault in the user's system if the product is not used correctly.
<b>Electric shock, Damage</b>	Before performing any operation described in this manual, turn OFF all the power supplies to the system.
	Performing such an operation with the power ON may cause an electric shock or device fault.
	Once the product has been turned ON, do not touch any metal part of it.
	Doing so may cause an electric shock or device fault.
<b>Caution</b>	Indicates a hazardous situation that may cause a minor or moderate injury, damages to this product or devices connected to it, or loss of software resources and other properties such as data, if the device is not used appropriately.
<b>Cuts, Damage</b>	Before moving the product, be sure to turn OFF all the power supplies and unplug the cables. Watch your step when carrying the product. Do not use the product in an unstable location such as a place exposed to strong vibration or with slopes.
	Doing so may cause the product to fall, resulting in an injury or fault.
<b>Damage</b>	Do not place anything on the product or expose the product to physical shocks. Do not carry the product after the power has been turned ON.
	Doing so may cause a malfunction due to overloading or shock.
	Since the product contains many electronic components, keep it away from direct sunlight, high temperature, and high humidity to prevent condensation. Do not use or store the product where it is exposed to much dust or a strong magnetic or electric field for an extended period.
	Inappropriate operating or storage environments may cause a fault.

<b>Damage</b>	Use the product within the ranges given in the specifications.
	Operation over the specified ranges may cause a fault.
	To prevent electrostatic breakdown, do not let your finger or other object come in contact with the metal parts of any connectors. Before handling the product, touch a metal object (such as a door knob) to discharge any static electricity from your body.
	When installing the sub board, align the key positions of main board connector and sub board connector, and fix with the screw set before use. When removing, remove all screws of screw set, and then remove the sub board vertically from the main board. Otherwise, the product may be damaged, for example, the connector section might be corrupted.
	The product has no casing, so it is recommended that it be stored in the original packaging. Transporting the product may cause a damage or fault. Therefore, keep the packaging materials and use them when re-shipping the product.



## 2. Overview



This evaluation board provides developers with the evaluation environment of the CYT2B75/95 MCU.

Figure 2-1. Traveo II Starter Kit Board - Top View

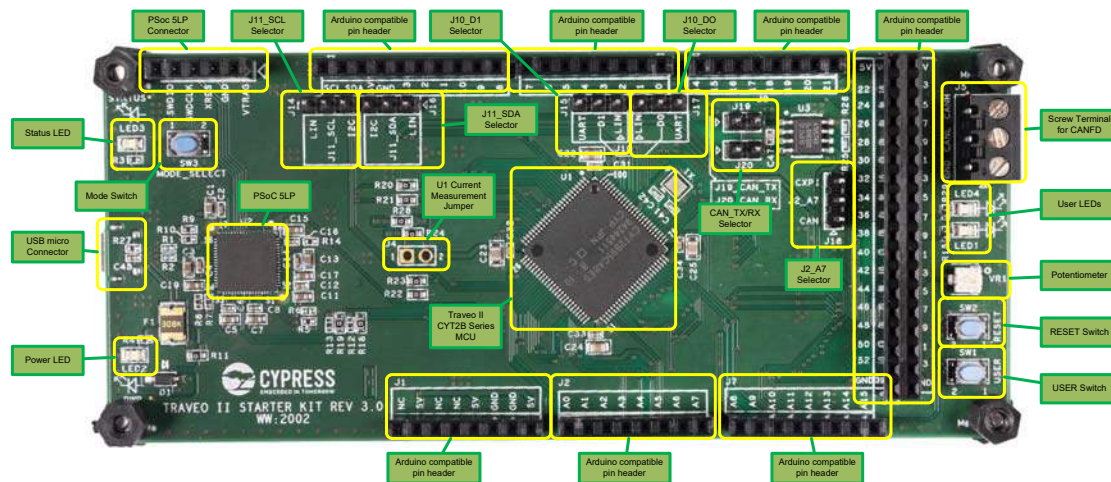

## 2.1 Functional Overview

This board can mount the CYT2B75/95 series of MCU. The location of the main function is shown in [Figure 2-2](#).

Figure 2-2. Traveo II Starter Kit Functional Overview

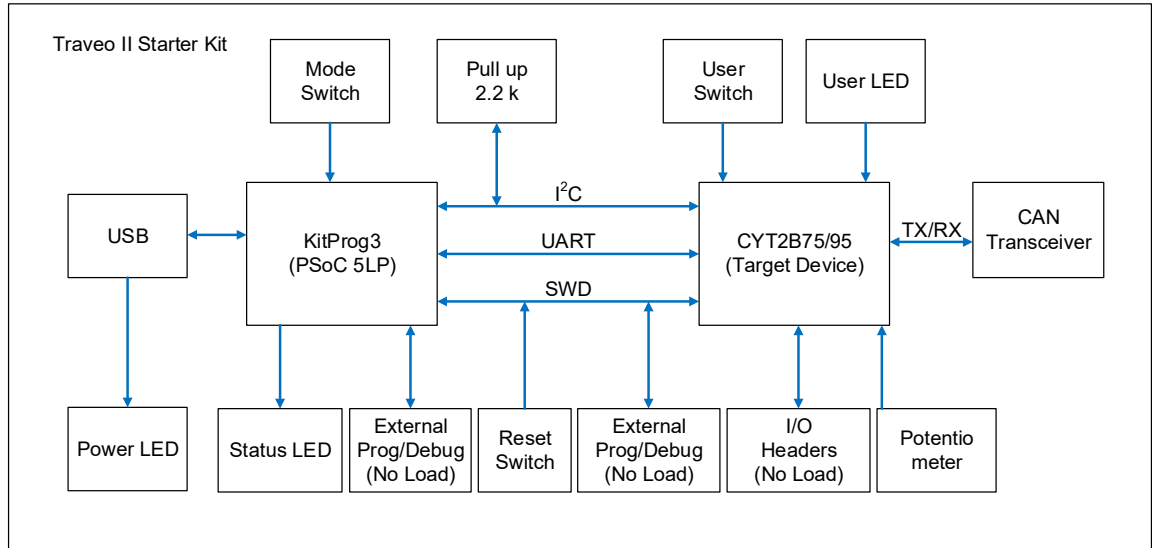

Table 2-1. Traveo II Starter Kit Functions

Item	Function	Specification	Remarks
Traveo II Starter Kit	MCU	CYT2B75XX CYT2B95XX	U1: QFP 100-pin (0.5-mm pitch)
	Oscillator (optional)	Main clock 16 MHz Surface mounted main crystal oscillator and load capacitances (10 pF)	X1: ABM10-16.000MHZ-D30-T3
	PSoC 5LP Kit-Prog3	CY8C5868LTI-LP039	U2: QFN 68-pin
	Reset SW	System reset switch	SW2
	User SW	User switch connects to MCU	SW1
	Mode SW	Mode switch connects to PSoC	SW3
	User LEDs	Two User LEDs connected to MCU	LED1 Blue LED4 Blue
	Power LED	Power monitor LED	LED2 Green
	Status LED	KitProg3 status LED	LED3 Amber
	USB connector	USB micro connector	J8: 10118194-0001LF
	CAN FD interface	CAN FD channel CAN0_1	J5: CAN0_1 (Screw Terminal) U3: TJA1057GT
	Potentiometer	Potentiometer 10 kΩ	VR1: 3313J-1-103E
	Arduino compatible pin headers	Header 2.54-mm pitch 8 x 1	J1, J2, J7, J9, J10
		Header 2.54-mm pitch 10 x 1	J11
		Header 2.54-mm pitch 18 x 2	J13
Debug connector (optional)	MIPI-10/20 Arm JTAG	J3: FTSH-110-01-L-DV-K Not mounted by default	

# 3. Operation Points and Locations



## 3.1 Power Supply

Power is supplied to this board from USB with a resettable fuse.

The current consumption can be measured at J4. J4 is not mounted by default, and instead R24 is mounted. To measure current consumption, remove R24 and mount J4.

Figure 3-1. MCU Power Supply Jumper Locations

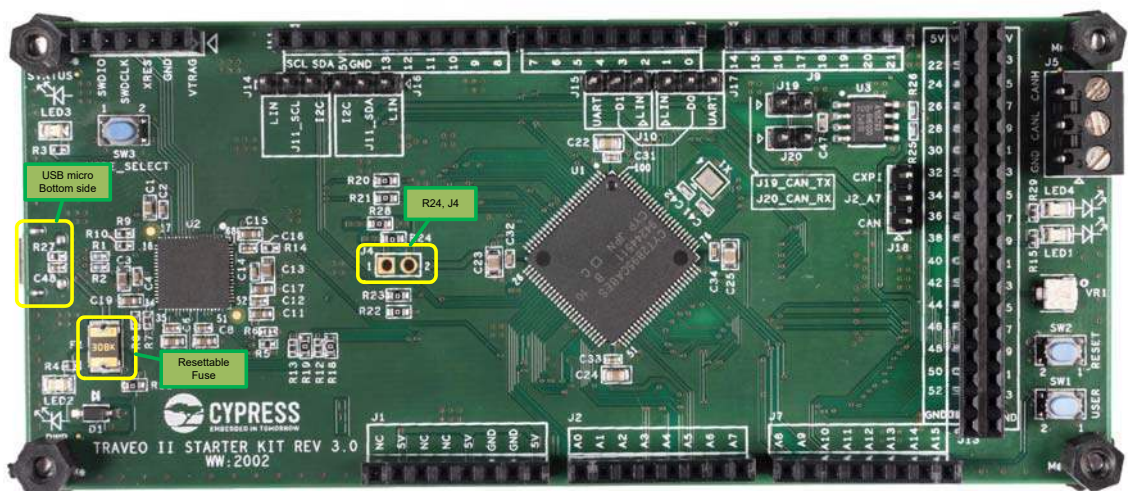

### 3.2 Main Clock

The main clock (X1) location and details are shown in [Figure 3-2](#) and [Table 3-1](#).

X1 is a 16-MHz oscillator with load capacitance.

Figure 3-2. Main Clock Location

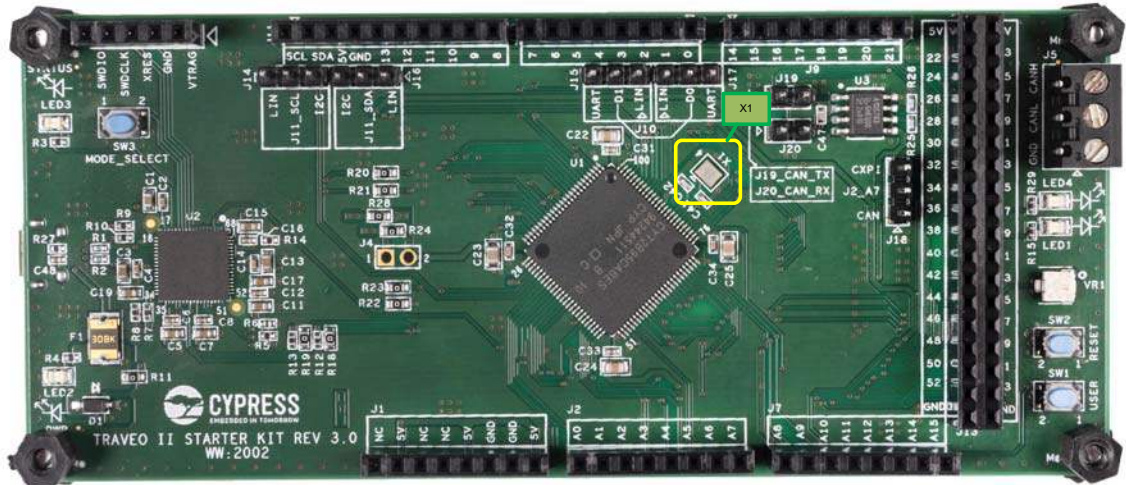

Table 3-1. Main Clock Oscillator

Part No.	Model Number	Remarks
X1	ABM10-16.000MHZ-D30-T3	ABRACON Surface-mounted 16-MHz oscillator

### 3.3 Switches

This board has various switches for performing certain operations. The location and details of these switches are shown in [Figure 3-3](#) and [Table 3-2](#).

Figure 3-3. Switches Location

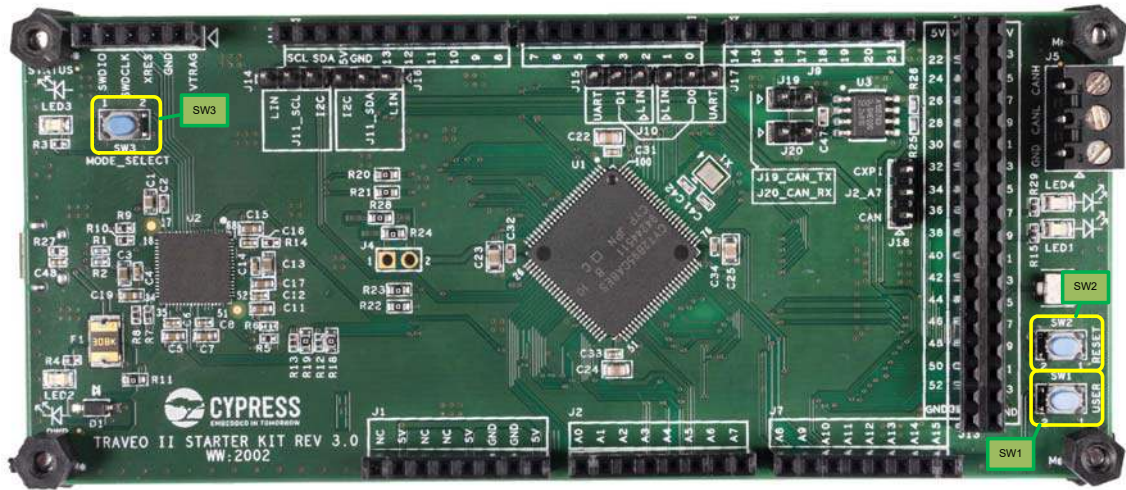

Table 3-2. Switches

Part No.	Signal Name
SW1	User Switch: Connects to P7.0 of MCU
SW2	Reset Switch: System Reset
SW3	Mode Switch: Connects to P1[2] of PSoC 5LP

### 3.4 LEDs

This board has various LEDs for condition indication. The location and details of these LEDs are shown in [Figure 3-4](#) and [Table 3-3](#).

Figure 3-4. LED Location



Table 3-3. LEDs

Part No.	Description
LED 1	User LED: Blue, Connects to P19.0 of DUT MCU
LED 2	Power LED: Green, Power monitor LED (VBUS)
LED 3	User LED: Amber, Connects to P1.4 of PSoC
LED 4	User LED: Blue, Connects to P12.2 of MCU

### 3.5 USB Interface Connector

This board has USB micro connector on the bottom side. SWD protocol is implemented on PSoC over USB and is connected to MCU. The location and details of USB micro connector are shown in Figure 3-5 and Table 3-4.

Figure 3-5. USB Interface Connector Location

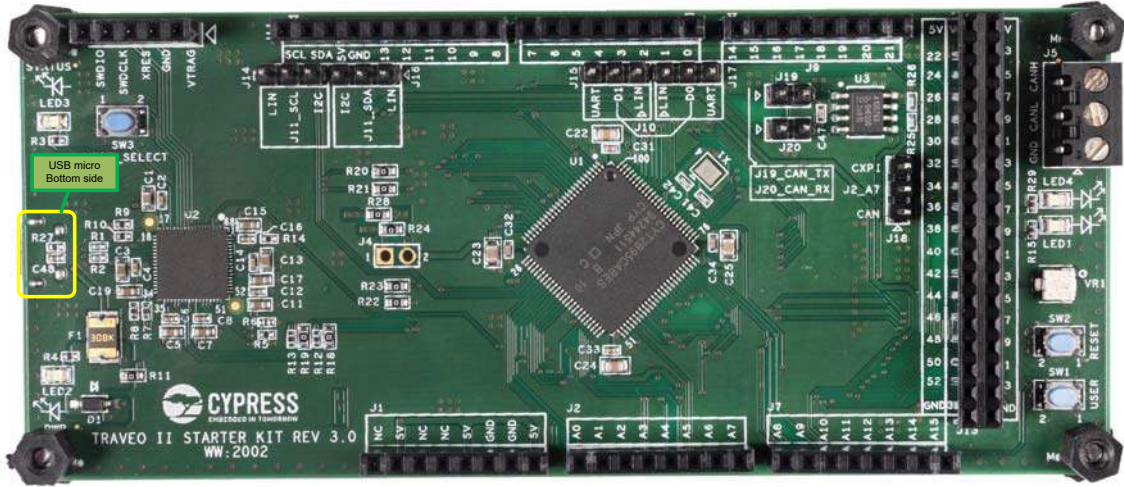

Table 3-4. USB Interface Connector

Part No.	Description	Remarks
J8	USB micro connector 10118194-0001LF	FCI This connector is mounted on the bottom side



### 3.6 CAN FD Interface Connector

This board has a CAN FD interface. It is connected to a CAN FD channel of the DUT MCU.

The connector of CAN FD is 3-pin header. It is optional (not mounted by default). The CAN FD interface connector location and details are shown in [Figure 3-6](#) and [Table 3-5](#).

Figure 3-6. CAN FD Interface Connector Location

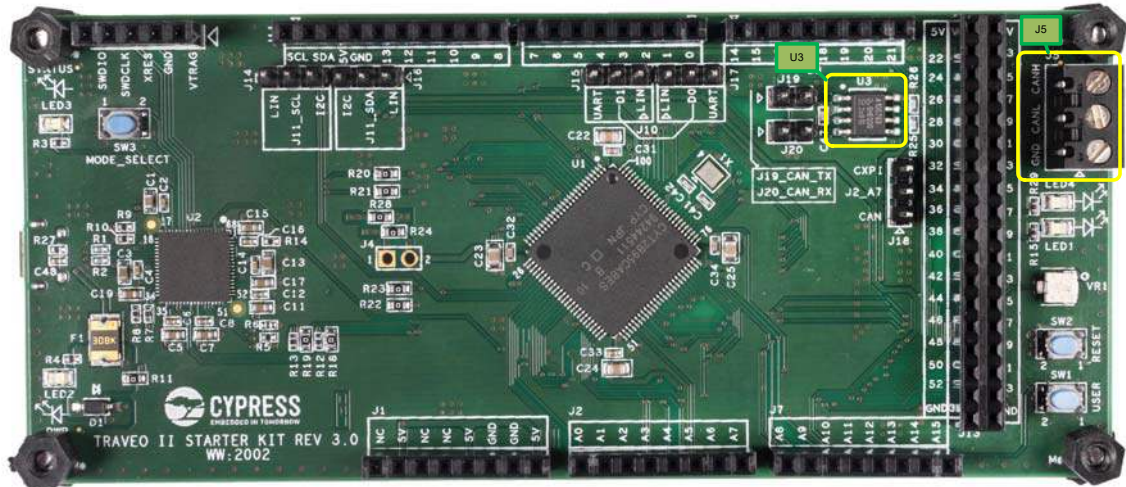

Table 3-5. CAN FD Interface

Part No.	Description	Remarks
U3	CAN FD Transceiver TJA1057GT	NXP Connects to P0.2 and P0.3 (CAN0_1) of MCU
J5	3-pin header (Screw terminal)	1: GND Common ground 2: CANL CAN0_1 bus signal LOW 3: CANH CAN0_1 bus signal HIGH

### 3.7 Potentiometer

This board has a potentiometer. It is connected to an ADC channel of the MCU.

The potentiometer location and details are shown in [Figure 3-7](#) and [Table 3-6](#).

Figure 3-7. Potentiometer Location



Table 3-6. Potentiometer

Part No.	Description	Remarks
VR1	Potentiometer 10 kΩ 3313J-1-103E	BOURNS Connects to P6.0 (ADC[0]_0) of MCU

### 3.8 Arduino Compatible Pin Headers

This board has Arduino compatible pin headers to monitor MCU signals.

The location and details of I/O headers are shown in [Figure 3-8](#), [Table 3-7](#), [Table 3-8](#), [Table 3-9](#), [Table 3-10](#), [Table 3-11](#), [Table 3-12](#) and [Table 3-13](#).

Figure 3-8. Arduino Compatible Pin Headers Location

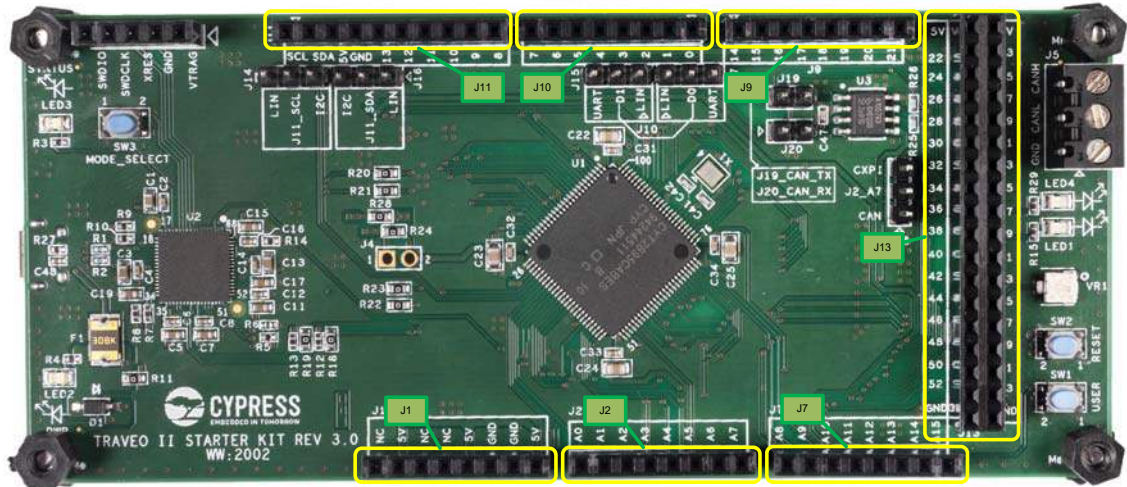

Table 3-7. Arduino Compatible Pin Header 1 (J1)

Pin	Signal
1	NC
2	5V
3	NC
4	NC
5	5V
6	GND
7	GND
8	5V

Table 3-8. Arduino Compatible Pin Header 2 (J2)

Pin	Signal
1	A0 (P7_5)
2	A1 (P7_4)
3	A2 (P7_3)
4	A3 (P6_5)
5	A4 (P6_4)
6	A5 (P13_2)
7	A6 (P12_1)
8	A7

Table 3-9. Arduino Compatible Pin Header 3 (J7)

Pin	Signal
1	A8 (P7_0)
2	A9 (P18_6)
3	A10 (P18_7)
4	NC
5	NC
6	NC
7	NC
8	NC

Table 3-10. Arduino Compatible Pin Header 4 (J9)

Pin	Signal
1	14 (P18_1)
2	15 (P18_0)
3	16 (17_2)
4	17 (17_1)
5	18 (14_1)
6	19 (14_0)
7	20 (P0_3)
8	21 (P0_2)

Table 3-11. Arduino Compatible Pin Header 5 (J10)

Pin	Signal
1	0
2	1
3	2 (P19_1)
4	3 (P19_2)
5	4 (P21_0)
6	5 (P21_1)
7	6 (P13_3)
8	7 (P13_5)

Table 3-12. Arduino Compatible Pin Header 6 (J11)

Pin	Signal
1	SCL
2	SDA
3	5V
4	GND
5	13 (P22_2)
6	12 (P22_0)
7	11 (P22_1)
8	10 (P22_3)
9	9 (P23_3)
10	8 (P21_5)

Table 3-13. Arduino Compatible Pin Header 7 (J13)

Pin	Signal	Pin	Signal
1	5V	2	5V
3	22 (P11_2)	4	23 (P11_1)
5	24 (P11_0)	6	25 (P8_2)
7	26 (P8_1)	8	27 (P18_2)
9	28 (P17_0)	10	29 (P14_3)
11	30 (P14_2)	12	31 (P13_7)
13	32 (P13_6)	14	33 (P13_4)
15	34 (P8_0)	16	35 (P3_0)
17	36 (P2_3)	18	37 (P12_4)
19	38 (P12_3)	20	39 (P12_2)
21	40 (P19_0)	22	41 (P3_1)
23	42 (P5_3)	24	43 (P2_0)
25	44 (P5_0)	26	45 (P5_1)
27	46 (P5_2)	28	47 (P18_3)
29	48 (P18_4)	30	49 (P18_5)
31	50 (P6_0)	32	51 (P6_1)
33	52 (P6_2)	34	53 (P6_3)
35	GND	36	GND

### 3.9 Debug Interface (Optional)

This board has a MIPI-10/20 (Arm standard) connector as the debugging interface. This connector is not mounted by default.

The debug connector location and details are shown in [Table 3-14](#) and [Table 3-15](#).

Table 3-14. Debug Interface Connector (J3)

Part No.	Description	Remarks
J3	MIPI-20 connector FTSH-110-01-L-DV-K	SAMTEC Not mounted by default (The foot pattern is available on the bottom side)

Table 3-15. MIPI-10/20 Connector

Pin	Signal	Pin	Signal
1	Power	2	TMS
3	Ground	4	TCLK
5	Ground	6	TDO
7	NC	8	TDI
9	Ground	10	XRES
11	Ground	12	TRACE_CLOCK
13	Ground	14	TRACE_DATA_0
15	Ground	16	TRACE_DATA_1
17	Ground	18	TRACE_DATA_2
19	Ground	20	TRACE_DATA_3

## 4. Known Limitations



### 4.1 Known Limitations

This section lists the known limitations of the Traveo II Starter Kit.

Table 4-1. Limitation Information

No.	Problem	Description	Workaround
1	CAN FD communication rate limit	The external oscillator is optional (Not mounted by default) and the CAN FD communication rate is 500 kbps at the maximum with IMO	To evaluate communication rates higher than that, install an external oscillator, or purchase an official evaluation board

# A. Connections and Settings



## A.1 Traveo II Starter Kit Connections

### A.1.1 User LED

The correspondence between the LEDs on the board and the CYT2B75XX/CYT2B95XX device pins and the port pins as in [Table A-1](#).

Table A-1. User LED

User LED	Part Number	CYT2B75XX/CYT2B95XX	
		Pin	Pin Name
USER LED	LED1	77	P19.0
USER LED	LED4	47	P12.2

### A.1.2 User SW

The correspondence between the switch and the CYT2B75XX/CYT2B95XX device pin and the port pin as in [Table A-2](#).

Table A-2. User Switch

User SW	Part Number	CYT2B75XX/CYT2B95XX	
		Pin	Pin Name
USER SW	SW1	29	P7.0

### A.1.3 RESET SW

The correspondence between the RESET SW and the CYT2B75XX/CYT2B95XX device pin and the port pin as in [Table A-3](#).

Table A-3. RESET Switch

RESET SW	Part Number	CYT2B75XX/CYT2B95XX	
		Pin	Pin Name
RESET SW	SW2	85	XRES



#### A.1.4 MODE SW

The correspondence between the MODE SW and the PSoC 5LP pin number is given in [Table A-4](#).

Table A-4. MODE Switch

RESET SW	Part Number	PSoC 5LP	
		Pin	Pin Name
RESET SW	SW3	13	P1[2]

## B. Schematics and Layouts



### B.1 Schematics

Figure B-1. Schematic (1/10)

**BLOCK DIAGRAM**

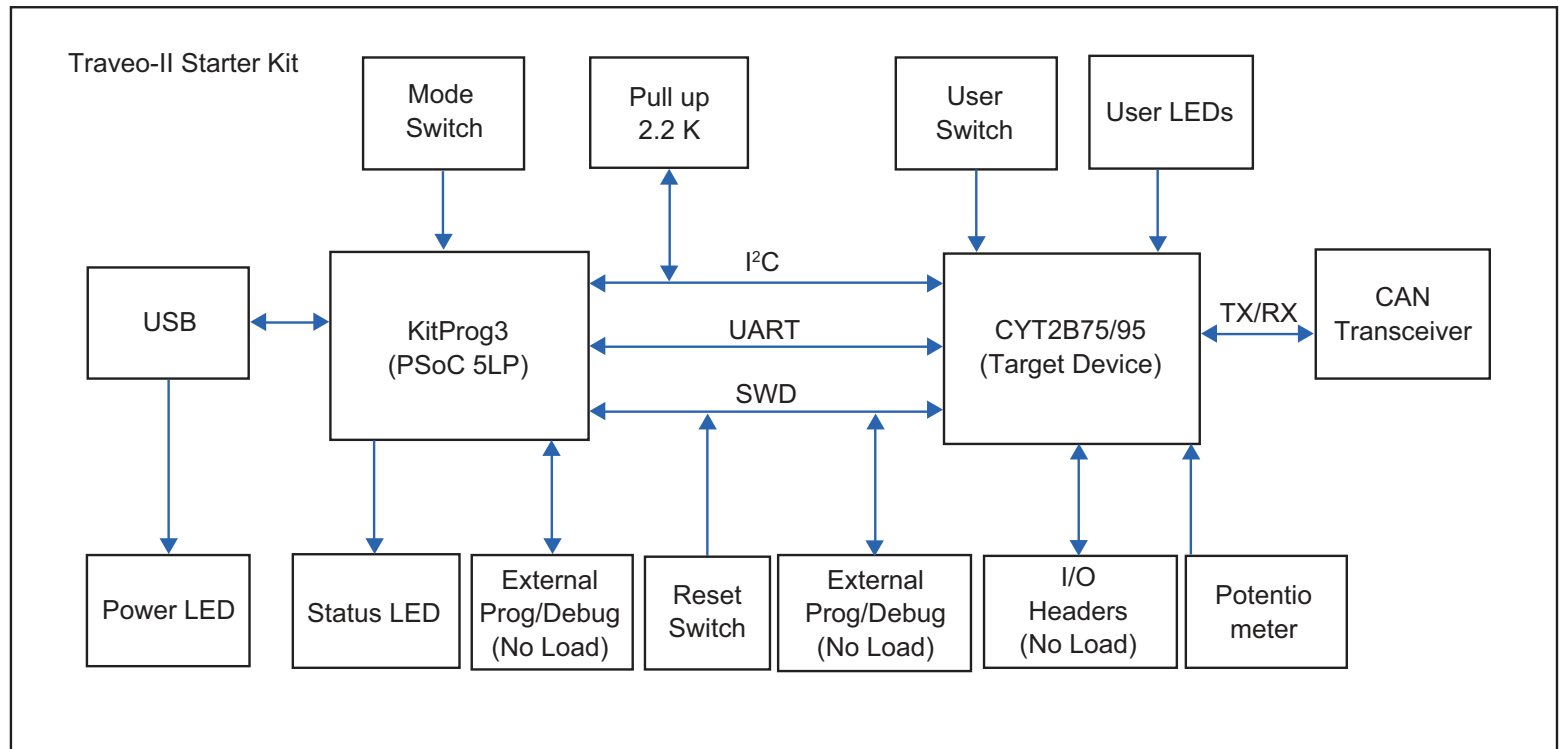

Figure B-2. Schematic (2/10)

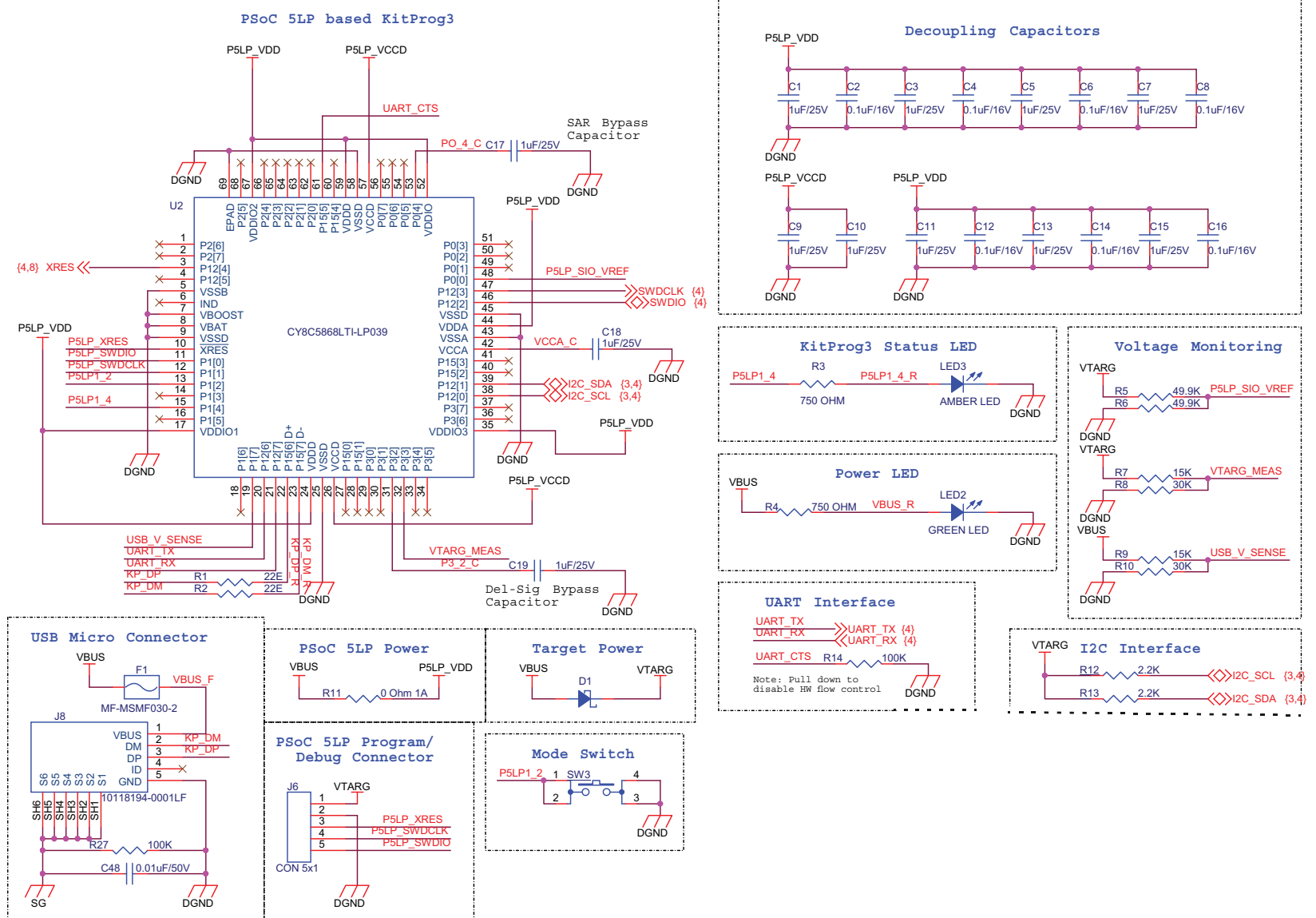

Figure B-3. Schematic (3/10)

TVII Decaps, clock, reset, and debug

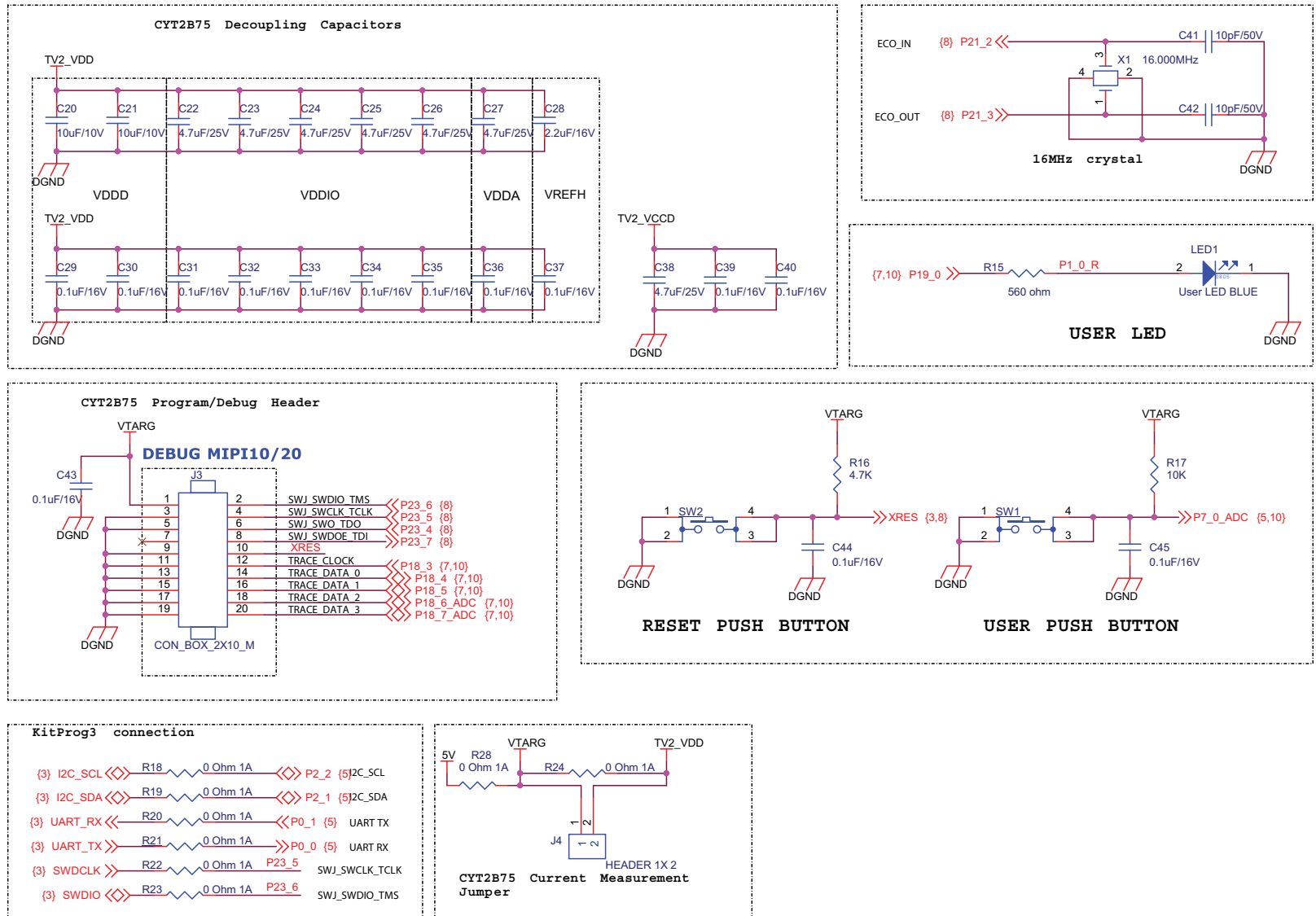

Figure B-4. Schematic (4/10)

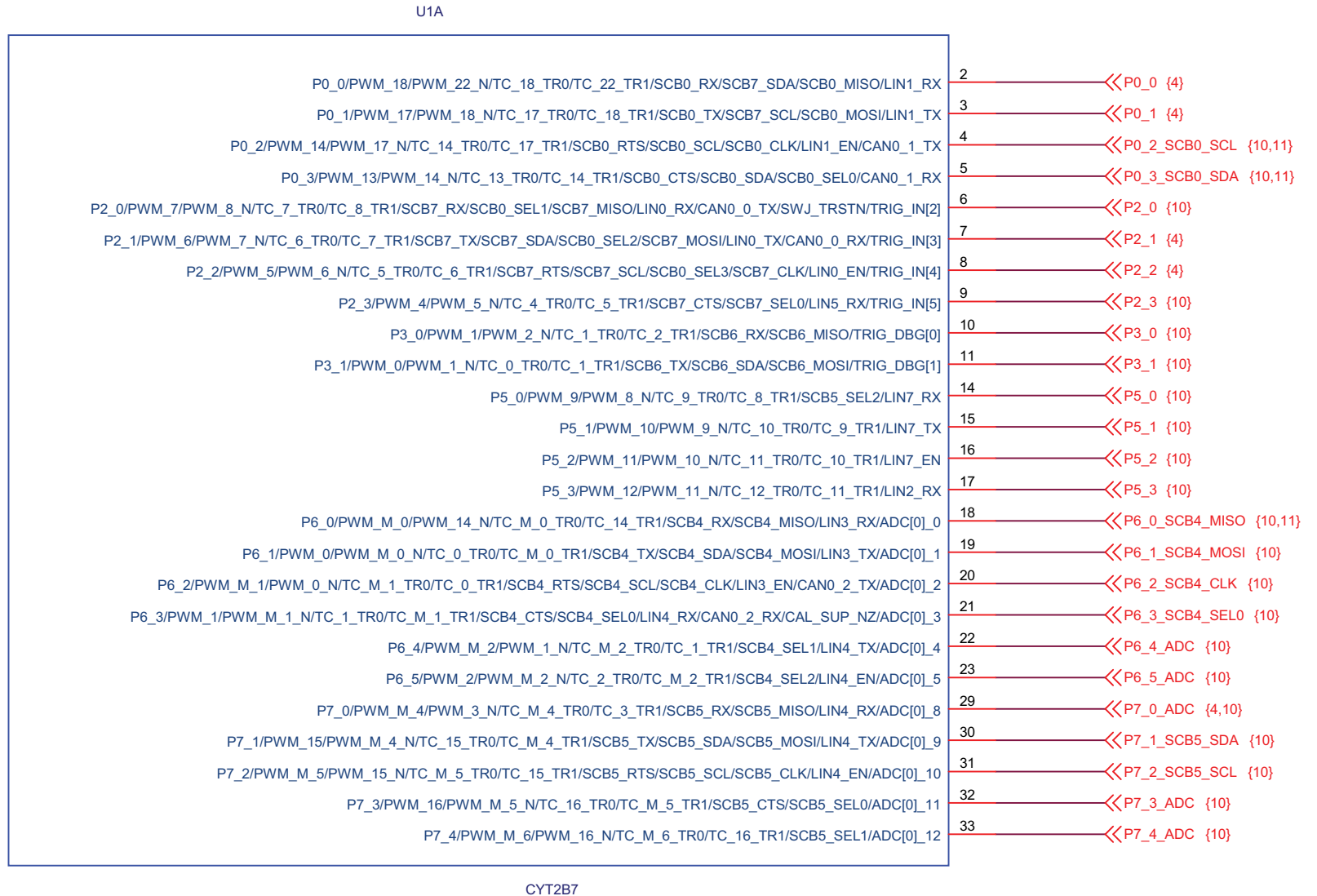

Figure B-5. Schematic (5/10)

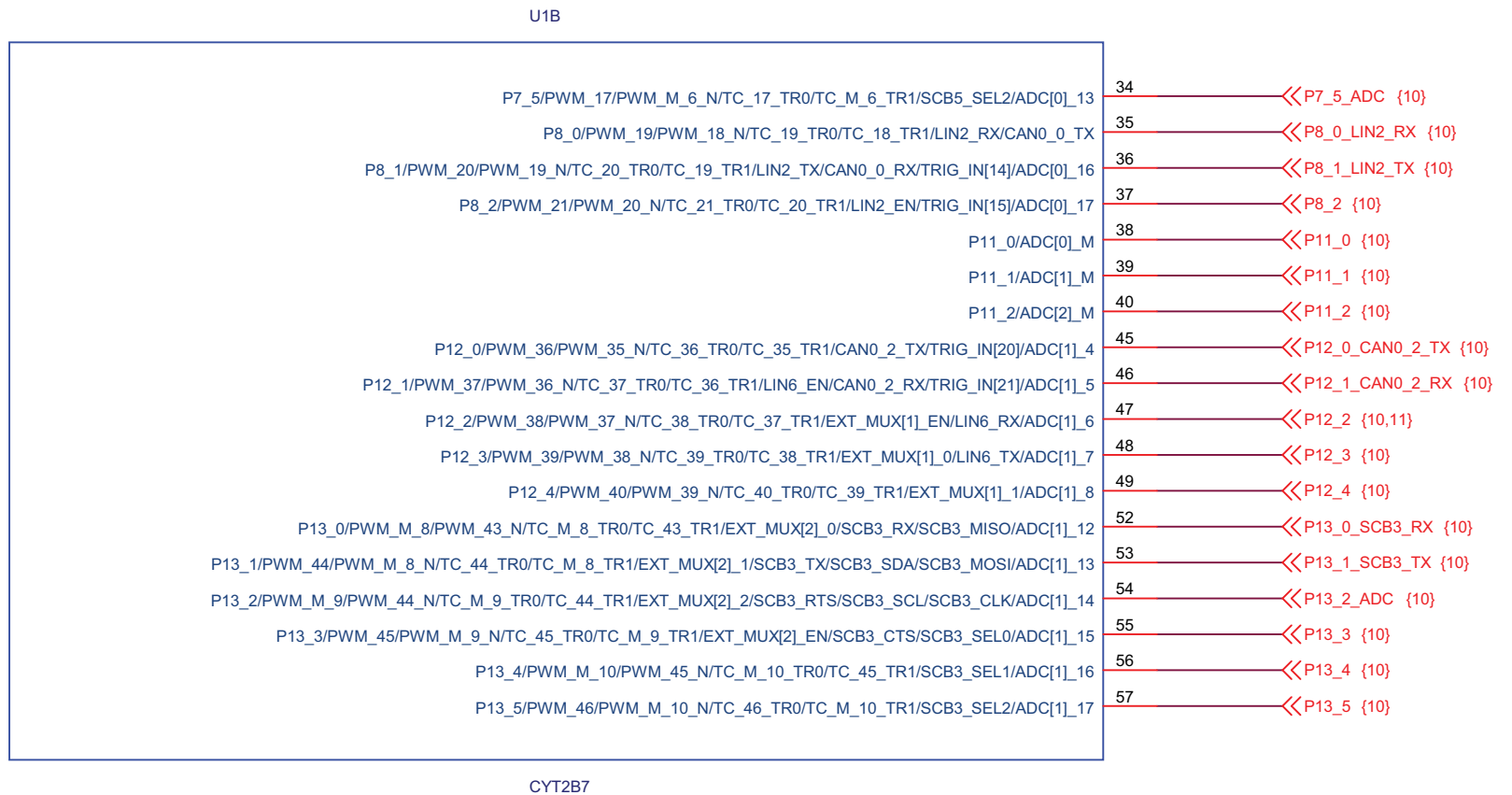

Figure B-6. Schematic (6/10)

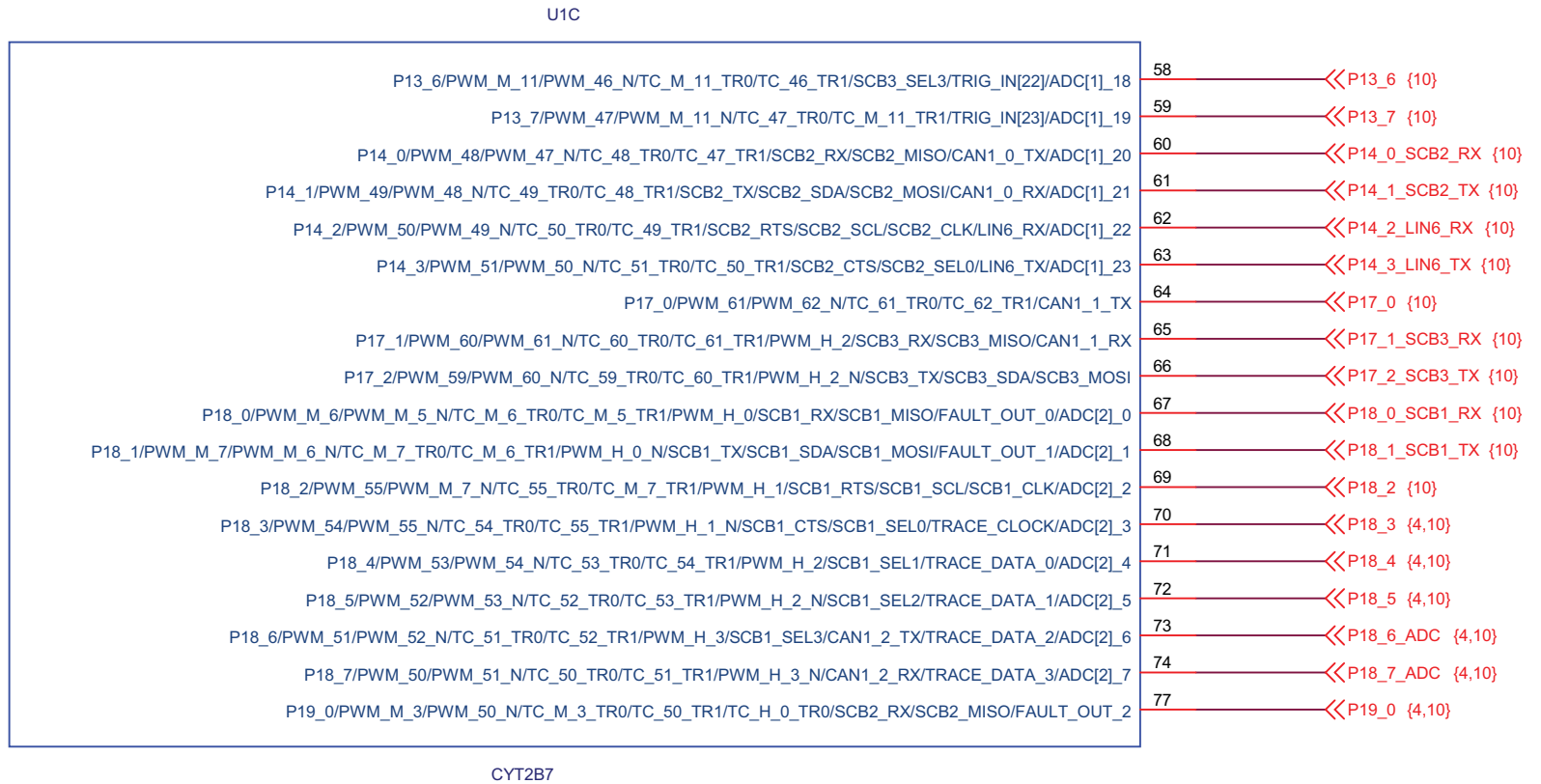



Figure B-7. Schematic (7/10)

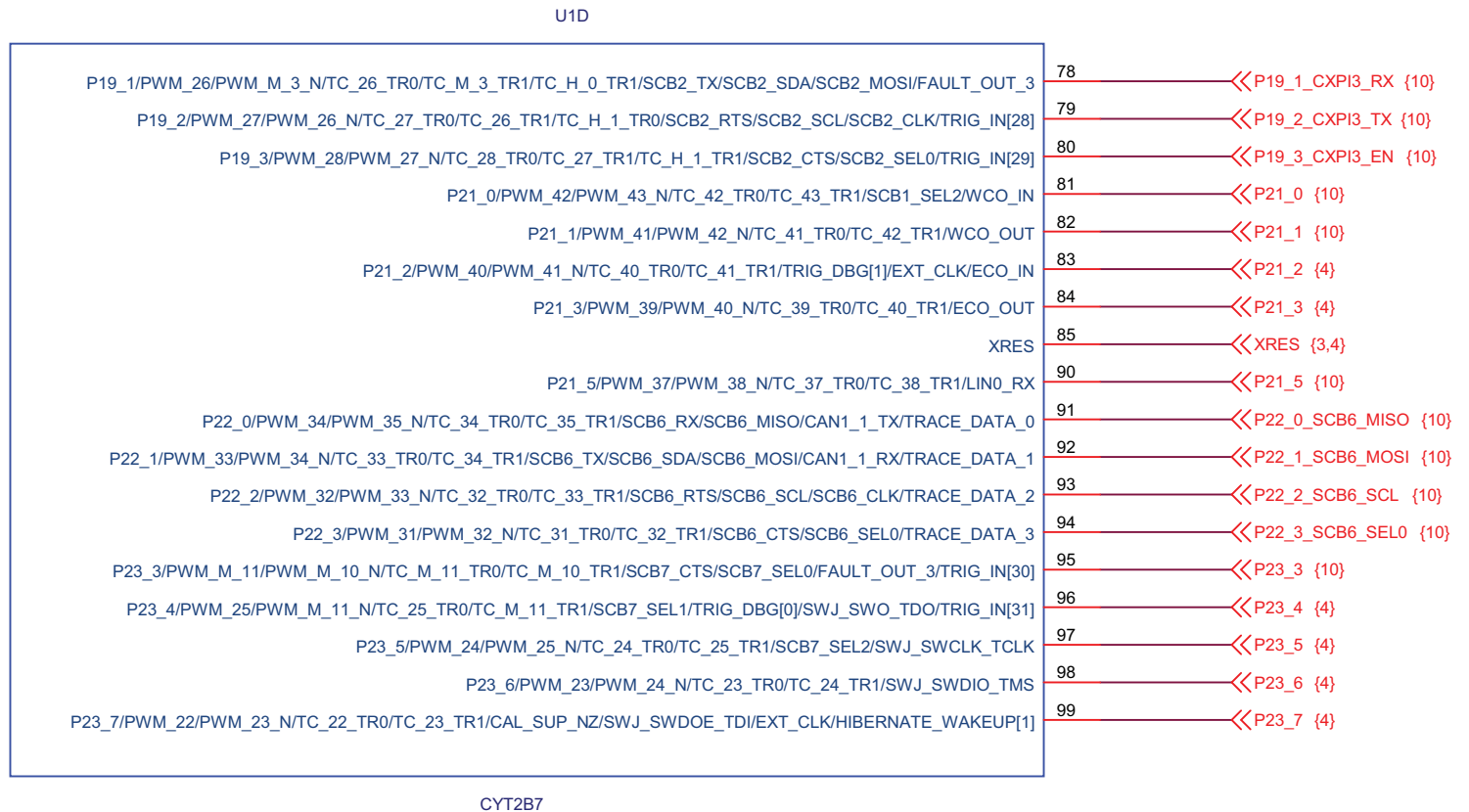

Figure B-8. Schematic (8/10)

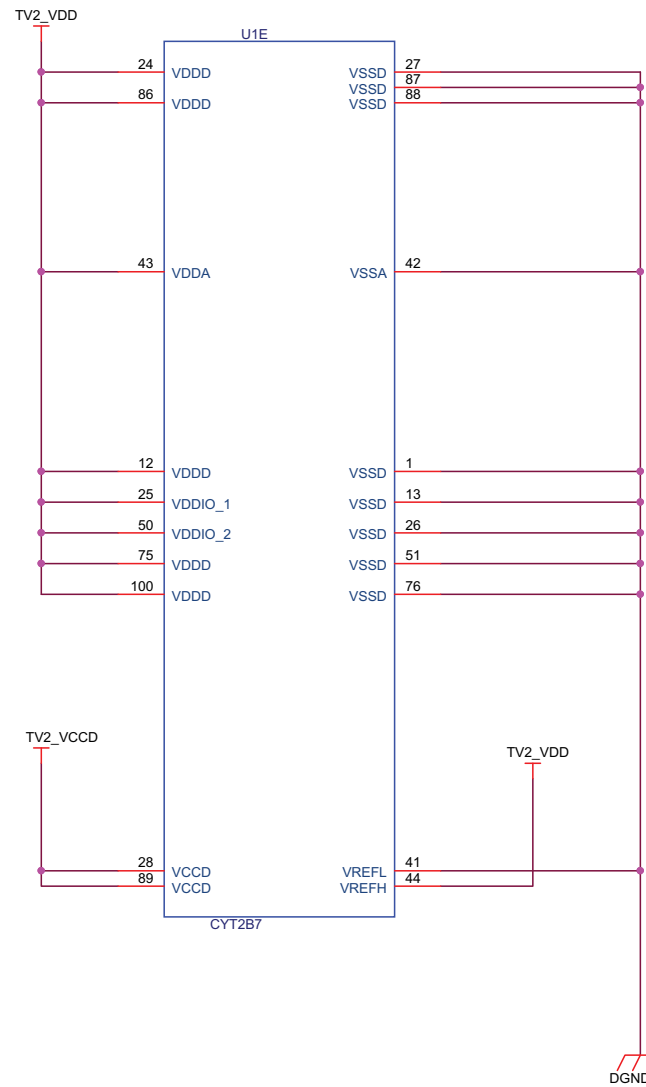

Figure B-9. Schematic (9/10)

Target Device

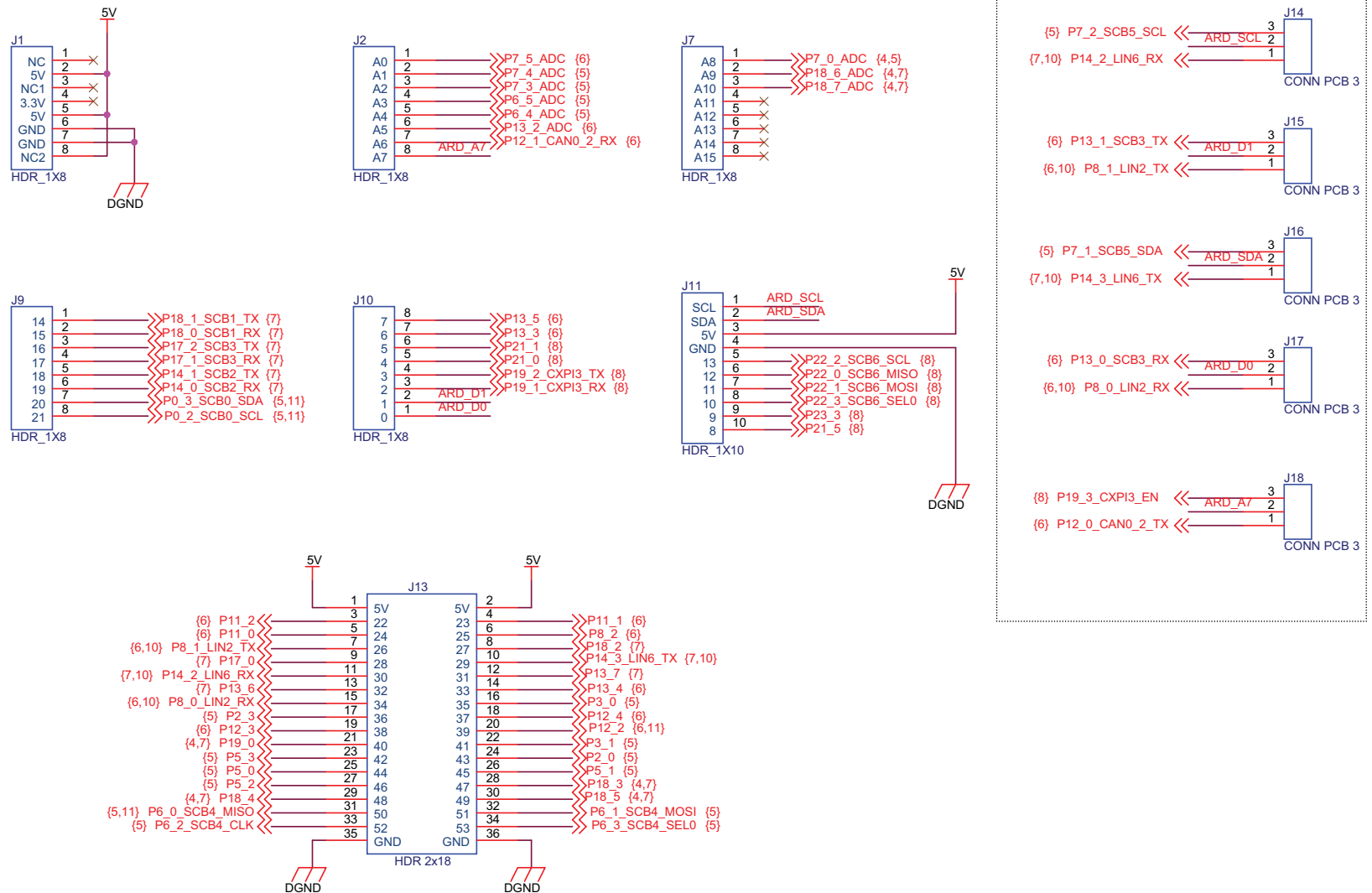
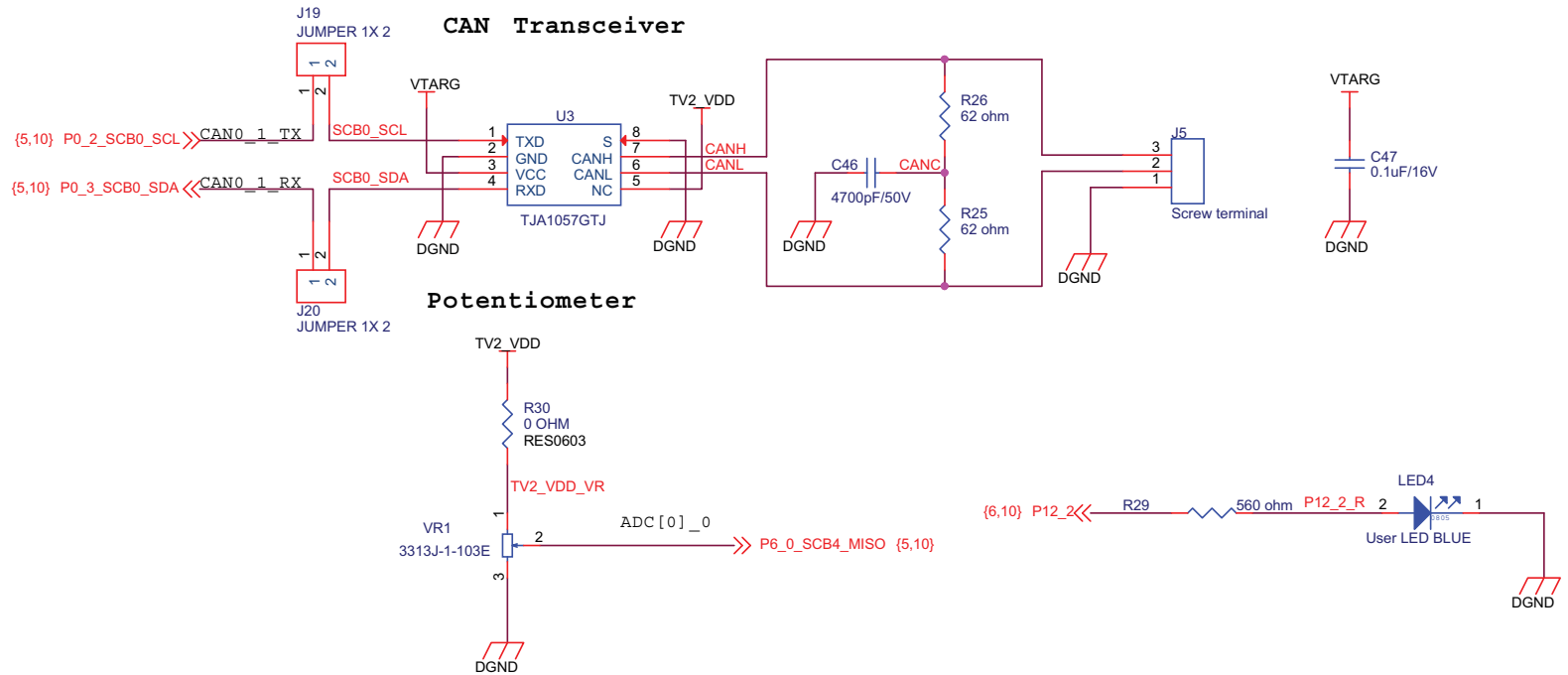

Figure B-10. Schematic (10/10)

**CANFD, Potentiometer**



## B.2 Layouts

Figure B-11. Layout (Top View)

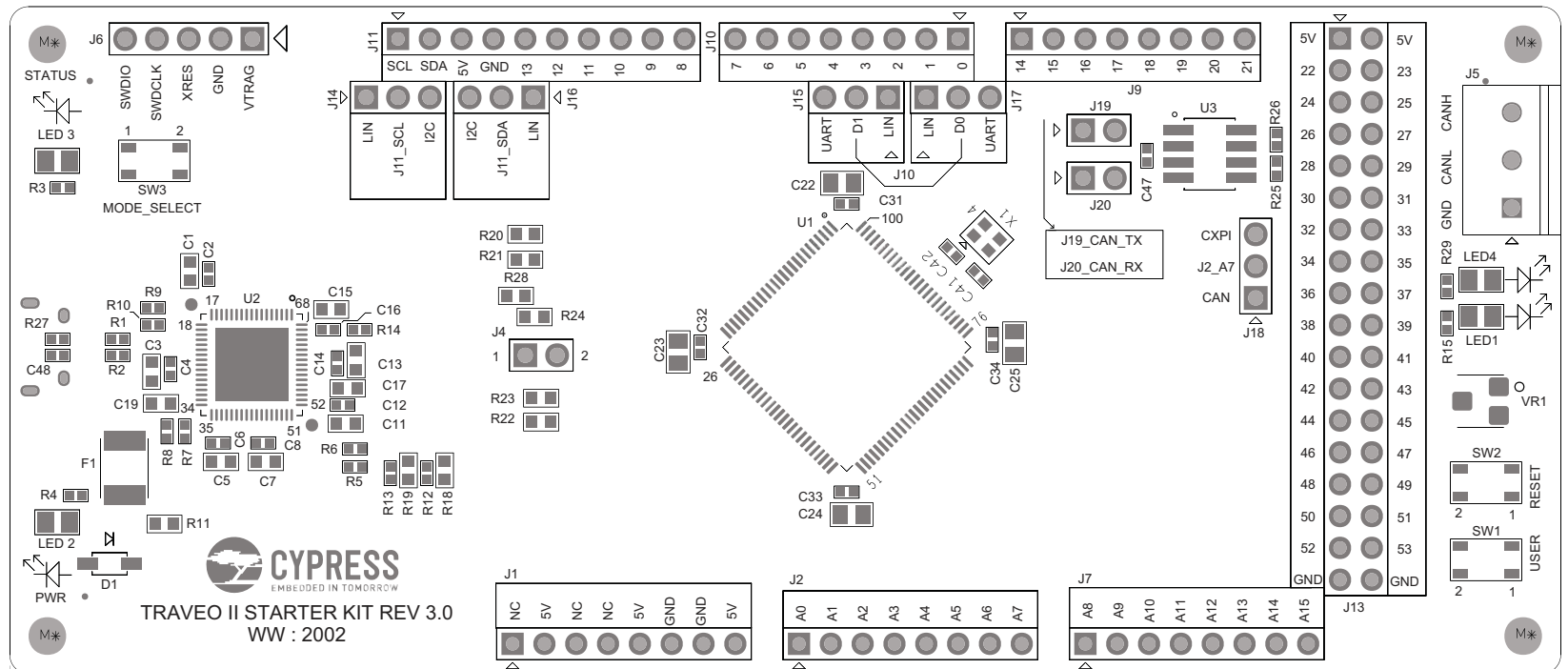

PRIMARY ASSEMBLY

Figure B-12. Layout (Bottom View)

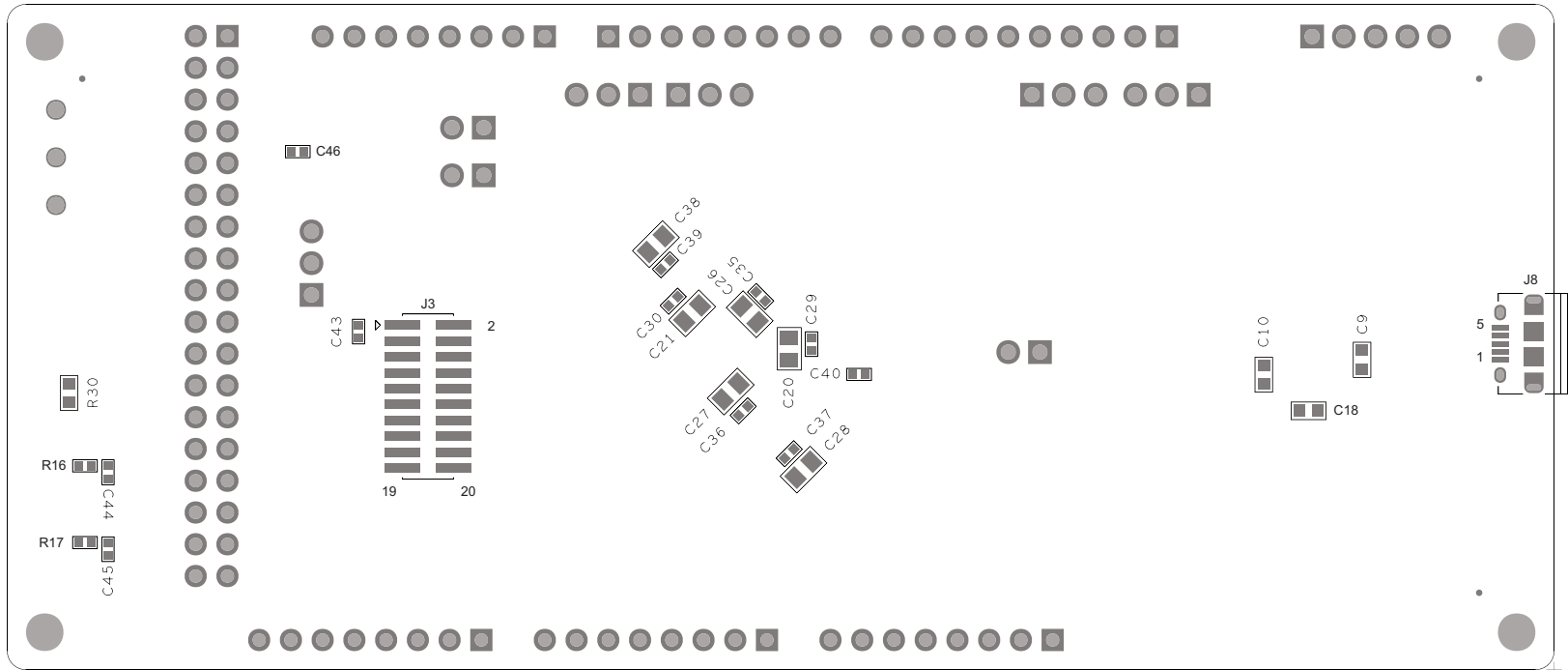

## SECONDARY ASSEMBLY

# Revision History



## Document Revision History

Document Title: Traveo II Starter Kit User Guide			
Document Number: 002-25314			
Revision	ECN#	Issue Date	Description of Change
**	6351876	10/16/2018	New User Guide
*A	6934769	07/27/2020	Added Note in Introduction. Replaced <a href="#">Figure 2-1</a> and <a href="#">Figure 2-2</a> . Revised <a href="#">Table 2-1</a> . Removed 2.1.1. Block Diagram because it is same as <a href="#">2.1 Functional Overview</a> . Replaced <a href="#">Figure 3-1</a> to <a href="#">Figure 3-8</a> . Revised <a href="#">Table 3-1</a> , <a href="#">Table 3-3</a> , and <a href="#">Table 3-5</a> . Changed Section <a href="#">3.8 Arduino Compatible Pin Headers</a> . Revised Section <a href="#">3.9 Debug Interface (Optional)</a> . Revised <a href="#">Table A-1</a> . Added Section <a href="#">A.1.4 MODE SW</a> . Replaced from "Figure B-1 to B-4" to " <a href="#">Figure B-1 to Figure B-10</a> ". Replaced from "Figure B-5 to B-6" to " <a href="#">Figure B-11 to Figure B-12</a> ".
*B	6967760	09/18/2020	Renamed "CYTVII-B-E-1M-SK Evaluation Board" to "Traveo II Starter Kit".