

PD-IM-7604-4M/T4H

User Guide

**PD-IM-7604-4MH and PD-IM-7604-4T4H Four 2-Pair Ports
and Four 4-Pair Ports Evaluation Boards**

June 2019



a  MICROCHIP company

Contents

1	Revision History	1
1.1	Revision 2.0	1
1.2	Revision 1.0	1
2	Product Overview	2
2.1	Evaluation System Features	4
2.2	Evaluation System Interfaces and Connections	4
2.2.1	RJ45 Connectors	5
2.2.2	V IN Connector	6
2.2.3	Isolated USB Interface	6
2.3	Test Points	7
2.4	LED Indication	7
2.5	Physical Characteristics	8
2.6	Electrical Characteristics	8
3	Installation and Settings	9
3.1	Initial Configuration	9
4	Reference Documents	11
5	Ordering Information	12

1 Revision History

The revision history describes the changes that were implemented in the document. The changes are listed by revision, starting with the most current publication.

1.1 Revision 2.0

Revision 2.0 was published in June 2019 with minor editorial corrections.

1.2 Revision 1.0

Revision 1.0 was first published in November 2017. It was the first publication of this document.

2 Product Overview

The PD-IM-7604-4M/T4H evaluation board is developed based on two PD69208M/PD69208T4-PD69204T4 and PD69200 chipsets, and demonstrates the operation of four 4-pair ports and four 2-pair ports systems.

Microsemi's PD69208M/PD69208T4/PD69204T4 Power over Ethernet (PoE) manager IC integrates power, analog, and state-of-the-art logic into a single 56-pin, plastic QFN package. The device is used in Ethernet switches and midspans to allow network devices to share power and data over the same cable. The PD69208M/PD69208T4 device is an 8-port and PD69204T4 device is a 4-port, mixed-signal, and high-voltage PoE driver. With the PD69200 external MCU, it performs as a PSE system. Microsemi's PD69200 PoE controller is a cost-effective and pre-programmed MCU designed to implement enhanced mode.

The PD69208M/PD69208T4/PD69204T4 and PD69200 chipset supports PoE powered device (PD) detection, power-up, and protection according to IEEE standards as well as legacy/pre-standard PD detection. It provides real-time PD protection through the following mechanisms such as, overload, under-load, over-voltage, over-temperature, and short-circuit, and enables operation in a standalone mode. It also executes all real-time functions as specified in IEEE 802.3at and IEEE 802.3bt draft 3.0 standards, including PD detection (AF and AT).

PD69208M/PD69208T4/PD69204T4 supports supply voltages between 32 V and 57 V without additional power sources. A system that powers over four pairs can be implemented by combining 2 ports of PD69208M/T4 and PD69204T4, enabling an extra feature for simple and low-cost high-power PD devices. Ongoing monitoring of system parameters for the host software is available through communication. Internal thermal protection is implemented in the chip. The PD69208M/PD69208T4/PD69204T4 is a low power dissipation device that uses internal MOSFETs and internal 100 m Ω sense resistors.

The PD69200 features an ESPI bus for each PD69208M/PD69208T4/PD69204T4. It is based on Freescale's Kinetis_L family MKL15Z128VFM4 embedded with an ARM Cortex™-M0+core. The PD69200 utilizes an I²C or UART interface to the host CPU. It is designed to support software field-upgradable through the communication interface.

The evaluation system provides designers with the required environment to evaluate the performance and implementation of the following.

- PD69204T4 (four ports) and PD69208T4 (eight ports) PoE managers and PD69200 PoE controller (in board PD-IM-7604-4T4H)
- PD69208M (eight ports) PoE manager and PD69200 PoE controller (in board PD-IM-7604-4MH)

The evaluation board, shown in the following figure, enables PoE designers to evaluate Microsemi's PoE solution with flexibility and easy configuration. The application circuit of two PD69208M/PD69208T4-PD69204T4 and PD69200 chipset is compact in size (highlighted in the white box on board).

Figure 1 • PD-IM-7604-4M/T4H Evaluation System Block Diagram

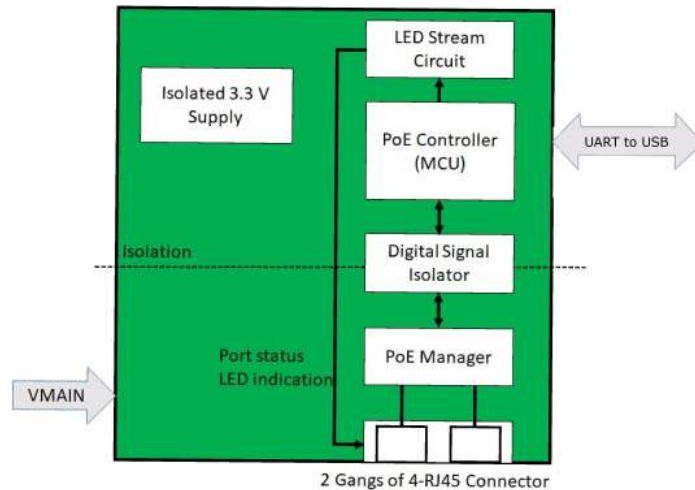

Input supply to the board is DC and it can be fed through the V_{IN} connector (see [Electrical Characteristics \(see page 8\)](#) for the input voltage range). The auxiliary power supply (5 V and 3.3 V) for the PD69208M/PD69208T4/PD69204T4 is generated internally and the auxiliary power supply (3.3 V) for the PD69200 MCU is generated using a 3.3 V isolated DC – DC converter.

The board communicates with the host environment using UART communication, available through a USB connector (U11). For this connection, a driver for CP210x should be installed. The driver can be downloaded from <http://www.silabs.com/products/mcu/Pages/USBtoUARTBridgeVCPDrivers.aspx>.

A dedicated reset push button (SW1) is provided for resetting the PoE controller. The board consists of eight output ports, of which four are 2-pair ports and the remaining four are 4-pair ports.

The board consists of different test points (for more information, see [Test Points \(see page 7\)](#)). The board also provides different LED indications (for more information, see [LED Indication \(see page 7\)](#)).

The following figure shows a top view of the evaluation board.

Figure 2 • PD-IM-7604-4M/T4H Evaluation Board

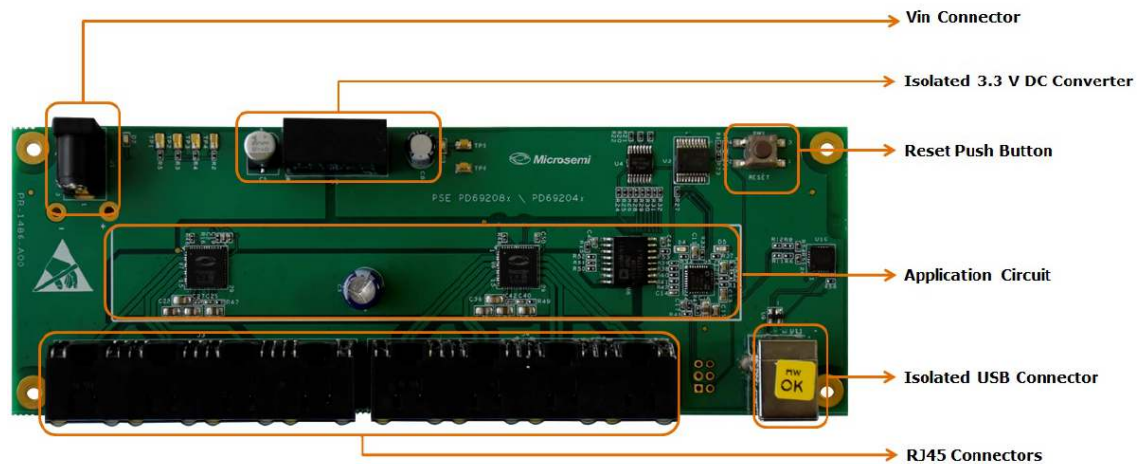

2.1 Evaluation System Features

The evaluation system has the following features.

- Two gangs (each contains four RJ45 connectors)
- Switch domain isolated from PoE domain
- Switch domain USB interface
- PoE controller manual reset
- LED status indication for all the ports (LED stream)
- Requires single power source only
- 0 °C to 40 °C working temperature
- RoHS compliant

2.2 Evaluation System Interfaces and Connections

The evaluation system interfaces and connectors are listed in the following table.

Table 1 • Evaluation board Connectors

Serial Number	Connector	Name	Description
1	J3, J4	RJ45	Eight RJ45 ports are connected to the powered device load connectors
2	J1	V _{IN} connector	The DC in (V _{MAIN}) connection is used to power the evaluation board
3	U11	Isolated USB	The USB communication, coming from the hosting system (U11), converted to UART and directed to the PoE controller

2.2.1 RJ45 Connectors

There are two dedicated RJ45 connectors. Each contains four RJ45 ports, so there are eight ports in total. The four ports of J3 are 2-pair ports (port numbers 0, 1, 2, and 3) and the power connections of the port are listed in the following table.

Table 2 • RJ45 Connectors 2-pair Port

Pin Number (each RJ45)	Signal Name	Description
4, 5	SPARE - Vport_Pos	PoE's positive spare port
7, 8	SPARE - Vport_Neg	PoE's negative spare port

The four ports of J4 are 4-pair ports (port numbers 4, 5, 6, and 7) and the power connections of the port are listed in the following table.

Table 3 • RJ45 Connectors 4-pair Port

Pin Number (each RJ45)	Signal Name	Description
1, 2	DATA - Vport_Neg	PoE's negative data port
3, 6	DATA - Vport_Pos	PoE's positive data port
4, 5	SPARE - Vport_Pos	PoE's positive spare port
7, 8	SPARE - Vport_Neg	PoE's negative spare port

- Manufacturer: Amphenol
- Manufacturer part number: RJHSE508104

The following figure shows the RJ45 connectors.

Figure 3 • RJ45 Connectors

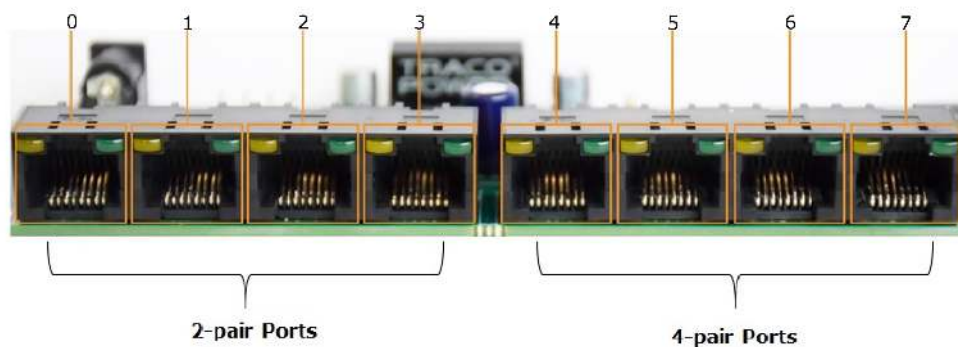

2.2.2 V IN Connector

The DC input (V_{MAIN}) connection is used for powering the evaluation system. The recommended input voltage range is $44 \text{ V DC} > V_{\text{MAIN}} > 57 \text{ V DC}$. The input connector is rated for 5 A (See [Evaluation Board](#) for the V_{IN} connector).

Table 4 • V IN Connector

Pin Number	Signal Name	Description
1	V_{MAIN}	Main positive voltage (referenced to GND_ANALOG)
2	GND_ANALOG	Analog ground
3	GND_ANALOG	Analog ground

- Manufacturer: SWITCHCRAFT
- Manufacturer part number: RAPC722X

The polarity of the V_{IN} connector is as shown in the following figure.

Figure 4 • Power Supply Cable Polarity



2.2.3 Isolated USB Interface

This interface supplies USB communication coming from the hosting system (U11), converted to UART communication (See [Evaluation Board](#) for the isolated USB connector).

Table 5 • Isolated USB Interface

Pin Number	Signal Name	Description
1	VBUS	Voltage supply from USB bus
2	D-	Dedicated USB signal
3	D+	Dedicated USB signal
4	GND_F	Floating ground

- Manufacturer: Samtec
- Manufacture part number: USB-B-S-S-B-TH

2.3 Test Points

The following table lists the test points in the evaluation board.

Table 6 • Test Points

Designation	Description
TP1	Connected to power good pin, PG3
TP2	Connected to power good pin, PG2
TP3	Connected to power good pin, PG1
TP4	Connected to power good pin, PG0
TP5	PD69200 supply (3.3 V) test point
TP6	PD69200 ground test point
TP7	I ² C bus serial data (SDA)
TP8	I ² C bus serial clock (SCL)
h1 (+)	Evaluation board positive input (V _{MAIN}) test point
h2 (-)	Evaluation board input ground test point

2.4 LED Indication

The evaluation board contains status indication LEDs, listed in the following table.

Table 7 • LED Indication

Designation	Description
D2	Input voltage indication
D3	PoE controller 3.3 V indication
D4	System OK indication; by default, turns on when input voltage is within operating range
D5	Interrupt indication; LED turns on when a pre-configured event is happening

Apart from these LEDs, each RJ45 connector port contains a dedicated LED (green LED), which displays the status of the particular port.

Table 8 • Port Status Indications

Port LED Color	Port Load Conditions	Port Voltage
Off	Inactive load or unplugged load	Power to port is disconnected, no DC voltage is present on port output lines
Green	Active load is plugged in and complies with normal load conditions	Continuous nominal DC voltage is present
Blinking green	Overload, short circuit, or power management	Power to port is disconnected, no DC voltage is present on port output lines

2.5 Physical Characteristics

The mechanical dimensions of the board are 180 mm × 60 mm × 16 mm (L × W × H).

2.6 Electrical Characteristics

The following table lists the electrical characteristics of the evaluation system.

Table 9 • Electrical Characteristics

Parameter	Minimum	Maximum	Units
Main DC supply V_{MAIN}	44	57	V

3 Installation and Settings

This section describes the steps required for installing and operating the PD-IM-7604-4M/T4H evaluation system. Take the following precautions before starting the installation.

- Ensure that the power supply of the board is turned on before the peripheral devices are turned on.
- Ensure that all the required peripherals are connected before powering the board.
- Ensure that power bank15 is set to 200 W.
- Ensure the correct polarity of the power supply cable. The polarity of the power supply cable is as shown in [Power Supply Cable Polarity \(see page 6\)](#).



Note

Confirm that the evaluation board is properly configured prior to starting any operation. For more information about the software and GUI used for enhanced mode operation, see [Software GUI User Guide](#), catalog number 06-0027-056.

3.1 Initial Configuration

The board based on PD69208T4 and PD69204T4 devices (ordering part number PD-IM-7604-4T4H) is configured with the following matrix.

Table 10 • Port Matrix

Port Identification Number	Logical Port	Physical Port (ALT-A)	Physical Port (ALT-B)
0	0	0	255
1	1	1	255
2	2	2	255
3	3	3	255
4	4	4	5
5	5	6	7
6	6	8	9
7	7	10	11

The board based on two PD69208M devices (ordering part number PD-IM-7604-4MH) is configured with the following matrix.

Table 11 • Port Matrix

Port Identification Number	Logical Port	Physical Port (ALT-A)	Physical Port (ALT-B)
0	0	0	255
1	1	1	255
2	2	2	255
3	3	3	255
4	4	8	9
5	5	10	11
6	6	12	13
7	7	14	15

4 Reference Documents

The following documents can be obtained through Microsemi customer support. To access other documents, visit the [Microsemi website](#).

- IEEE 802.3af-2003 Standard, DTE Power via MDI
- IEEE 802.3at-2009 Standard, DTE Power via MDI
- PD69204T4 Datasheet (PD-000303601)
- PD69208M Datasheet (PD-000303451)
- PD69208T4 Datasheet (PD-000303603)
- Application Note 211: Designing a PD69208 48-port Enhanced PoE Systems and Layout Design Guidelines (catalog number PD69208_AN_211) (PD-000300282)
- Technical Note 218: Interfacing LED Stream circuit with PD69200 (catalog number PD69200_TN_218_PoE_LED_Stream_Interface)
- PD69200 Serial Communication Protocol User Guide (catalog number PD_69200_UG_COMM_PROT)
- Software GUI User Guide (catalog number 06-0027-056)

5 Ordering Information

The following table lists the ordering information for the PD-IM-7604-4MH/4T4H evaluation boards.

Table 12 • Ordering information

Ordering Number	Description
PD-IM-7604-4MH	Four 2-pair and four 4-pair type-3 ports, the PD69208M-based enhanced evaluation board supports up to 60 W (4-pair) with LED stream and is RoHS compliant.
PD-IM-7604-4T4H	Four 2-pair and four 4-pair type-4 ports, the PD69208T4/PD69204T4-based enhanced evaluation board supports up to 99 W (4-pair) with LED stream and is RoHS compliant.



Microsemi Headquarters

One Enterprise, Aliso Viejo,
CA 92656 USA

Within the USA: +1 (800) 713-4113

Outside the USA: +1 (949) 380-6100

Sales: +1 (949) 380-6136

Fax: +1 (949) 215-4996

Email: sales.support@microsemi.com

www.microsemi.com

© 2019 Microsemi. All rights reserved. Microsemi and the Microsemi logo are trademarks of Microsemi Corporation. All other trademarks and service marks are the property of their respective owners.

Microsemi makes no warranty, representation, or guarantee regarding the information contained herein or the suitability of its products and services for any particular purpose, nor does Microsemi assume any liability whatsoever arising out of the application or use of any product or circuit. The products sold hereunder and any other products sold by Microsemi have been subject to limited testing and should not be used in conjunction with mission-critical equipment or applications. Any performance specifications are believed to be reliable but are not verified, and Buyer must conduct and complete all performance and other testing of the products, alone and together with, or installed in, any end-products. Buyer shall not rely on any data and performance specifications or parameters provided by Microsemi. It is the Buyer's responsibility to independently determine suitability of any products and to test and verify the same. The information provided by Microsemi hereunder is provided "as is, where is" and with all faults, and the entire risk associated with such information is entirely with the Buyer. Microsemi does not grant, explicitly or implicitly, to any party any patent rights, licenses, or any other IP rights, whether with regard to such information itself or anything described by such information. Information provided in this document is proprietary to Microsemi, and Microsemi reserves the right to make any changes to the information in this document or to any products and services at any time without notice.

Microsemi, a wholly owned subsidiary of Microchip Technology Inc. (Nasdaq: MCHP), offers a comprehensive portfolio of semiconductor and system solutions for aerospace & defense, communications, data center and industrial markets. Products include high-performance and radiation-hardened analog mixed-signal integrated circuits, FPGAs, SoCs and ASICs; power management products; timing and synchronization devices and precise time solutions; setting the world's standard for time; voice processing devices; RF solutions; discrete components; enterprise storage and communication solutions; security technologies and scalable anti-tamper products; Ethernet solutions; Power-over-Ethernet ICs and midspans; as well as custom design capabilities and services. Microsemi is headquartered in Aliso Viejo, California, and has approximately 4,800 employees globally. Learn more at www.microsemi.com.

PD-000354473