

LOC	DIST	P	F	ZONE	LTR	REVISIONS	DATE	APPD
BD	39				F	REVISED & REDRAWN PER ECN 2364	9/15/88	gtb

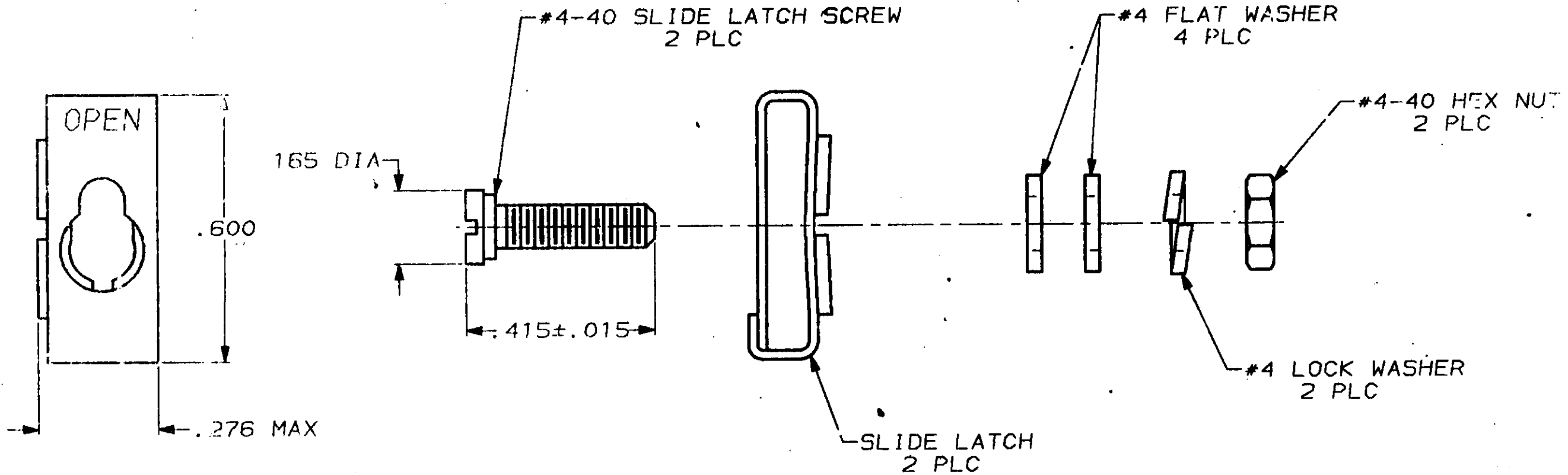

- 1. PARTS PACKAGED UNASSEMBLED.
- 2. PARTS PACKAGED AS A UNIT KIT.
- 3. PARTS INDIVIDUALLY BULK PACKED & SHIPPED AS A UNIT PACKAGE.
- 4. ZINC PLATED PER ASTM B633, TYPE II, CLASS SCI, YELLOW CHROMATE.
- 5. ZINC PLATED PER ASTM B633, TYPE III, CLASS SCI, CLEAR CHROMATE.
- 6. THIS KIT CAN BE USED WITH ONE-PIECE STRAIGHT/45° EXIT CABLE CLAMPS, ONE-PIECE STRAIGHT/90° EXIT CABLE CLAMPS, OR ON CONNECTORS WITHOUT CABLE CLAMPS.

6	OBSOLETE	5	#4-40	3	206942-4
6	OBSOLETE	5	#4-40	2	206942-3
6		4	#4-40	3	206942-2
6		4	#4-40	2	206942-1

DO NOT SCALE PRINT. UNLESS SPECIFIED DIMENSIONS IN INCHES TOLERANCES ON:		AMP INCORPORATED Morgantown, Pa. 17105	
MATERIAL	SLIDE LATCH, STAINLESS STEEL	NAME	KIT, TWO-PIECE SLIDE LATCH, SIZES 1 THRU 4, AMPLIMITE®
HARDWARE	STEEL PER ASTM A108	SIZE	B
FINISH	HARDWARE, SEE TABLE	F SCH NO	00779
		DRAWING NO	206942
		SCALE	4:1
		SHEET	1 OF 1