



**Please note that Cypress is an Infineon Technologies Company.**

The document following this cover page is marked as “Cypress” document as this is the company that originally developed the product. Please note that Infineon will continue to offer the product to new and existing customers as part of the Infineon product portfolio.

**Continuity of document content**

The fact that Infineon offers the following product as part of the Infineon product portfolio does not lead to any changes to this document. Future revisions will occur when appropriate, and any changes will be set out on the document history page.

**Continuity of ordering part numbers**

Infineon continues to support existing part numbers. Please continue to use the ordering part numbers listed in the datasheet for ordering.



**AN INFINEON TECHNOLOGIES COMPANY**

**THIS SPEC IS OBSOLETE**

Spec No: 002-08501

Spec Title: S6AE102A/S6AE103A ENERGY HARVESTING PMIC  
FOR WIRELESS SENSOR NODE

Replaced by: NONE

# Energy Harvesting PMIC for Wireless Sensor Node

The S6AE102A/103A is a power management IC (PMIC) for energy harvesting that is built into circuits of solar cells connected in series, dual output power control circuits, output capacitor storage circuits, power switching circuits of primary batteries, a LDO, a comparator and timers. Super-low-power operation is possible using a consumption current of only 280 nA and startup power of only 1.2  $\mu$ W. As a result, even slight amounts of power generation can be obtained from compact solar cells under low-brightness environments of approximately 100 lx. This IC stores power generated by solar cells to an output capacitor using built-in switch control, and it turns on the power switching circuit while the capacitor voltage is within a preset maximum and minimum range for supplying energy to a load. The output power control circuit has 2 outputs, and 1 of 2 outputs can control On and OFF of the power gating circuit using interrupt signal. The output capacitor storage circuits have 2 capacitor connection circuit for a storage of system load and a storage of surplus power, and if the power generated from solar cells is enough, the power is stored to the capacitor of surplus power storage. If the power generated from solar cells is not enough, energy can also be supplied in the same way as solar cells from the capacitor of surplus power storage or connected primary batteries for auxiliary power. This IC has also an independent LDO. The LDO can provide stable voltage that a sensor requires. And also an independent comparator which can make voltage comparison signal output a lot of flexibility is built in. Also, an over voltage protection (OVP) function is built into the input pins of the solar cells, and the open voltage of solar cells is used by this IC to prevent an over voltage state. The S6AE102A/103A is provided as a battery-free wireless sensor node solution that is operable by super-compact solar cells or non-disconnect energy harvesting based wireless sensor node solution with the capacitor of surplus storage or primary batteries for auxiliary power.

## Features

- Operation input voltage range
  - Solar cell power : 2.0V to 5.5 V
  - Primary battery power : 2.0V to 5.5 V
- Adjustable output voltage range : 1.1V to 5.2V
- Low-consumption current : 280 nA
- Minimum input power at startup : 1.2  $\mu$ W
- Low-consumption current LDO : 400 nA
- Low-consumption current Timer : 30 nA
- Low-consumption current comparator : 20 nA (S6AE103A only)
- Hybrid control of solar cell and primary battery with power path control
- Solar powered power control without battery
- System power reduction control with power gating
- Power gating control with interrupt signal
- Power gating control with timer (S6AE103A only)
- Hybrid storage system for a storage of system load and a storage of surplus power
- Power supply and switch control signal output for external path switch control
- Input over voltage protection : 5.4V
- Compact QFN-20/QFN-24 package : 4 mm  $\times$  4 mm

## Applications

- Energy harvesting power system with a very small solar cell
- Bluetooth® Smart sensor
- Wireless HVAC sensor
- Wireless lighting control
- Security system
- Smart home / Building / Industrial wireless sensor

## Block Diagram

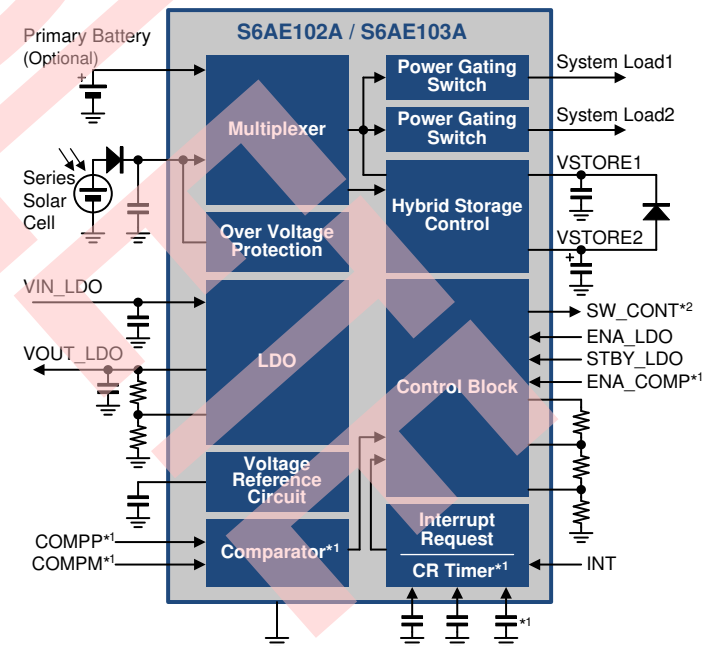

\*1: S6AE103A only \*2: SW\_CONT/COMPOUT for S6AE103A

## Contents

<b>Features</b> .....	<b>1</b>
<b>Applications</b> .....	<b>1</b>
<b>Block Diagram</b> .....	<b>1</b>
<b>1. Product Lineup</b> .....	<b>3</b>
<b>2. Packages</b> .....	<b>3</b>
<b>3. Pin Assignment</b> .....	<b>3</b>
<b>4. Pin Descriptions</b> .....	<b>5</b>
<b>5. Architecture Block Diagram</b> .....	<b>7</b>
<b>6. Absolute Maximum Ratings</b> .....	<b>9</b>
<b>7. Recommended Operating Conditions</b> .....	<b>9</b>
<b>8. Electrical Characteristics</b> .....	<b>10</b>
<b>9. Functional Description</b> .....	<b>13</b>
9.1 Power Supply Control.....	13
9.2 Power Gating.....	23
9.3 Discharge.....	27
9.4 SW_CNT Control.....	27
9.5 General-Purpose Comparator.....	27
9.6 LDO.....	27
9.7 Over Voltage Protection (OVP).....	28
<b>10. Application Circuit Example and Parts list</b> .....	<b>28</b>
<b>11. Application Note</b> .....	<b>30</b>
11.1 Setting the Operation Conditions.....	30
<b>12. Development Support</b> .....	<b>31</b>
<b>13. Reference Data</b> .....	<b>31</b>
<b>14. Usage Precaution</b> .....	<b>33</b>
<b>15. RoHS Compliance Information</b> .....	<b>33</b>
<b>16. Ordering Information</b> .....	<b>33</b>
<b>17. Package Dimensions</b> .....	<b>34</b>
<b>18. Major Changes</b> .....	<b>36</b>
<b>Document History</b> .....	<b>36</b>
<b>Sales, Solutions, and Legal Information</b> .....	<b>37</b>

### 1. Product Lineup

#### Function

Product Name	S6AE102A	S6AE103A
Pin count	20	24
Power supply voltage range	2.0V to 5.5 V	
Output voltage range	1.1V to 5.2V	
Output channel	2ch	
LDO	1ch	
Over voltage protection (OVP)	VDD pin	
Timer	1unit	3units
Comparator	-	1ch

### 2. Packages

Product Name	S6AE102A	S6AE103A
Package		
VNF020	○	-
VNF024	-	○

○: Available

#### Note:

- See "17. Package Dimensions" for detailed information on each package.

### 3. Pin Assignment

Figure 3-1 Pin Assignment of S6AE102A

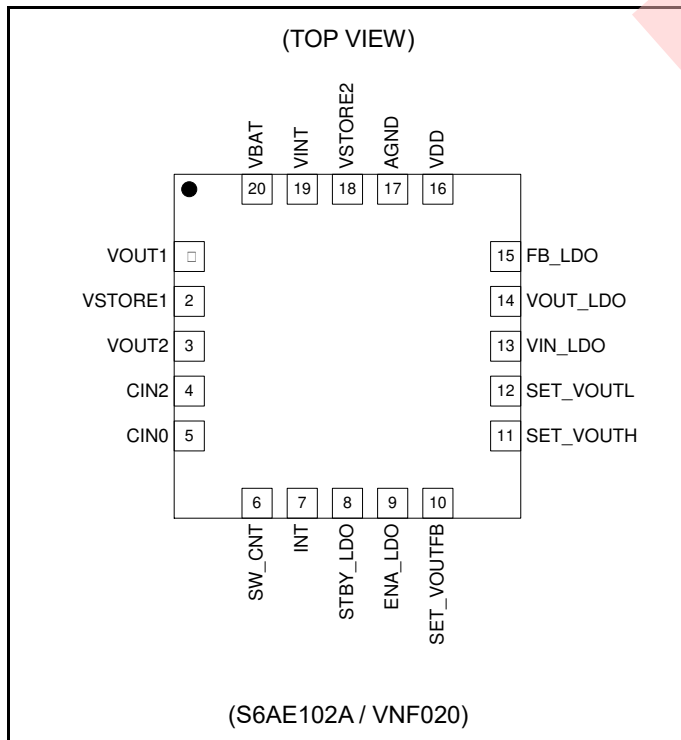
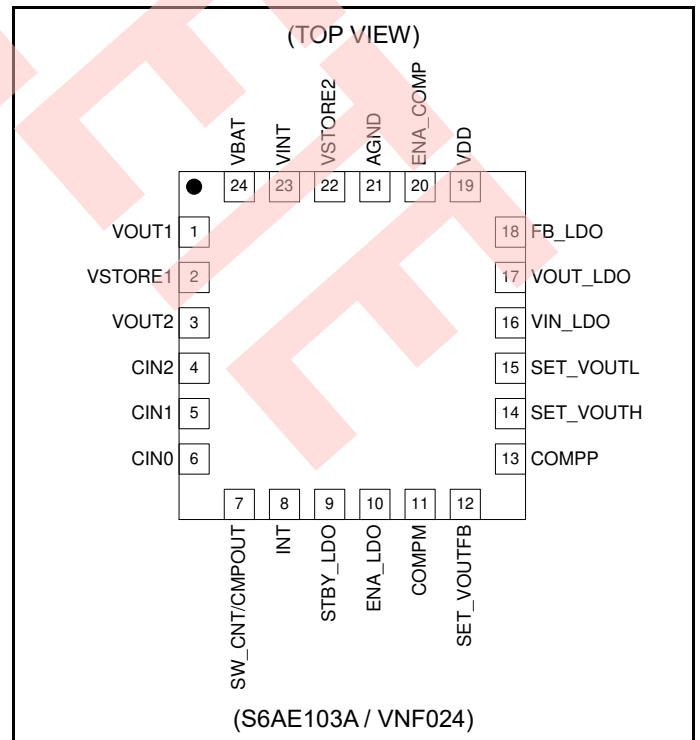

Figure 3-2 Pin Assignment of S6AE103A



OBsolete

## 4. Pin Descriptions

**Table 4-1 Pin Descriptions**

Pin No.		Pin Name	I/O	Description
S6AE102A	S6AE103A			
1	1	VOUT1	O	Output voltage pin
2	2	VSTORE1	O	Storage output pin
3	3	VOUT2	O	Output voltage pin
4	4	CIN2	O	Timer time 2 (T2) setting pin(for connecting capacitor) For the pin setting, refer to "Table 9-2 Power Gating Operation Mode"
-	5	CIN1	O	Timer time 1 (T1) setting pin(for connecting capacitor) For the pin setting, refer to "Table 9-2 Power Gating Operation Mode"
5	6	CIN0	O	Timer time 0 (T0) setting pin(for connecting capacitor) For the pin setting, refer to "Table 9-2 Power Gating Operation Mode"
-	7	SW_CNT/COMPOUT	O	VOUT1 switch interlocking output pin / Comparator output pin
6	-	SW_CNT	O	VOUT1 switch interlocking output pin
7	8	INT	I	Event driven mode control pin For the pin setting, refer to "Table 9-2 Power Gating Operation Mode" (when being not used, connect this pin to AGND )
8	9	STBY_LDO	I	LDO operation mode setting pin For the pin setting, refer to "Table 9-4 LDO Operation Mode" (when being not used, connect this pin to AGND )
9	10	ENA_LDO	I	LDO output control pin For the pin setting, refer to "Table 9-4 LDO Operation Mode" (when being not used, connect this pin to AGND )
-	11	COMPM	I	Comparator Input pin (when being not used, leave this pin open )
10	12	SET_VOUTFB	O	Reference voltage output pin (for connecting resistor)
-	13	COMPP	I	Comparator input pin (when being not used, leave this pin open )
11	14	SET_VOUTH	I	VOUT1, VOUT2 output voltage setting pin (for connecting resistor)
12	15	SET_VOUTL	I	VOUT1, VOUT2 output voltage setting pin (for connecting resistor)
13	16	VIN_LDO	I	LDO power input pin (when being not used, connect this pin to AGND )
14	17	VOUT_LDO	O	LDO output pin
15	18	FB_LDO	I	LDO output voltage setting pin (for connecting resistor) (when being not used, leave this pin open )
16	19	VDD	I	Solar cell input pin (when being not used, leave this pin open )
-	20	ENA_COMP	I	Comparator control pin For the pin setting, refer to "9.5 General-Purpose Comparator" (when being not used, connect this pin to AGND )
17	21	AGND	-	Ground pin
18	22	VSTORE2	O	Storage output pin (Supplying power to VSTORE1 pin via an external diode)
19	23	VINT	O	Internal circuit storage output pin
20	24	VBAT	I	Primary battery input pin (when being not used, leave this pin open )

Figure 4-1 S6AE102A / S6AE103A I/O Pin Equivalent Circuit Diagram

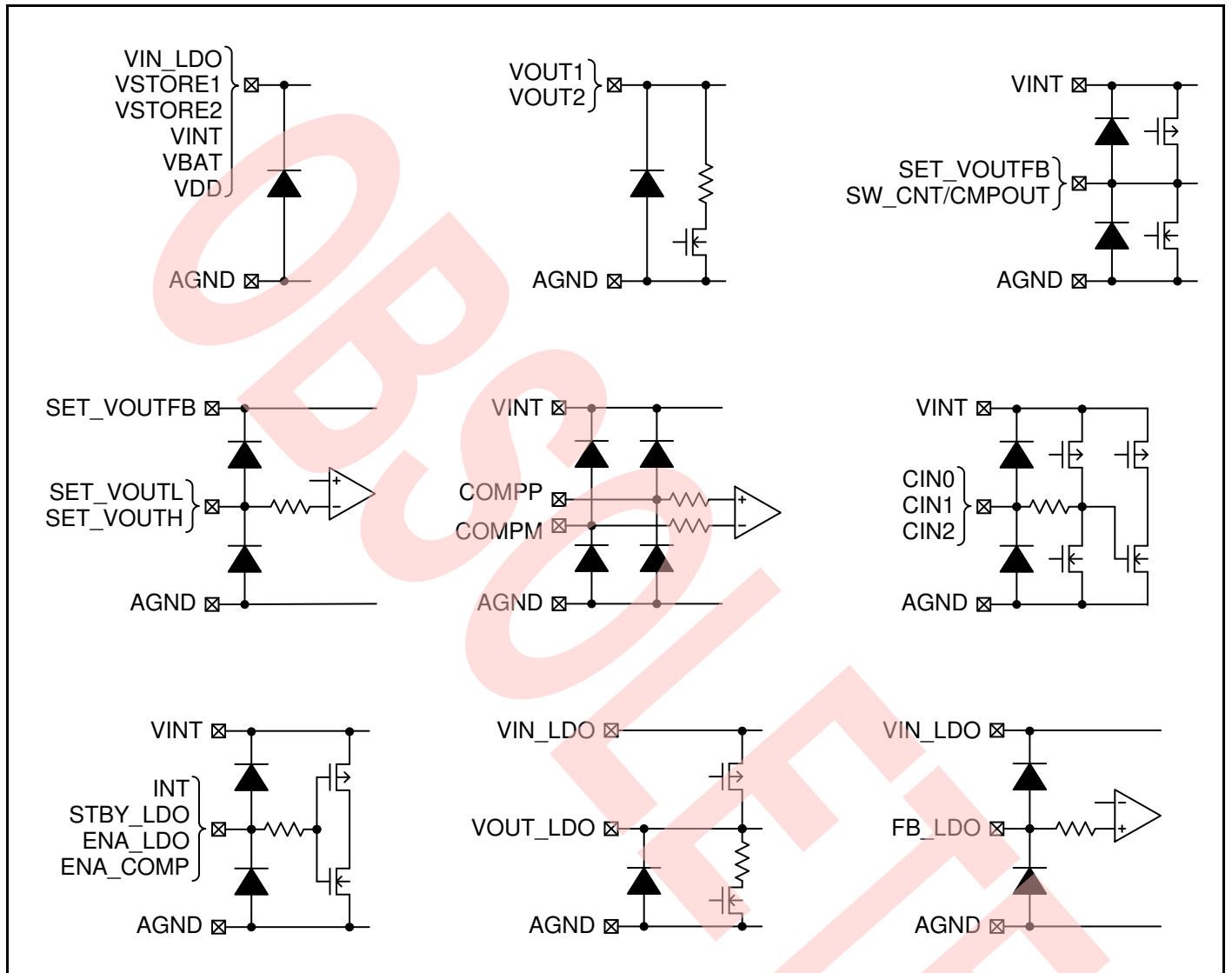



### 5. Architecture Block Diagram

Figure 5-1 Architecture Block Diagram of S6AE102A

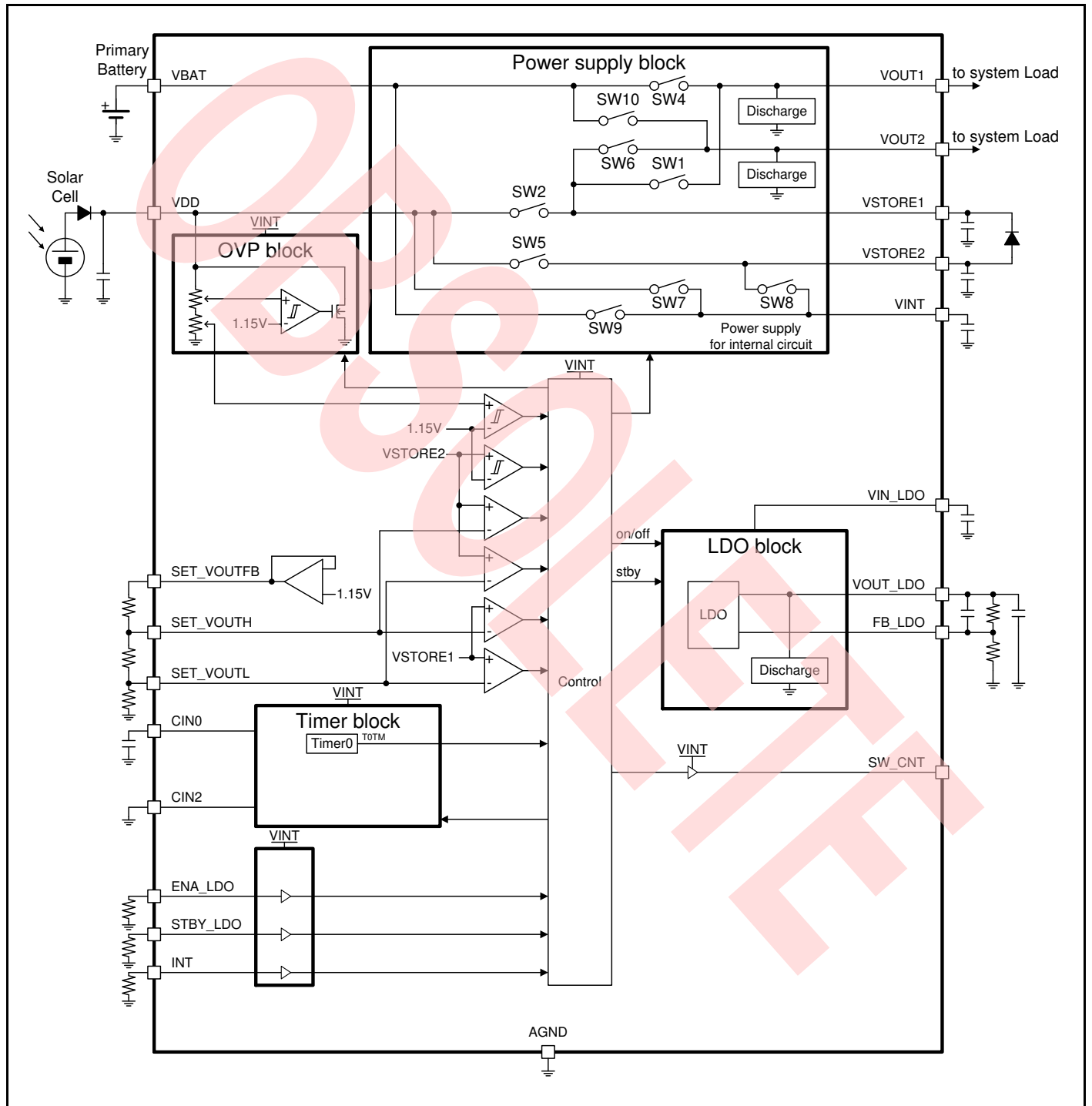
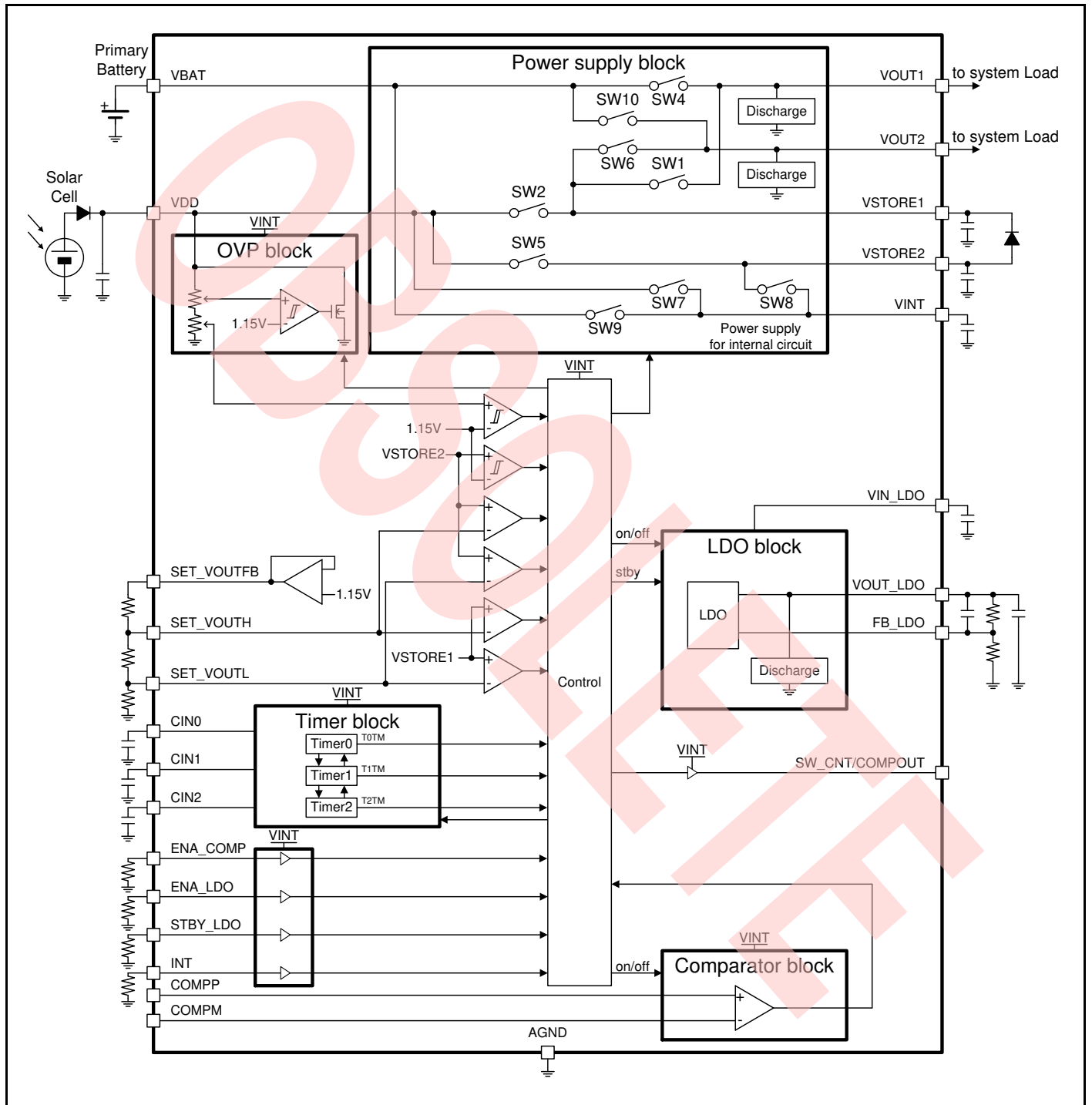

Figure 5-2 Architecture Block Diagram of S6AE103A



## 6. Absolute Maximum Ratings

Parameter	Symbol	Condition	Rating		Unit
			Min	Max	
Power supply voltage (*1)	V <sub>MAX</sub>	VDD, VBAT, VIN_LDO pin	-0.3	+6.9	V
Signal input voltage (*1)	V <sub>INPUTMAX</sub>	SET_VOUTH, SET_VOUTL, INT, ENA_LDO, STBY_LDO, ENA_COMP, COMPP, COMPM pin	-0.3	+6.9	V
VDD slew rate	V <sub>SLOPE</sub>	VDD pin	-	0.1	mV/μs
Power dissipation (*1)	P <sub>D</sub>	Ta ≤+ 25°C	-	1400 (*2)	mW
Storage temperature	T <sub>STG</sub>	-	-55	+125	°C

\*1: When AGND = 0V

\*2: θ<sub>ja</sub> (wind speed 0m/s): +50°C/W

### Warning:

- Semiconductor devices may be permanently damaged by application of stress (including, without limitation, voltage, current or temperature) in excess of absolute maximum ratings. Do not exceed any of these ratings.

## 7. Recommended Operating Conditions

Parameter	Symbol	Condition	Value			Unit
			Min	Typ	Max	
Power supply voltage 1 (*1)	V <sub>VDD</sub>	VDD pin	2.0	3.3	5.5	V
Power supply voltage 2 (*1)	V <sub>VBAT</sub>	VBAT pin	2.0	3.0	5.5	V
Power supply voltage 3 (*1)	V <sub>VINLDO</sub>	VIN_LDO pin	2.0	-	5.3	V
Signal input voltage (*1)	V <sub>INPUT</sub>	INT, ENA_LDO, STBY_LDO, ENA_COMP, COMPP, COMPM pin	-	-	VINT pin voltage (*2)	V
VOUT1 setting resistance	R <sub>VOUT</sub>	Sum of R1, R2, R3	10	-	50	MΩ
LDO setting resistance	R <sub>LDO</sub>	Sum of R4, R5	-	-	100	MΩ
VDD capacitance	C <sub>VDD</sub>	VDD pin	10	-	-	μF
VINT capacitance	C <sub>VINT</sub>	VINT pin	1	-	-	μF
VSTORE1 capacitance	C <sub>VSTORE1</sub>	VSTORE1 pin	100	-	-	μF
VSTORE2 capacitance	C <sub>VSTORE2</sub>	VSTORE2 pin	2000	-	-	μF
VOUT upper limit setting voltage	V <sub>SYSH</sub>	VSTORE1 pin	When not connecting a capacitor to VSTORE2 pin	-	5.2	V
			When connecting a capacitor to VSTORE2 pin	2.5	-	5.2
VOUT lower limit setting voltage	V <sub>SYSL</sub>	VSTORE1 pin	1.1	-	V <sub>SYSH</sub> × 0.9	V
General-purpose comparator input voltage	V <sub>COMP</sub>	COMPP, COMPM pins	0.2	-	VINT pin voltage -1.5 (*2)	V
LDO output setting voltage	V <sub>SETLD</sub>	VOUT_LDO pin	1.3	-	5.0	V
Timer time 0	T <sub>0</sub>	CIN0 pin, Timer 0	0.1	-	3600	s
Timer time 1	T <sub>1</sub>	CIN1 pin, Timer 1	0.1	-	3600	s
Timer time 2	T <sub>2</sub>	CIN2 pin, Timer 2	0.1	-	3600	s
Operating ambient temperature	T <sub>a</sub>	-	-40	-	+85	°C

\*1: When AGND = 0V

\*2: Refer to "Table 9-1 VINT Pin Voltage".

### Warning:

- The recommended operating conditions are required in order to ensure the normal operation of the semiconductor device. All of the device's electrical characteristics are warranted when the device is operated under these conditions.
- Any use of semiconductor devices will be under their recommended operating condition.
- Operation under any conditions other than these conditions may adversely affect reliability of device and could result in device failure.
- No warranty is made with respect to any use, operating conditions or combinations not represented on this data sheet. If you are considering application under any conditions other than listed herein, please contact sales representatives beforehand.

## 8. Electrical Characteristics

The following electrical characteristics are the values excluding the effect of external resistors and external capacitors.

**Table 8-1 Electrical Characteristics (System Overall)**

(Unless specified otherwise, these are the electrical characteristics under the recommended operating environment.)

Parameter	Symbol	Condition	Value			Unit	
			Min	Typ	Max		
Minimum Input power in start-up	$W_{START}$	VDD pin, $T_a = +25^\circ\text{C}$ , $V_{VOUTH}$ setting = 3V. By applying 0.45 $\mu\text{A}$ to VDD, when VOUT1 reaches 2.67V $\times$ 95% after the point when VDD reaches 2.67V.	-	-	1.2	$\mu\text{W}$	
Power detection voltage	$V_{DETH}$	VDD, VBAT, VINT, VSTORE2 pins	1.0	1.4	2.0	V	
Power undetection voltage	$V_{DETL}$		0.9	1.3	1.9	V	
Power detection hysteresis	$V_{DETHYS}$		-	0.1	-	V	
Power detection voltage 2	$V_{DETH2}$		2.0	2.1	2.2	V	
Power undetection voltage 2	$V_{DETL2}$		1.9	2.0	2.1	V	
Power detection hysteresis 2	$V_{DETHYS2}$		-	0.1	-	V	
VOUT upper limit voltage	$V_{VOUTH}$	VSTORE1 pin, VOUT1 Load = 0 mA, VOUT2 Load = 0 mA	$V_{SYSH} \geq 2\text{V}$	$V_{SYSH} \times 0.95$	$V_{SYSH}$	$V_{SYSH} \times 1.05$	V
			$V_{SYSH} < 2\text{V}$	$V_{SYSH} \times 0.935$	$V_{SYSH}$	$V_{SYSH} \times 1.065$	V
Input power reconnect voltage	$V_{VOUTM}$	VSTORE1 pin, VOUT1 Load = 0 mA, VOUT2 Load = 0 mA	$V_{SYSH} \geq 2\text{V}$	$V_{VOUTH} \times 0.9025$	$V_{VOUTH} \times 0.95$	$V_{VOUTH} \times 0.9975$	V
			$V_{SYSH} < 2\text{V}$	$V_{VOUTH} \times 0.88825$	$V_{VOUTH} \times 0.95$	$V_{VOUTH} \times 1.01175$	V
VOUT lower limit voltage	$V_{VOUTL}$	VSTORE1 pin, VOUT1 Load = 0 mA, VOUT2 Load = 0 mA	$V_{SYSL} \geq 2\text{V}$	$V_{SYSL} \times 0.95$	$V_{SYSL}$	$V_{SYSL} \times 1.05$	V
			$V_{SYSL} < 2\text{V}$	$V_{SYSL} \times 0.935$	$V_{SYSL}$	$V_{SYSL} \times 1.065$	V
VSTORE2 storage upper limit voltage	$V_{VST2H}$	VSTORE2 pin	-	$V_{VOUTH}$	-	V	
OVP detection voltage	$V_{OVPH}$	VDD pin	5.2	5.4	5.5	V	
OVP release voltage	$V_{OVPL}$		5.1	5.3	5.4	V	
OVP detection hysteresis	$V_{OVPHYS}$		-	0.1	-	V	
OVP protection current	$I_{OVP}$		VDD pin input current	6	-	-	mA
Input voltage	$V_{IH}$	INT, ENA_LDO, STBY_LDO, ENA_COMP pins	1.1	-	VINT pin voltage (*1)	V	
	$V_{IL}$	INT, ENA_LDO, STBY_LDO, ENA_COMP pins	0	-	0.3	V	
Output voltage	$V_{OH}$	SW_CNT/COMPOUT, SW_CNT pins, Load = 2 $\mu\text{A}$	VINT pin voltage $\times 0.7$ (*1)	-	VINT pin voltage (*1)	V	
	$V_{OL}$	SW_CNT/COMPOUT, SW_CNT pins, Load = 2 $\mu\text{A}$	0	-	VINT pin voltage $\times 0.3$ (*1)	V	

\*1: Refer to "Table 9-1 VINT Pin Voltage".

**Table 8-2 Electrical Characteristics (Consumption Current)**

(Unless specified otherwise, these are the electrical characteristics under the recommended operating environment.)

Parameter	Symbol	Condition	Value			Unit
			Min	Typ	Max	
Consumption current 1	$I_{QIN1}$	VDD pin input current, Energy driven mode (*2), SW2 = OFF, VDD = 3V, open VBAT pin, open VSTORE2 pin, VIN_LDO = GND, INT = GND, ENA_COMP = GND, ENA_LDO = GND, STBY_LDO = GND, Ta = +25°C, SET_VOUTFB resistance=50MΩ, VOUT1 Load = 0 mA, VOUT2 Load = 0 mA	-	280	440	nA
Consumption current 2	$I_{QIN2}$	Sum of $I_{QIN1}$ and $I_{INLD2}$ (LDO operation current) ENA_LDO = VINT (*1)	-	680	1140	nA
Consumption current 3	$I_{QIN3}$	Sum of $I_{QIN1}$ and comparator operation current, ENA_COMP = VINT (*1)	-	300	470	nA

\*1: Refer to "Table 9-1 VINT Pin Voltage".

\*2: Refer to "9.2. Power Gating".

**Table 8-3 Electrical Characteristics (Switch)**
 $VDD \geq 3V$ ,  $VBAT \geq 3V$ ,  $VINT \geq 3V$ ,  $VSTORE2 \geq 3V$ ,  $V_{VOUTL} \geq 3V$ ,  $VSTORE1 \geq V_{VOUTL}$ 

(Unless specified otherwise, these are the electrical characteristics under the recommended operating environment.)

Parameter	Symbol	Condition	Value			Unit
			Min	Typ	Max	
Switch resistance 1	$R_{ON1}$	SW1, In connection of VSTORE1 pin and VOUT1 pin	-	1.5	2.5	Ω
Switch resistance 2	$R_{ON2}$	SW2, In connection of VDD pin and VSTORE1 pin	-	50	100	Ω
Switch resistance 4	$R_{ON4}$	SW4, In connection of VBAT pin and VOUT1 pin	-	1.5	2.5	Ω
Switch resistance 5	$R_{ON5}$	SW5, In connection of VDD pin and VSTORE2 pin	-	50	100	Ω
Switch resistance 6	$R_{ON6}$	SW6, In connection of VSTORE1 pin and VOUT2 pin	-	1.5	2.5	Ω
Switch resistance 10	$R_{ON10}$	SW10, In connection of VBAT pin and VOUT2 pin	-	1.5	2.5	Ω
Discharge resistance	$R_{DIS}$	VOUT1, VOUT2 pins	-	1	2	kΩ

**Table 8-4 Electrical Characteristics (LDO)**

(Unless specified otherwise, these are the electrical characteristics under the recommended operating environment.)

Parameter	Symbol	Condition	Value			Unit
			Min	Typ	Max	
Output voltage	V <sub>OUTLD</sub>	VOUT_LDO pin, VOUT_LDO resistance=20MΩ, Load = 0.01 mA	V <sub>SETLD</sub> ×0.945	-	V <sub>SETLD</sub> ×1.055	V
		VOUT_LDO pin, Ta = +25°C, VIN_LDO = V <sub>OUTLD</sub> +1V, STBY_LDO = VINT (*1), VOUT_LDO resistance=20MΩ, Load = 0.01 mA	V <sub>SETLD</sub> ×0.97	-	V <sub>SETLD</sub> ×1.03	V
Input/output voltage difference (Normal mode)	V <sub>DELLD1</sub>	Between VIN_LDO and VOUT_LDO pins, STBY_LDO = VINT (*1), Load ≤ 1 mA	0.3	-	-	V
Input/output voltage difference (Standby mode)	V <sub>DELLD2</sub>	Between VIN_LDO and VOUT_LDO pins, STBY_LDO = AGND, Load ≤ 0.001 mA	0.3	-	-	V
Maximum output current (Normal mode)	I <sub>OUTLD1</sub>	VOUT_LDO pin, (VIN_LDO-V <sub>OUTLD</sub> ×1.05) > 0.7V STBY_LDO = VINT (*1)	10	-	-	mA
Maximum output current (Standby mode)	I <sub>OUTLD2</sub>	VOUT_LDO pin, (VIN_LDO-V <sub>OUTLD</sub> ×1.05) > 0.7V, STBY_LDO = AGND	0.1	-	-	mA
Line regulation	L <sub>INELD</sub>	VOUT_LDO pin, VIN_LDO = (V <sub>OUTLD</sub> ×1.05+0.7V) to 5.3V	-	-	50	mV
Load regulation (Normal mode)	LOADLD1	VOUT_LDO pin, STBY_LDO = VINT (*1), Load = 1 mA to 10 mA	-	-	50	mV
Load regulation (Standby mode)	LOADLD2	VOUT_LDO pin, STBY_LDO = AGND, Load = 0.001 mA to 0.1 mA	-	-	50	mV
Output current limit	I <sub>LIMLD</sub>	VOUT_LDO pin, STBY_LDO = VINT (*1)	-	50	100	mA
LDO consumption current (Normal mode)	I <sub>INLD1</sub>	Sum of VINT and VIN_LDO input current, Ta = +25°C, STBY_LDO = VINT (*1), Load = 0 mA	-	6	9	μA
LDO consumption current 2 (Standby mode)	I <sub>INLD2</sub>	VIN_LDO input current, Ta = +25°C, STBY_LDO = AGND, Load = 0 mA, VOUT_LDO resistance=20MΩ, V <sub>OUTLD</sub> setting = 1.3V	-	400	700	nA
OFF current	I <sub>OFFLD</sub>	VIN_LDO pin, Ta = +25°C, ENA_LDO = AGND	-	60	120	nA
Discharge resistance	R <sub>DISLD</sub>	VOUT_LDO pin, 1.35 ≤ V <sub>OUTLD</sub> ≤ 5.0V	-	1	2	kΩ

\*1: Refer to "Table 9-1 VINT Pin Voltage".

**Table 8-5 Electrical Characteristics (Timer)**

(Unless specified otherwise, these are the electrical characteristics under the recommended operating environment.)

Parameter	Symbol	Condition	Value			Unit
			Min	Typ	Max	
Accuracy	T <sub>ATM</sub>	Ta = +25°C	-15	-	+15	%
Each timer consumption current	I <sub>QTM</sub>	Timer 0, Timer 1, Timer 2, Ta = +25°C	-	30	55	nA

## 9. Functional Description

### 9.1 Power Supply Control

This IC can operate by two input power supplies, namely, the solar cell voltage VDD and the primary battery voltage VBAT.

When a capacitor is connected to the VSTORE2 pin, the surplus power of the solar cell accumulates in this capacitor and operates as input power supply.

The input power (from solar cell) is accumulated once in the capacitor connected to the VSTORE1 pin. When the voltage of the VSTORE1 pin reaches the threshold or higher, the power gating switch connects VSTORE1 to VOUT1 and VOUT2.

The input power (from primary battery) is not accumulated in the capacitor connected to the VSTORE1 pin. When the voltage of the VBAT pin reaches the threshold or higher, the switch for power gating connects VBAT to VOUT1 and VOUT2.

The VINT pin voltage is output as shown in the table below.

**Table 9-1 VINT Pin Voltage**

VDD Voltage (Solar Cell)	VBAT Voltage (Primary Battery)	VSTORE2 Voltage	VSTORE1 Voltage	VINT Voltage
V <sub>DETL</sub> or less	V <sub>DETL</sub> or less	V <sub>DETL</sub> or less	-	-
		V <sub>DETH</sub> or higher	-	VSTORE2
	V <sub>DETH</sub> or higher	V <sub>DETL</sub> or less	-	VBAT
		V <sub>DETH</sub> or higher	V <sub>VOUTL</sub> detection (*1) V <sub>VOUTH</sub> detection (*2)	VBAT VSTORE2
V <sub>DETH</sub> or higher	V <sub>DETL</sub> or less	V <sub>DETL</sub> or less	-	VDD
		V <sub>DETH</sub> or higher	-	VDD
	V <sub>DETH</sub> or higher	V <sub>DETL</sub> or less	V <sub>VOUTL</sub> detection (*1)	VBAT
			V <sub>VOUTH</sub> detection (*2)	VDD
		V <sub>DETH</sub> or higher	V <sub>VOUTL</sub> detection (*1)	VBAT
			V <sub>VOUTH</sub> detection (*2)	VDD

\*1: Value from when the voltage reaches V<sub>VOUTL</sub> until it reaches V<sub>VOUTH</sub>

\*2: Value from when the voltage reaches V<sub>VOUTH</sub> until it reaches V<sub>VOUTL</sub>

### VDD Input Power Operation

This section describes operation when the VDD pin is set as the input power (Figure 9-1).

When the voltage of the VBAT pin falls to the power undetection voltage (V<sub>DETL</sub> = 1.45 V) or less, and a capacitor is not connected to the VSTORE2 pin.

- [1] When the voltage of the VDD pin reaches the power detection voltage (V<sub>DETH</sub> = 1.55V) or higher, the switch (SW2) connects VDD and VSTORE1 (path S1). Also, when the voltage of the VDD pin falls to the power undetection voltage (V<sub>DETL</sub> = 1.45V) or less, SW2 disconnects the path S1.
- [2] When the voltage of the VSTORE1 pin reaches the threshold value (V<sub>VOUTH</sub>) or higher that was set by the SET\_VOUTH pin, SW2 disconnects the path S1. Also, the VOUT1 switch (SW1) connects VSTORE1 and VOUT1, and the VOUT2 switch (SW6) connects VSTORE1 and VOUT2 (path S2).
- [3] When the voltage of the VSTORE1 pin falls to the input power reconnect voltage (V<sub>VOUTM</sub>) or less, SW2 connects the path S1 (path S1+S2).
- [4] In addition, when the voltage falls to the threshold value (V<sub>VOUTL</sub>) or less that was set by the SET\_VOUTL pin, SW1 and SW6 disconnect the path S2.
- [5] When SW1 and SW6 disconnects the path S2, the discharge function is activated.

Figure 9-1 VDD Input Power Operation

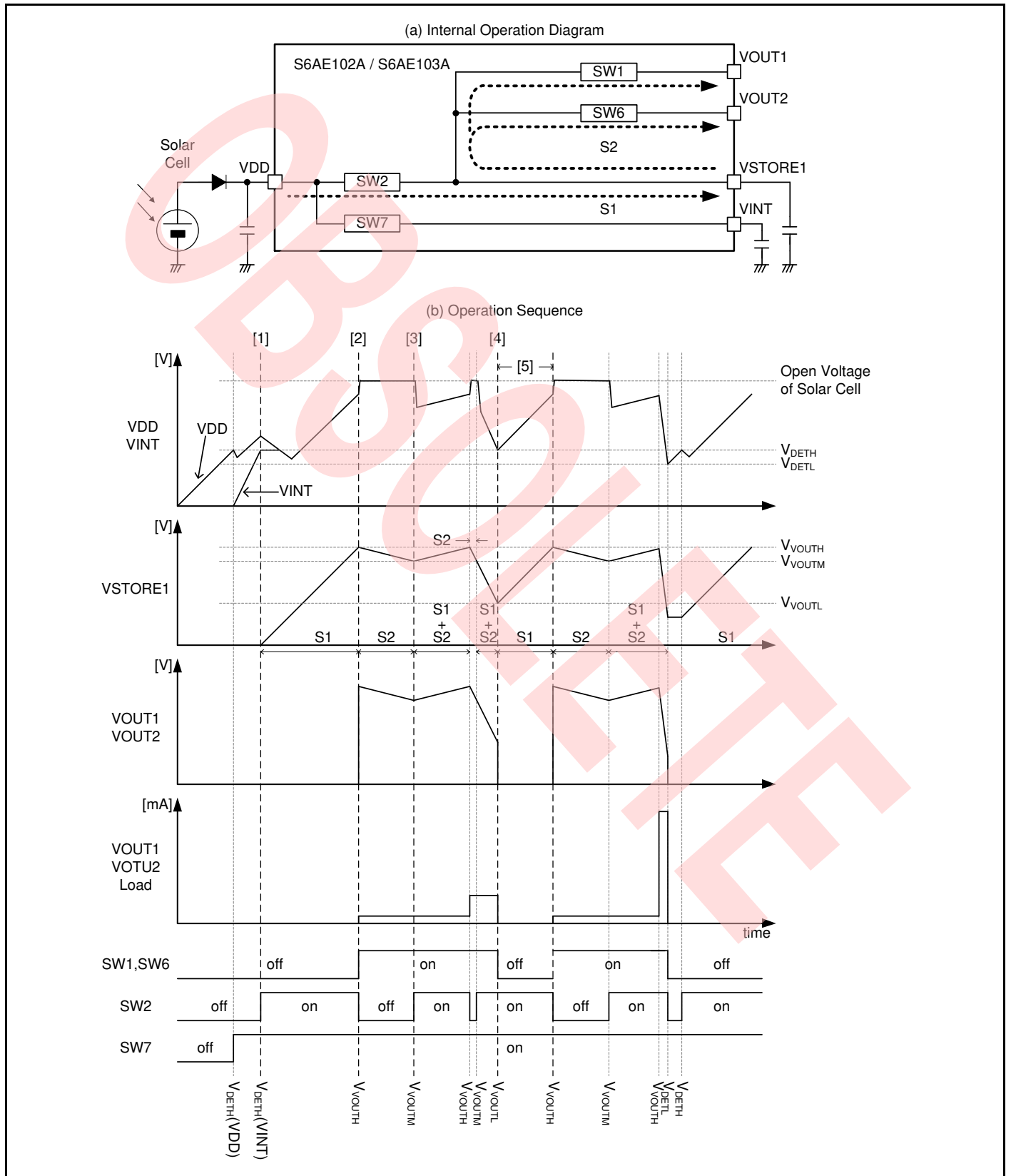



### **VBAT Input Power Operation**

This section describes operation when the VBAT pin is set as the input power (Figure 9-2).

When the voltage of the VDD pin falls to the power undetection voltage ( $V_{DETL} = 1.45\text{ V}$ ) or less, and a capacitor is not connected to the VSTORE2 pin.

- [1] When the voltage of the VBAT pin reaches the power detection voltage ( $V_{DETH} = 1.55\text{ V}$ ) or higher, the switch (SW4) connects VBAT and VOUT1, and the switch (SW10) connects VBAT and VOUT2 (path S3).
- [2] When the voltage of the VBAT pin falls to the power undetection voltage ( $V_{DETL} = 1.45\text{ V}$ ) or less, SW4 and SW10 disconnects the path S3.

Figure 9-2 VBAT Input Power Operation

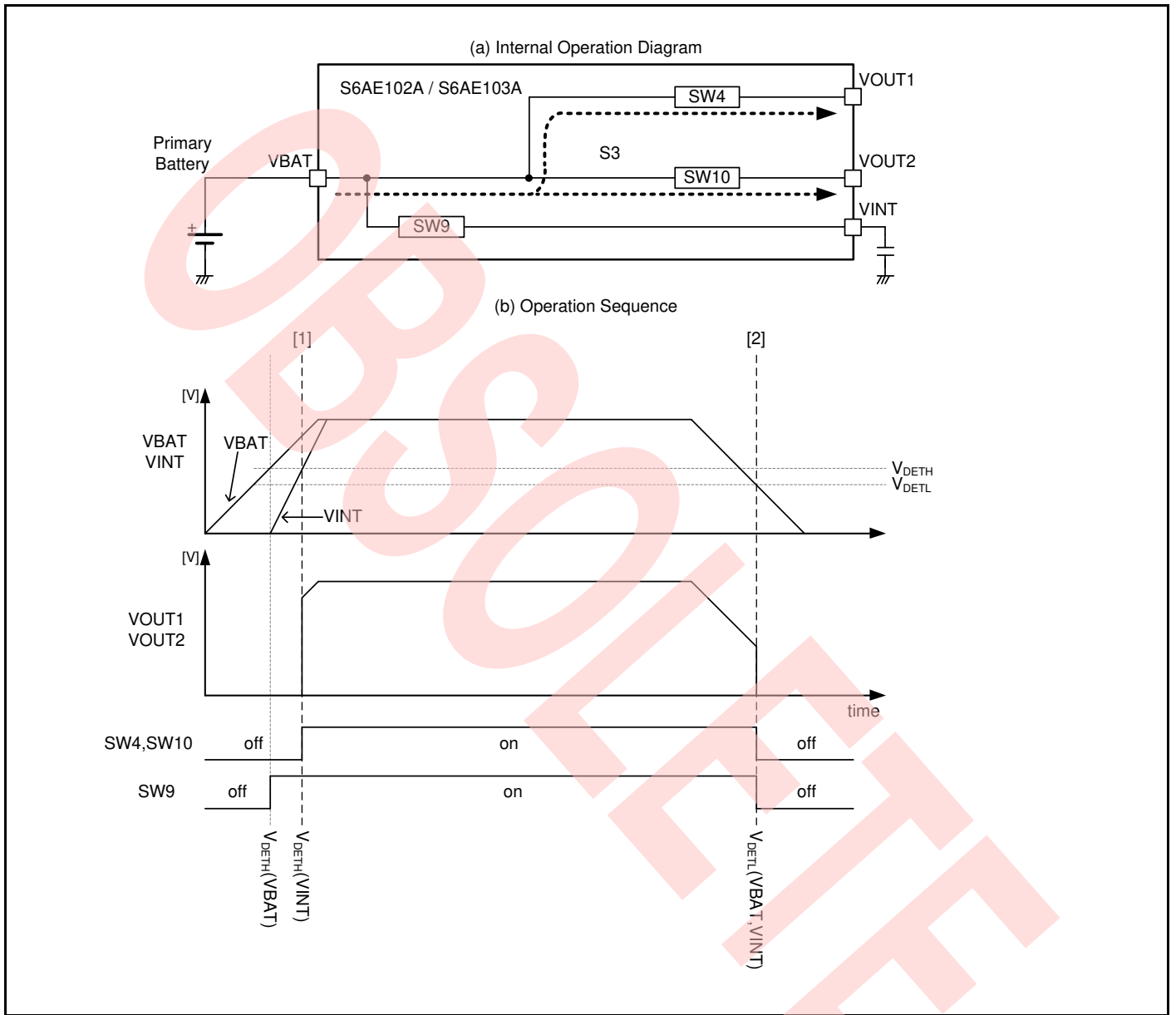

### VDD/VBAT Input Power Operation

This section describes operation when the VDD and VBAT pins are set as the input power (Figure 9-3).

A capacitor is not connected to the VSTORE2 pin.

- [1] When the voltage of the VDD pin and the VBAT pin reaches the power detection voltage ( $V_{DETH} = 1.55\text{ V}$ ) or higher and the voltage of the VSTORE1 pin is not detected as the VOUT upper limit voltage ( $V_{VOUTH}$ ), the VOUT1 switch (SW4) connects VBAT and VOUT1 and the VOUT2 switch (SW10) connects VBAT and VOUT2 (path S3). Also, the switch (SW2) connects VDD and VSTORE1 (path S1).
- [2] When the voltage of the VSTORE1 pin reaches the VOUT upper limit voltage ( $V_{VOUTH}$ ) or higher, SW4 and SW10 disconnect path S3. Also, the VOUT1 switch (SW1) connects VSTORE1 and VOUT1 and the VOUT2 switch (SW6) connects VSTORE1 and VOUT2 (path S2).
- [3] When the voltage of the VSTORE1 pin falls to the input power reconnect voltage ( $V_{VOUTM}$ ) or less, SW2 connects path S1 (path S1 + S2).
- [4] When the voltage of the VSTORE1 pin falls to the VOUT lower limit voltage ( $V_{VOUTL}$ ) or less, switches SW1 and SW6 disconnect path S2. Also, SW4 and SW10 connect path S3 (path S1 + S3).
- [5] When the voltage of the VBAT pin falls to the power undetection voltage ( $V_{DETL} = 1.45\text{ V}$ ) or less, switches SW4 and SW10 disconnect path S3.
- [6] When the voltage of the VSTORE1 pin reaches the VOUT upper limit voltage ( $V_{VOUTH}$ ) or higher, SW1 and SW6 connect path S2 (path S2).

Figure 9-3 VDD/VBAT Input Power Operation

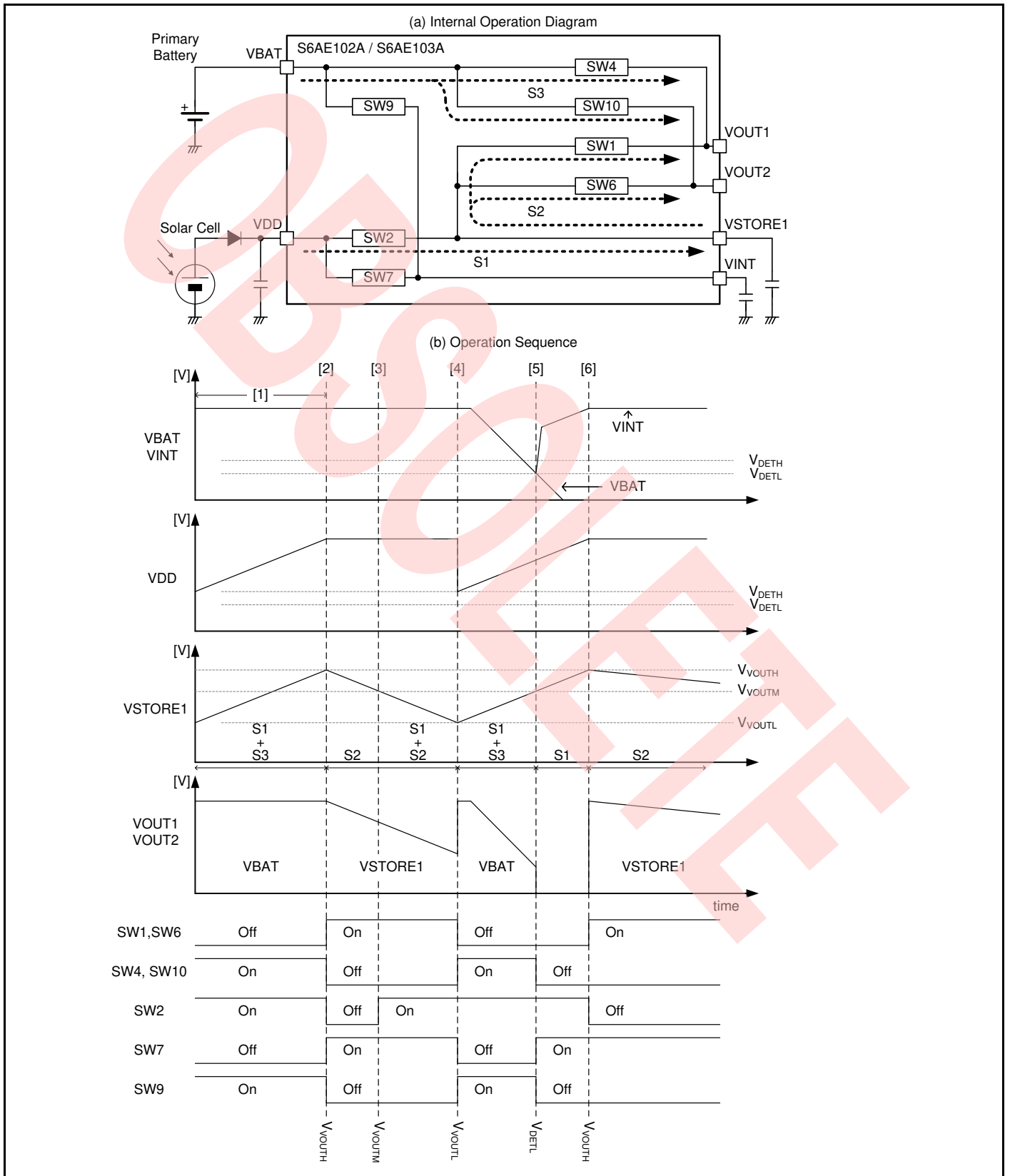

### VDD/VSTORE2 Input Power Operation

This section describes operation when the VDD pin is set as the input power (Figure 9-4).

A capacitor is connected to the VSTORE2 pin.

- [1] When the voltage of the VSTORE1 pin reaches the threshold value ( $V_{VOUTH}$ ) or higher that was set by the SET\_VOUTH pin, switch (SW5) connects VDD and VSTORE2 (path S4).
- [2] When the voltage of the VDD pin falls to the power undetection voltage 2 ( $V_{DETL2} = 2.0\text{ V}$ ) or less, SW5 disconnects path S4. When it reaches the power detection voltage 2 ( $V_{DETH2} = 2.1\text{ V}$ ) or higher, SW5 connects path S4.
- [3] When the voltage of the VSTORE1 pin falls to the threshold value ( $V_{VOUTM}$ ) or less that was set by the SET\_VOUTH pin, SW5 disconnects path S4.
- [4] When the voltage of the VSTORE2 pin reaches the VSTORE2 storage upper limit voltage ( $V_{VST2H}$ ) or higher, SW5 disconnects path S4.

Figure 9-4 VDD/VSTORE2 Input Power Operation

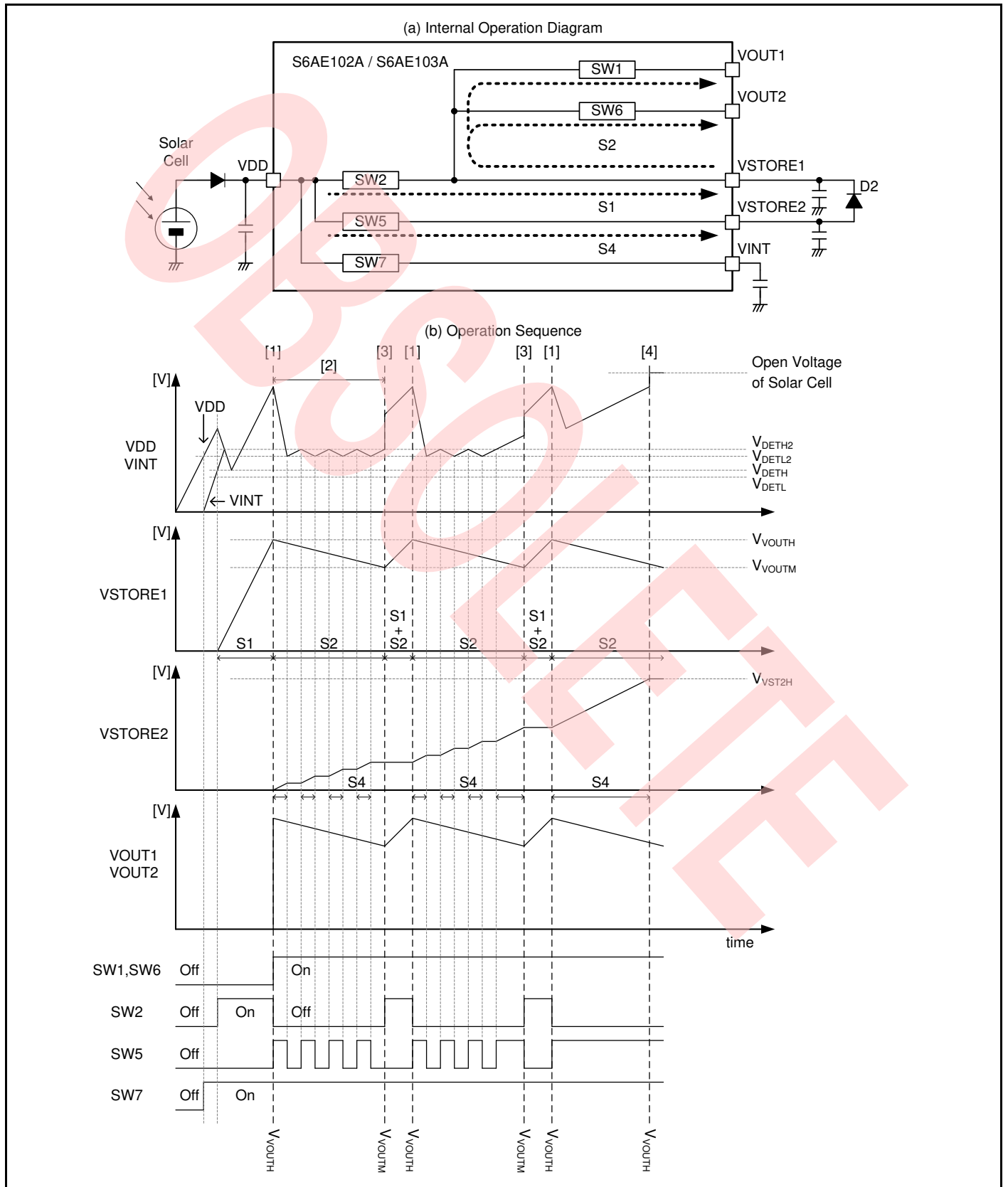

### **VSTORE2 Input Power Operation ( $V_{\text{SYSH}} \geq 2.5\text{V}$ )**

This section describes operation when the VSTORE2 pin is set as the input power (Figure 9-5).

A capacitor is connected to the VSTORE2 pin.

- [1] When the voltage of the VSTORE1 pin falls to the threshold value ( $V_{\text{VOUTM}}$ ) or less that was set by SET\_VOUTH pin, the switch (SW2) connects VDD and VSTORE1 (path S1 + S2)
- [2] Under insufficient light, when VSTORE1 voltage gets lower by the forward voltage drops of the diode (D2) than VSTORE2 voltage, power is supplied from VSTORE2 pin to VSTORE1 pin via D2.
- [3] When the voltage of the VSTORE1 pin falls to the threshold value ( $V_{\text{VOUTL}}$ ) or less that was set by the SET\_VOUTL pin, the VOUT1 switch (SW1) disconnects VSTORE1 and VOUT1 and the VOUT2 switch (SW6) disconnects VSTORE1 and VOUT2.

Figure 9-5 VSTORE2 Input Power Operation

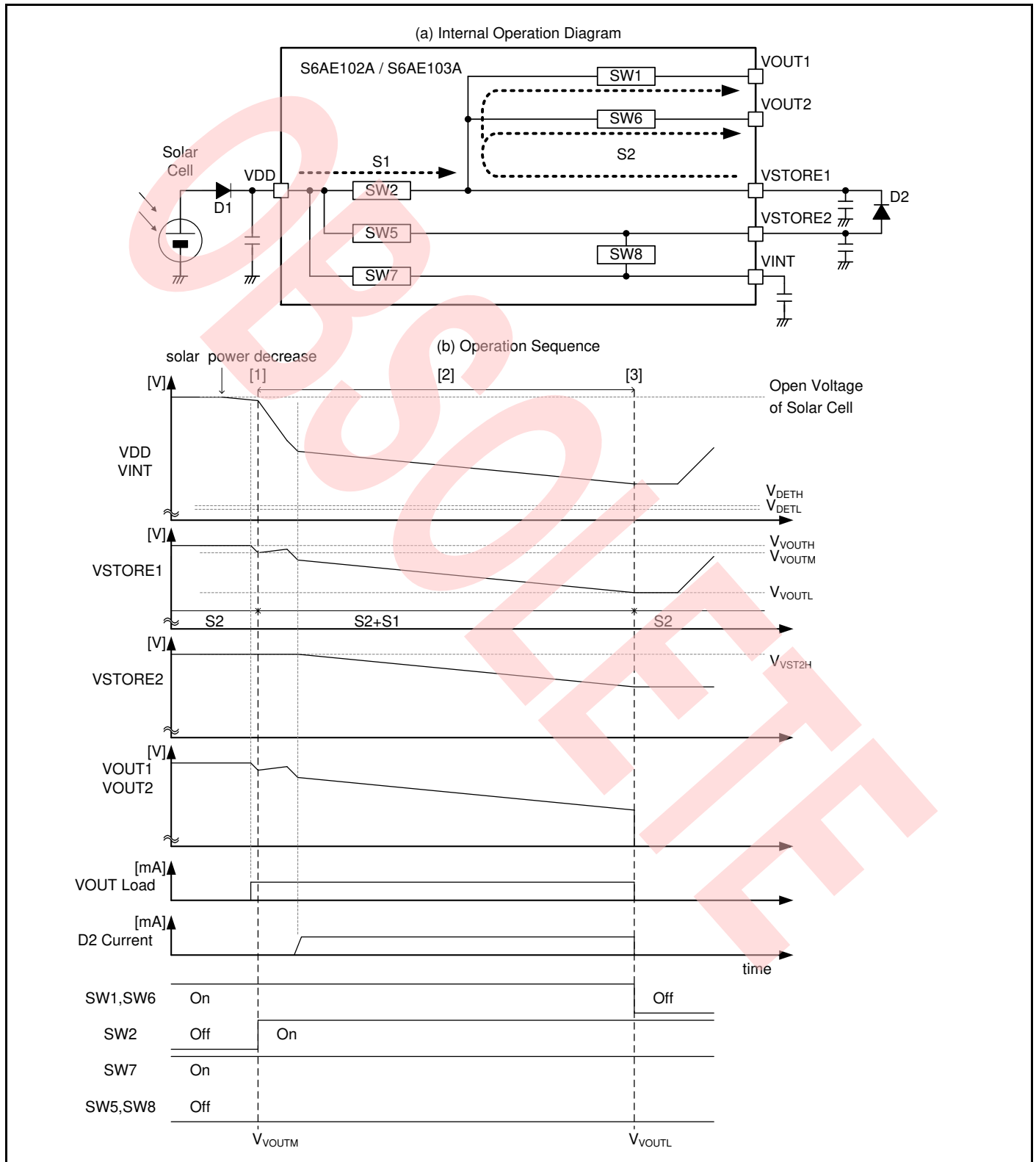



## 9.2 Power Gating

This IC has a power gating function for external systems.

The power gating function is to control supplying power accumulated in VSTORE1 or power from VBAT to external system loads connected to VOUT1 and VOUT2 by internal switches.

The power gating function has four operating modes.

This IC determines the power gating operation mode through the connection status of pins CIN1 and CIN2 at the power detection ( $V_{DETH} = 1.55\text{ V}$ ) timing of the VINT pin.

**Table 9-2 Power Gating Operation Mode**

Each Pin Settings		Operation Mode
CIN1(*1)	CIN2	
Open	Open	Energy driven mode
Open	Connect AGND	Event driven mode 1
Connect capacitor (*2)	Open	Event driven mode 2 (*1)
Connect capacitor (*2)	Connect capacitor (*2)	Timer driven mode (*1)

\*1: S6AE103A only

\*2: For the timer time setting, refer to "11.1 Setting the Operation Conditions".

### Energy Driven Mode

#### 1) VDD input power operation

Switches are controlled by monitoring VSTORE1 voltage.

Internal switches (SW1 and SW6) connect VSTORE1 and VOUT1, as well as VSTORE1 and VOUT2 from when VOUT upper limit voltage ( $V_{VOUTH}$ ) is detected until VOUT lower limit ( $V_{VOUTL}$ ) is detected.

#### 2) VBAT input power operation

Switches are controlled by monitoring VBAT voltage.

Internal switches (SW4 and SW10) connect VBAT and VOUT1, as well as VBAT and VOUT2 from when power detection voltage ( $V_{DETH}$ ) is detected until power undetection voltage ( $V_{DETL}$ ) is detected.

### Event Driven Mode 1

Switches are controlled in the same way as the energy driven mode to supply to VOUT1. The INT input controls switching to supply to VOUT2. While the timer 0 is counting, the flag output (T0TM) disables internal switching controls through INT input. The timer time (T0) is set by the capacitor connected to CIN0.

#### 1) VDD input power operation

Internal switch (SW6) connects VSTORE1 to VOUT2 while INT is high level. Detecting upper limit voltage ( $V_{VOUTH}$ ) is a trigger to start timer 0, after the timer time reaches count (T0), it stops and is reset.

#### 2) VBAT input power operation

Internal switch (SW10) connects VBAT to VOUT2 while INT is high level. Detecting power detection voltage ( $V_{DETH}$ ) is a trigger to start timer 0, after the timer time reaches count (T0), it stops and is reset.

### Event Driven Mode 2

Switches are controlled in the same way as the energy driven mode to supply to VOUT1. The INT input and the flag output (T1TM) control switching to supply to VOUT2.

#### 1) VDD input power operation

Detecting upper limit voltage ( $V_{VOUTH}$ ) is a trigger to start counter, after the timer time reaches count (T0), timer 0 stops and is reset. When the timer time (T0) is set by the capacitor connected to CIN0.

The highness of INT is a trigger to start counter, after the timer time reaches count (T1), timer 1 stops and is reset. When the timer time (T1) is set by the capacitor connected to CIN1.

For each timer, they are reset by detecting VOUT lower limit voltage ( $V_{VOUTL}$ ).

Internal switch (SW6) connects VSTORE1 to VOUT2 while timer 1 is counting. Disables internal switching controls through INT input while the timer 0 is counting.

## 2) VBAT input power operation

Detecting power detection voltage ( $V_{DETH}$ ) is a trigger to start counter, after the timer time reaches count (T0), timer 0 stops and is reset. When the timer time (T0) is set by the capacitor connected to CIN0.

The highness of INT is a trigger to start counter, after the timer time reaches count (T1), timer 1 stops and is reset. When the timer time (T1) is set by the capacitor connected to CIN1.

Each timer is reset by detecting power undetection voltage ( $V_{DETL}$ ).

Internal switch (SW10) connects VBAT to VOUT2 while timer 1 is counting. Disables internal switching controls through INT input while the timer 0 is counting.

## Timer Driven Mode

The timer 0 flag output (T0TM), timer 1 flag output (T1TM), and timer 2 flag output (T2TM) control switching to supply to VOUT1 and VOUT2

### 1) VDD input power operation

This section describes the operation of each timer.

Detecting upper limit voltage ( $V_{VOUTH}$ ) the first time is a trigger to start counter, after the timer time reaches count (T0), timer 0 stops and is reset. From the second time onward, the completion of timer 2 is a trigger to start the count, after the timer time reaches count (T0), the timer stops and is reset. When the timer time (T0) is set by the capacitor connected to CIN0.

Detecting upper limit voltage ( $V_{VOUTH}$ ) the first time is a trigger to start counter, after the timer time reaches count (T1), timer 1 stops and is reset. From the second time onward, the completion of timer 2 is a trigger to start the count, after the timer time reaches count (T1), the timer stops and is reset. When the timer time (T1) is set by the capacitor connected to CIN1.

The completion of timer 1 is a trigger to start counter, after the timer time reaches count (T2), timer 2 stops and is reset. When the timer time (T2) is set by the capacitor connected to CIN2.

Timer 0 and 1 are reset by detecting VOUT lower limit voltage ( $V_{VOUTL}$ ). Timer 2 is reset by power undetection voltage ( $V_{DETL}$ ) of VINT.

This section describes the operation of VOUT1.

Internal switch (SW1) connects VSTORE1 to VOUT1 while timer 1 is counting. Internal switch (SW1) disconnects VSTORE1 and VOUT1 while timer 2 is counting.

This section describes the operation of VOUT2.

Internal switch (SW6) connects VSTORE1 to VOUT2 while timer 1 is counting after timer 0 ends. Internal switch (SW6) disconnects VSTORE1 and VOUT2 while timer 2 is counting.

### 2) VBAT input power operation

This section describes the operation of each timer.

Detecting power detection voltage ( $V_{DETH}$ ) the first time is a trigger to start counter, after the timer time reaches count (T0), timer 0 stops and is reset. From the second time onward, the completion of timer 2 is a trigger to start the count, after the timer time reaches count (T0), the timer stops and is reset. When the timer time (T0) is set by the capacitor connected to CIN0.

Detecting power detection voltage ( $V_{DETH}$ ) the first time is a trigger to start counter, after the timer time reaches count (T1), timer 1 stops and is reset. From the second time onward, the completion of timer 2 is a trigger to start the count, after the timer time reaches count (T1), the timer stops and is reset. When the timer time (T1) is set by the capacitor connected to CIN1.

The completion of timer 1 is a trigger to start counter, after the timer time reaches count (T2), timer 2 stops and is reset. When the timer time (T2) is set by the capacitor connected to CIN2.

Each timer is reset by detecting power undetection voltage ( $V_{DETL}$ ).

This section describes the operation of VOUT1.

Internal switch (SW4) connects VBAT to VOUT1 while timer 1 is counting. Internal switch (SW4) disconnects VBAT and VOUT1 while timer 2 is counting.

This section describes the operation of VOUT2.

Internal switch (SW10) connects VBAT to VOUT2 while timer 1 is counting after timer 0 ends. Internal switch (SW10) disconnects VBAT and VOUT2 while timer 2 is counting.

Figure 9-6 Power Gating Operation (VDD Input Power)

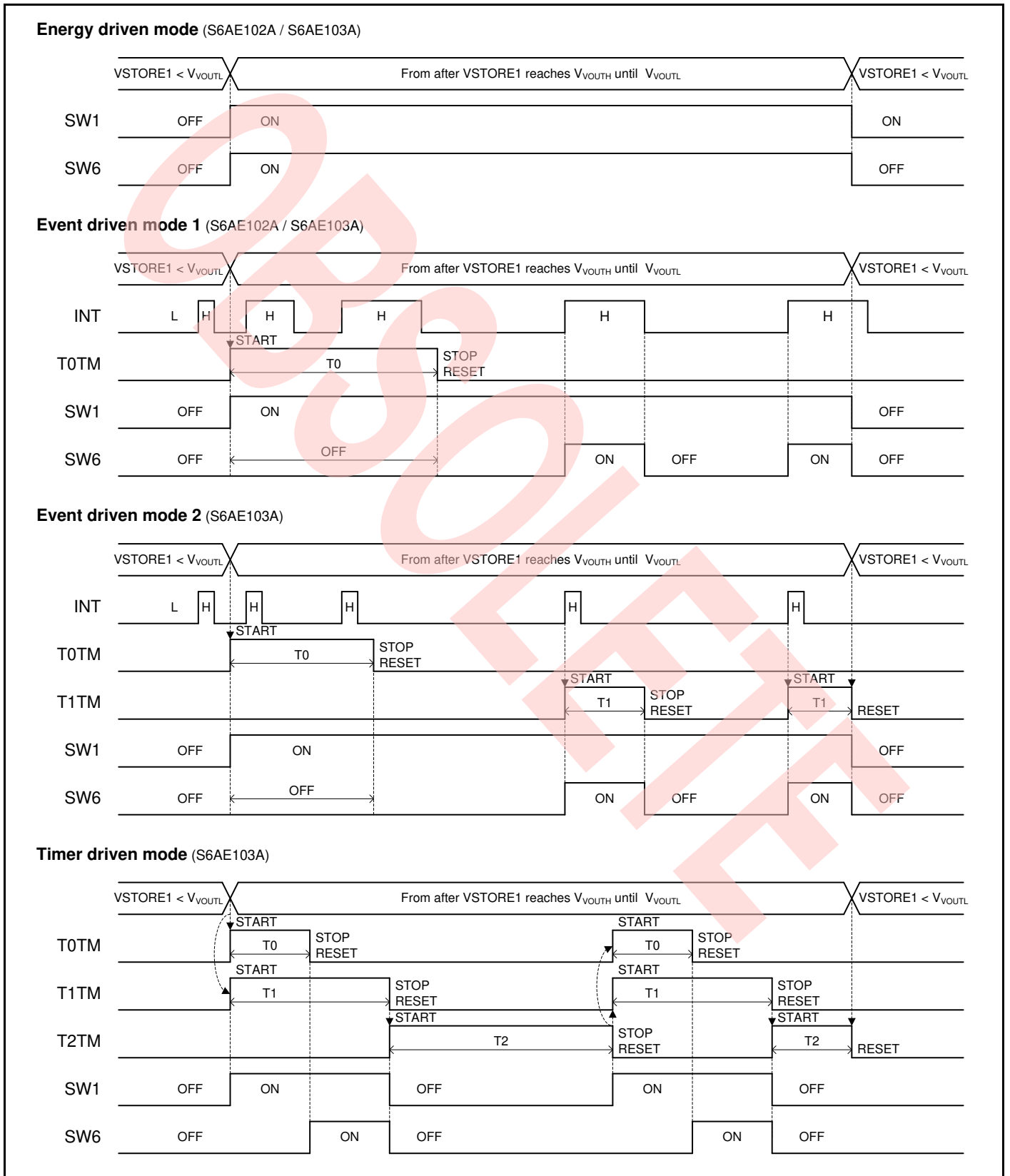
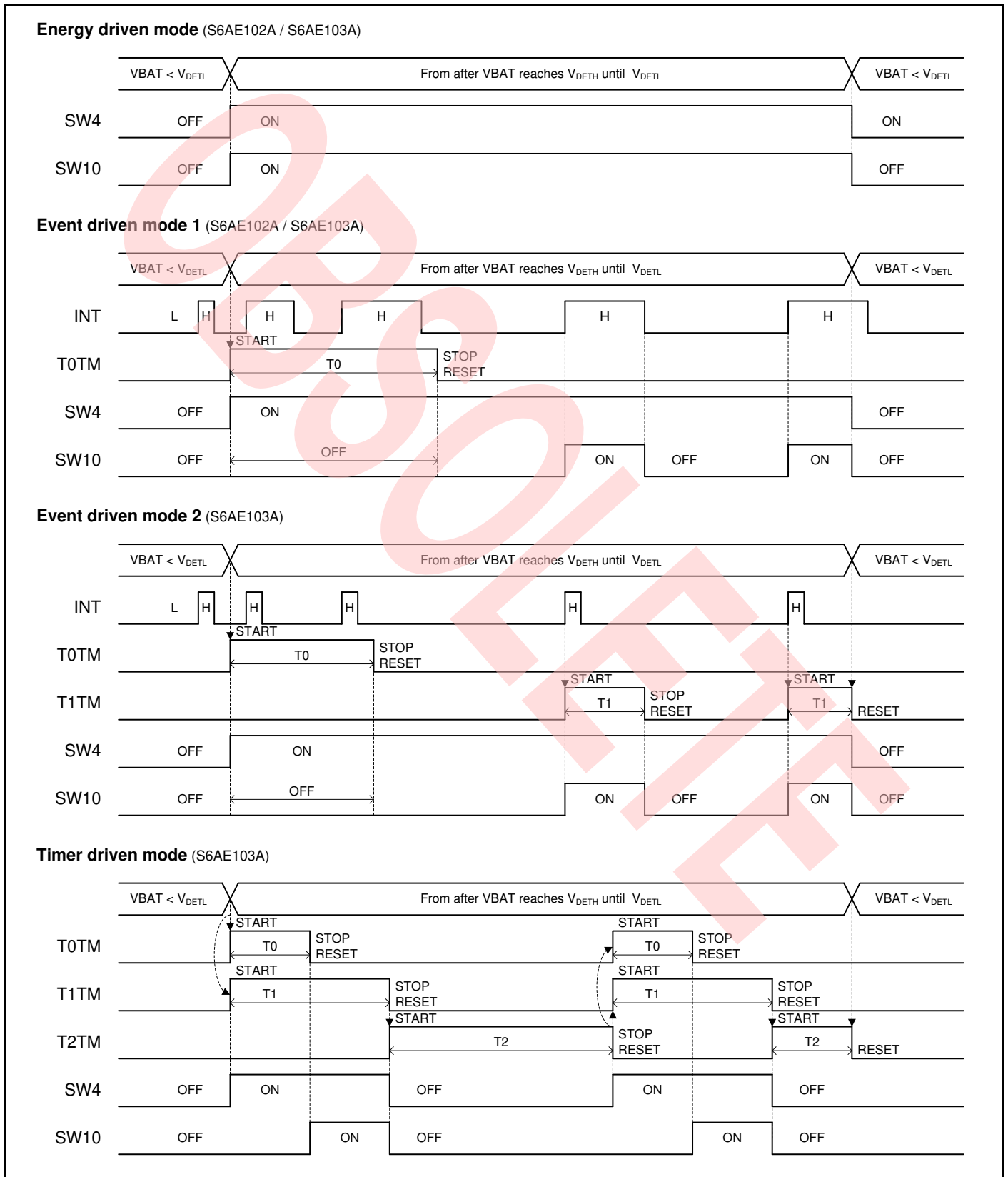

Figure 9-7 Power Gating Operation (VBAT Input Power)



### 9.3 Discharge

This IC has VOUT1 pin, VOUT2 pin, and VOUT\_LDO pin discharge functions.

While SW1 and SW4 are OFF, the discharge circuit function between the VOUT1 pin and GND works. The VOUT1 pin's power is discharged to GND level.

While SW6 and SW10 are OFF, the discharge circuit function between the VOUT2 pin and GND works. The VOUT2 pin's power is discharged to GND level.

While LDO is OFF, the discharge circuit function between the VOUT\_LDO pin and GND works. The VOUT\_LDO pin's power is discharged to GND level.

### 9.4 SW\_CNT Control

This IC has a control signal output function for external switching.

#### S6AE102A

The signal, which is interlocked with the switch for VOUT1, is output at the SW\_CNT pin. While the VBAT input power is operating, it is interlocked to the ON/OFF control of the switch (SW4) between VBAT and VOUT1. While the VDD and VSTORE2 input power is operating, it is interlocked to the ON/OFF control of the switch (SW1) between VSTORE1 and VOUT1. Output to the SW\_CNT pin is High while SW1 or SW4 is ON.

#### S6AE103A

While ENA\_COMP pin is Low, the signal, which is interlocked with the switch for VOUT1, is output at the SW\_CNT/COMPOUT pin. While the VBAT input power is operating, it is interlocked to the ON/OFF control of the switch (SW4) between VBAT and VOUT1. While the VDD and VSTORE2 input power is operating, it is interlocked to the ON/OFF control of the switch (SW1) between VSTORE1 and VOUT1. Output to the SW\_CNT/COMPOUT pin is High while SW1 or SW4 is ON.

### 9.5 General-Purpose Comparator

#### S6AE103A

This IC has one general-purpose comparator.

It compares the voltage at the COMPP pin and the COMPM pin while ENA\_COMP pin is High, and outputs the results to the SW\_CNT/COMPOUT pin.

**Table 9-3 General-Purpose Comparator Operation**

Each Pin Settings		SW_CNT/COMPOUT (Output)
ENA_COMP	COMPP, COMPM	
L	-	Operation described in "9.4 SW_CNT Control"
H	COMPP < COMPM	L
	COMPP > COMPM	H
	"COMPP = COMPM" is prohibited	L or H

### 9.6 LDO

This IC has one LDO with VIN\_LDO pin as a power supply.

The output voltage is set by the resistance value at VOUT\_LDO pin and FB\_LDO pin connection. The discharge function operates while output is stopped.

Also, there are two operating modes, standby mode for operating at low power consumption, and normal mode in which the maximum output current is 10 mA, which are set at the STBY\_LDO pin. Refer to the following table for the LDO output state.

**Table 9-4 LDO Operation Mode**

Each Pin Settings		LDO Output State
ENA_LDO	STBY_LDO	
L	L	Output is stopped
	H	
H	L	Standby mode
	H	Normal mode

### 9.7 Over Voltage Protection (OVP)

This IC has an input over voltage protection (OVP) function for the VDD pin voltage.

When the VDD pin voltage reaches the OVP detection voltage ( $V_{OVPH} = 5.4V$ ) or higher, the OVP current ( $I_{OVP}$ ) from the VDD pin is drawn in for limiting the increase in the VDD pin voltage for preventing damage to the IC. Also, when the OVP release voltage ( $V_{OVPL} = 5.3V$ ) or less is reached, drawing-in of the OVP current is stopped.

Figure 9-8 OVP Operation

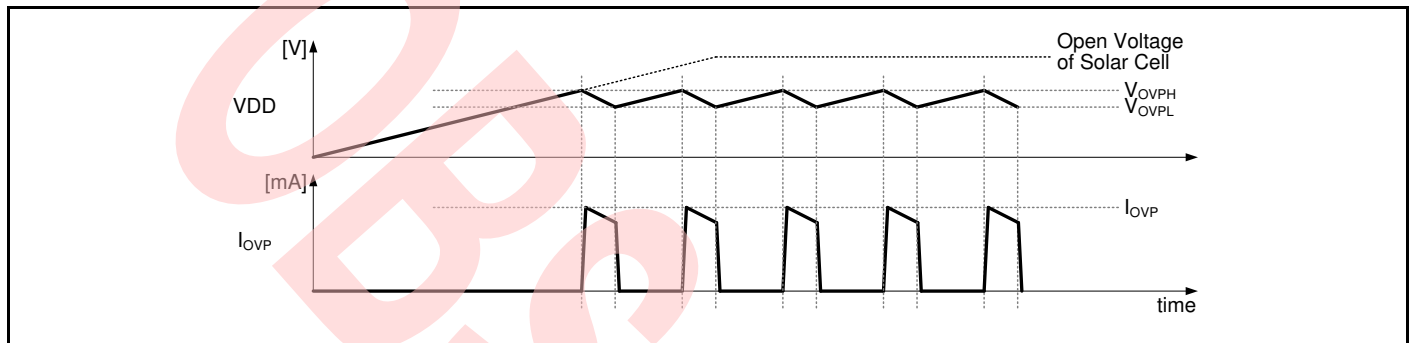

## 10. Application Circuit Example and Parts list

Figure 10-1 Application Circuit Example of S6AE102A

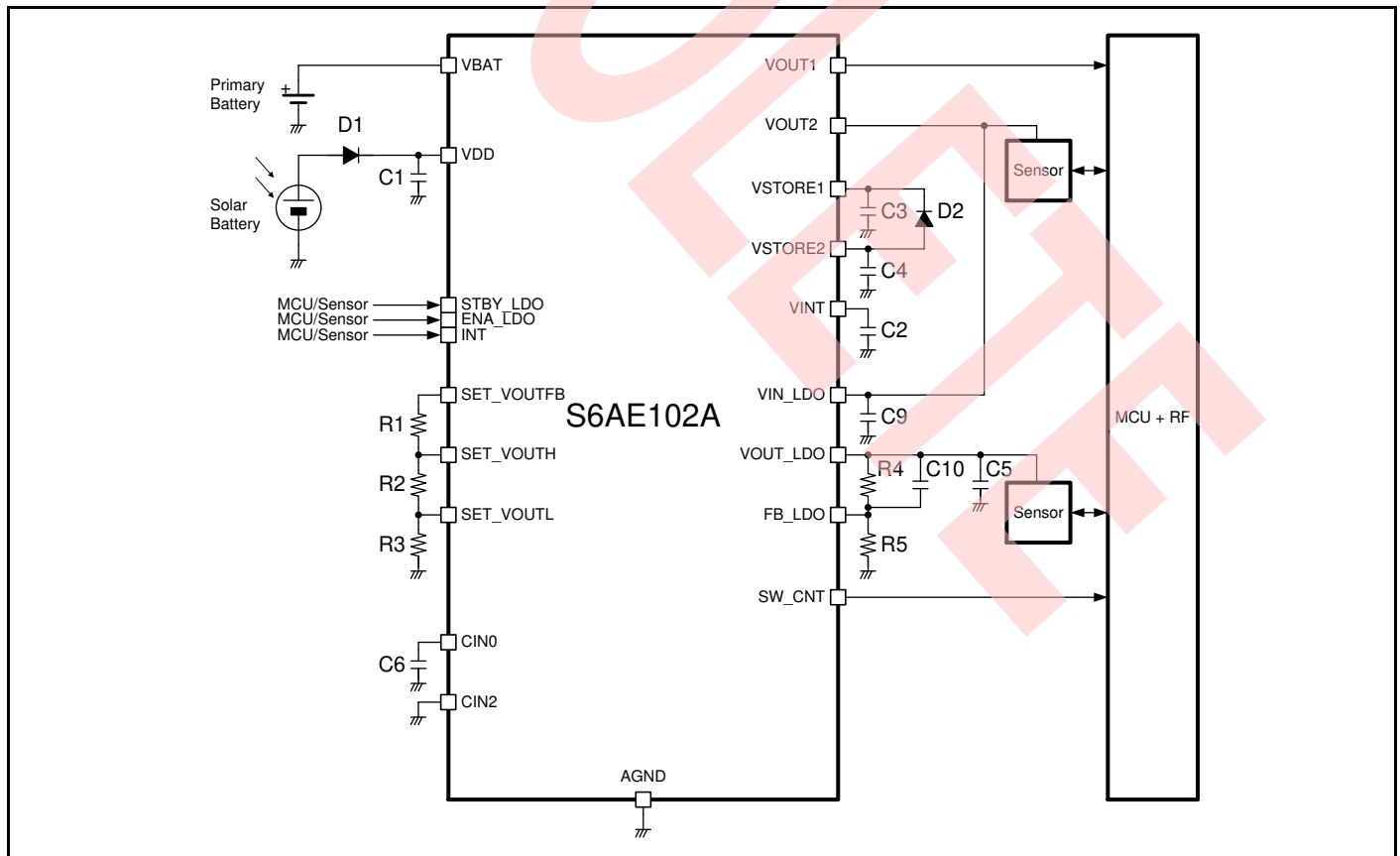

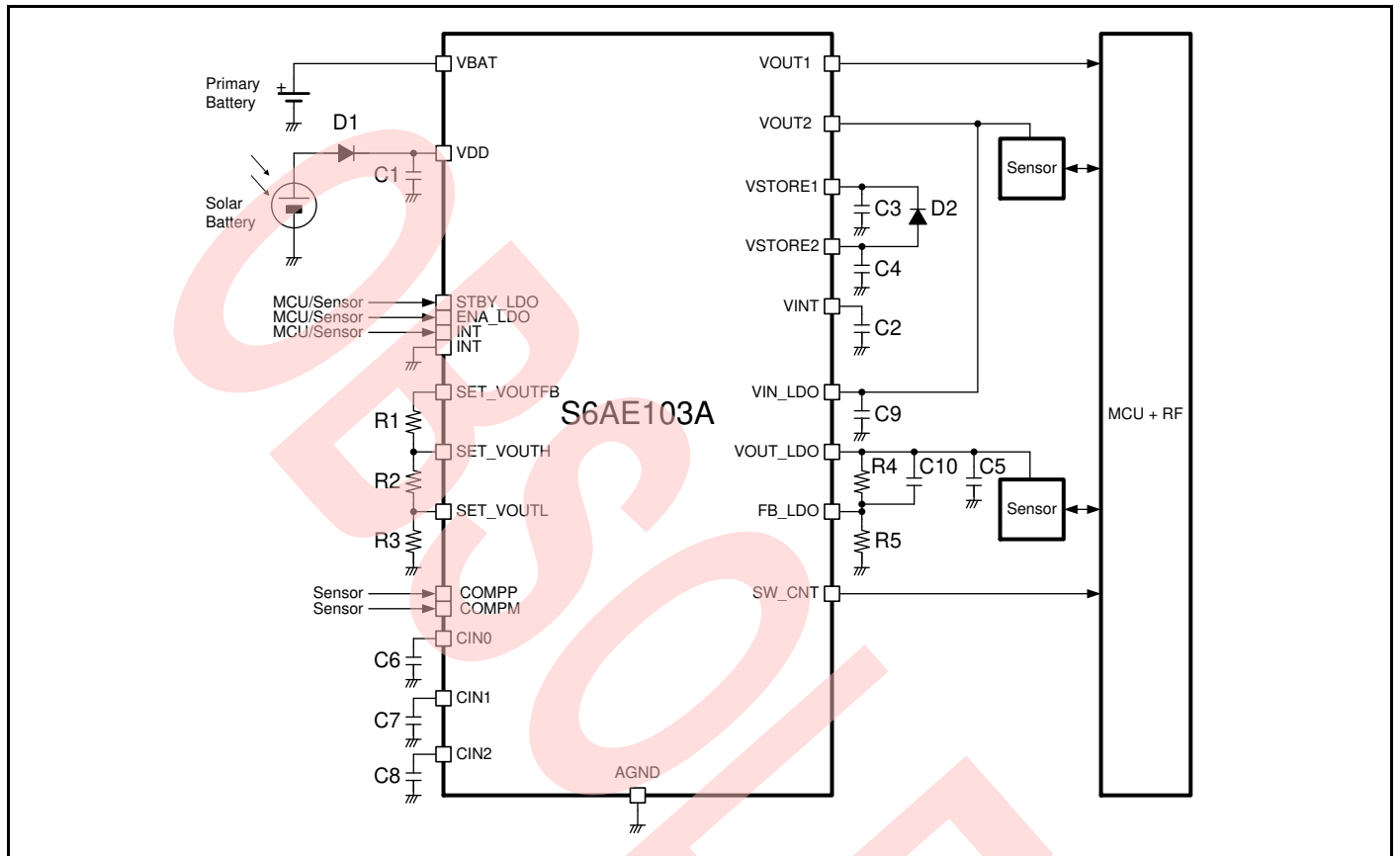
**Figure 10-2 Application Circuit Example of S6AE103A**

**Table 10-1 Parts List**

Symbol	Item	Specification	Remarks
C1	Ceramic capacitor	10 $\mu$ F	16 V, $\pm 20$ %, X5R, 0603
C2	Ceramic capacitor	1 $\mu$ F	16 V, $\pm 10$ %, X5R, 0402
C3	Ceramic capacitor	100 $\mu$ F	6.3 V, $\pm 20$ %, X5R, 1206
C4	Ceramic capacitor	0.5F	5.5V, $-20$ % ~ $+80$ %
C5	Ceramic capacitor	10 $\mu$ F	16 V, $\pm 20$ %, X5R, 0603
C6	Ceramic capacitor	150 pF (*1)	50 V, $\pm 5$ %, C0G, 0603
C7	Ceramic capacitor	330 pF (*1)	50 V, $\pm 5$ %, C0G, 0603
C8	Ceramic capacitor	330 pF (*1)	50 V, $\pm 5$ %, C0G, 0603
C9	Ceramic capacitor	1 $\mu$ F	16 V, $\pm 10$ %, X5R, 0402
C10	Ceramic capacitor	220 pF	50 V, $\pm 5$ %, C0G, 0603
R1	Resistor	6.8 M $\Omega$ (*2)	1/10 W, $\pm 1$ %, 0603
R2	Resistor	2.7 M $\Omega$ (*2)	1/10 W, $\pm 1$ %, 0603
R3	Resistor	9.1 M $\Omega$ (*2)	1/10 W, $\pm 1$ %, 0603
R4	Resistor	5.6 M $\Omega$ (*3)	1/10 W, $\pm 1$ %, 0603
R5	Resistor	10.0 M $\Omega$ (*3)	1/10 W, $\pm 1$ %, 0603
D1	Diode	-	Schottky barrier diode, 40V, 100 mA
D2	Diode	-	Schottky barrier diode, 40V, 100 mA

\*1: Timer time 0 (T0)  $\approx 0.26$ s by the use of C6, Timer time 1 and 2 (T1, T2)  $\approx 0.57$ s by the use of C7 or C8.

\*2: VOUT upper limit voltage ( $V_{VOUTH}$ )  $\approx 3.32$ V, VOUT lower limit voltage ( $V_{VOUTL}$ )  $\approx 2.65$ V.

\*3: LDO output voltage ( $V_{VOUTLDO}$ )  $\approx 1.79$ V

## 11. Application Note

### 11.1 Setting the Operation Conditions

#### Setting of Output Voltage (VOUT1, VOUT2)

The VOUT1 and VOUT2 output voltage of this IC can be set by changing the resistors connecting the SET\_VOUTH pin and SET\_VOUTL pin. This is because the VOUT upper limit voltage ( $V_{VOUTH}$ ) and VOUT lower limit voltage ( $V_{VOUTL}$ ) are set based on the connected resistors. The SET\_VOUTFB pin outputs a reference voltage for setting the VOUT upper limit voltage and VOUT lower limit voltage. The voltages applied to the SET\_VOUTH and SET\_VOUTL pins are produced by dividing this reference voltage outside the IC.

**Figure 11-1 Setting of Output Voltage (VOUT1, VOUT2)**

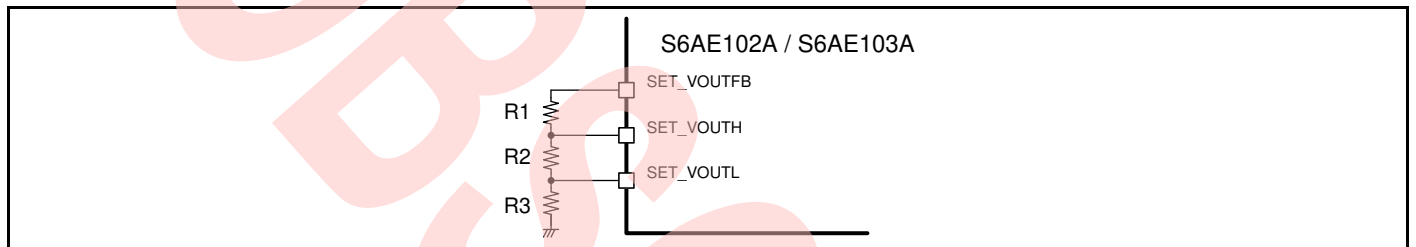

The VOUT upper limit voltage ( $V_{VOUTH}$ ) and VOUT lower limit voltage ( $V_{VOUTL}$ ) can be calculated using the formulas below.

VOUT upper limit voltage

$$V_{VOUTH} [V] = \frac{57.5 \times (R2 + R3)}{11.1 \times (R1 + R2 + R3)}$$

VOUT lower limit voltage

$$V_{VOUTL} [V] = \frac{57.5 \times R3}{11.1 \times (R1 + R2 + R3)}$$

The characteristics when the total for R1, R2, and R3 is 10 M $\Omega$  or more (consumption current 1 is 50 M $\Omega$ ) are shown in "8. Electrical Characteristics".

#### Setting of LDO Output Voltage (VOUT\_LDO)

The VOUT\_LDO output voltage of this IC can be set by changing the resistors connecting the VOUT\_LDO pin and FB\_LDO pin.

**Figure 11-2 Setting of LDO Output Voltage (VOUT\_LDO)**

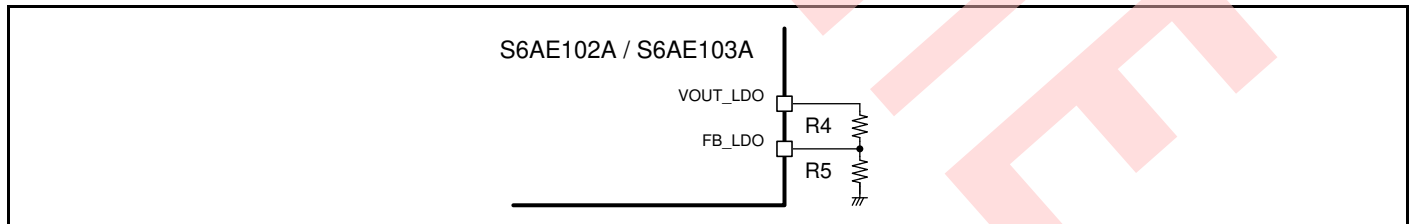

The LDO output voltage ( $V_{OUTLD}$ ) can be calculated using the formula below.

$$V_{OUTLD} [V] = \frac{1.15 \times (R4 + R5)}{R5}$$

#### Setting of Timer Time (T0, T1, T2)

The timer times 0, 1, and 2 (T0, T1, and T2) are set according to the capacitance value at the connections between the CIN0, CIN1, and CIN2 pins and the AGND pin.

The timer time 0 (T0), timer time 1 (T1) and timer time 2 (T2) can be calculated using the formula below.

$$T [s] = 0.5455 \times C [F] \times 10^9 + 0.01327 [s]$$



## 12. Development Support

This IC has a set of documentation, such as application notes, development tools, and online resources to assist you during your development process. Visit [www.cypress.com/energy-harvesting](http://www.cypress.com/energy-harvesting) to find out more.

## 13. Reference Data

For the circuit diagram of the reference data, Refer to "10. Application Circuit Example and Parts list".

Figure 13-1 Reference Data

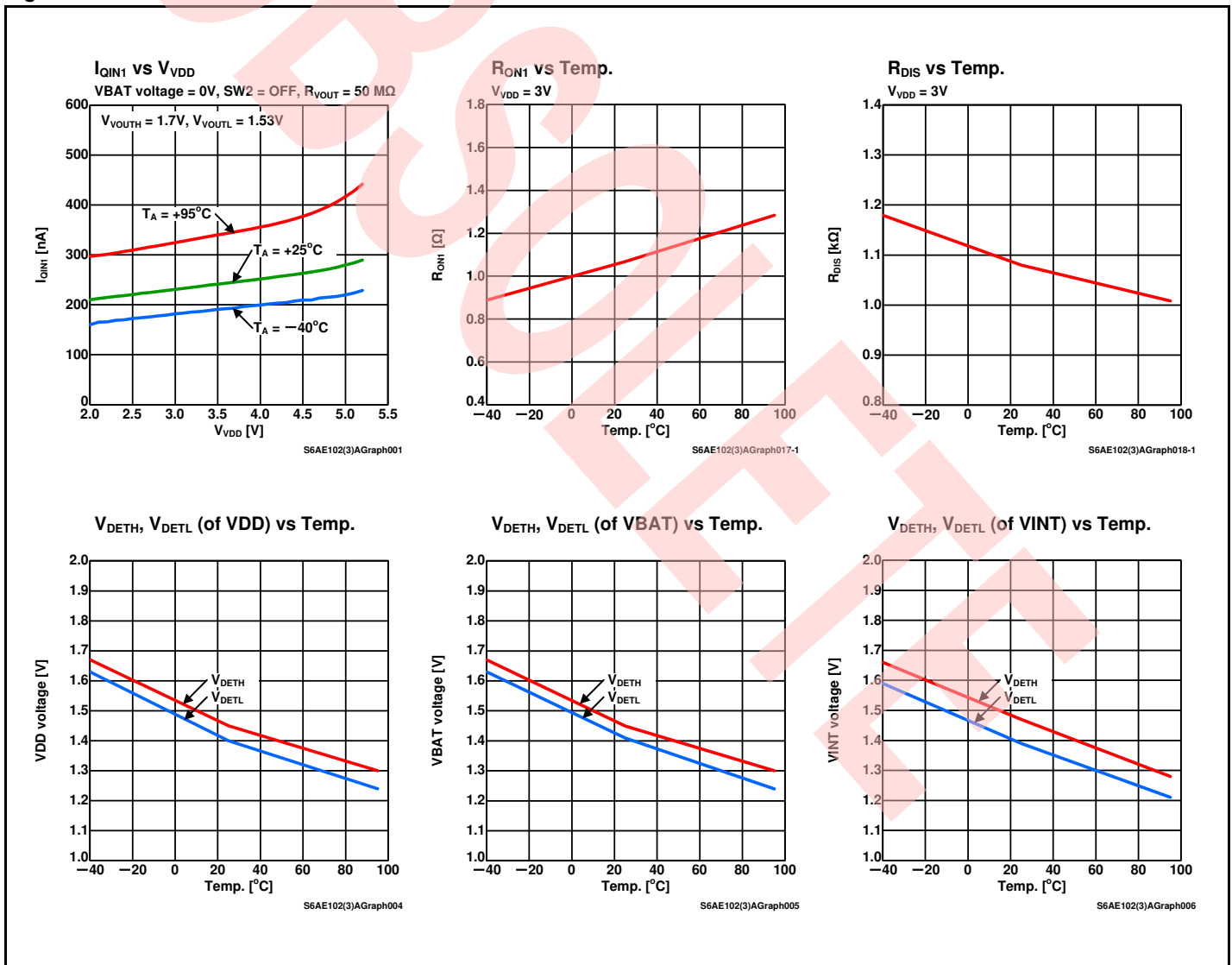

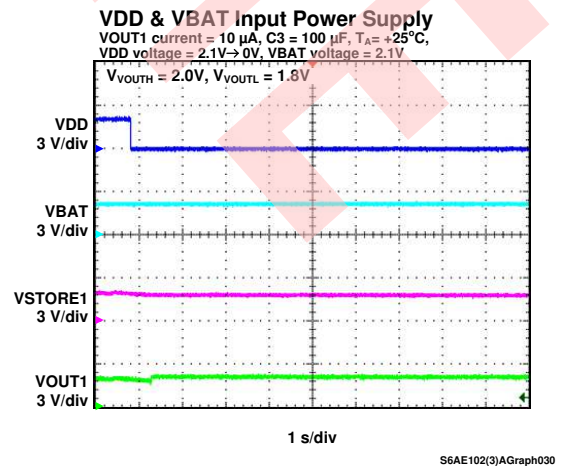
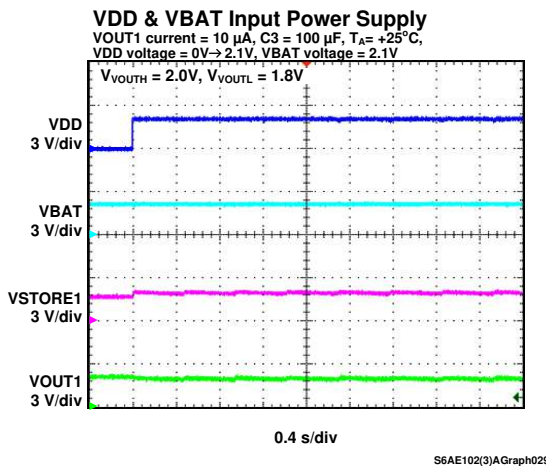
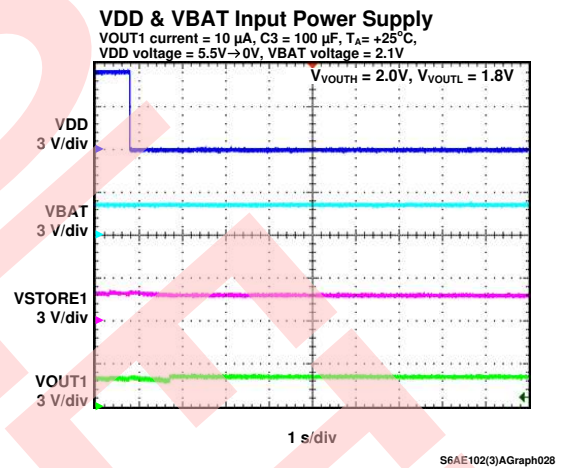
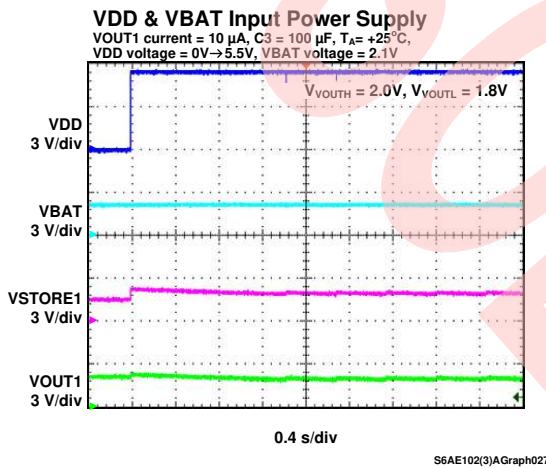
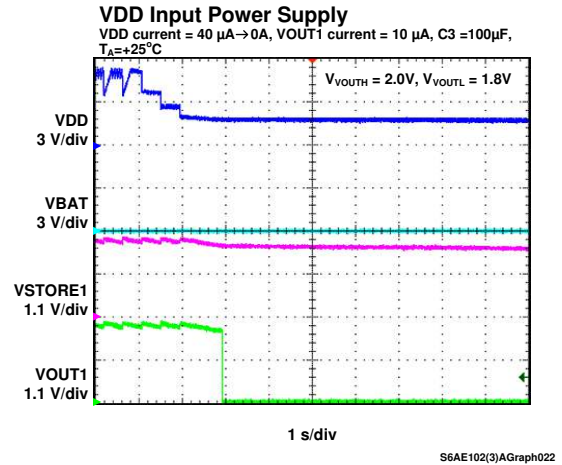
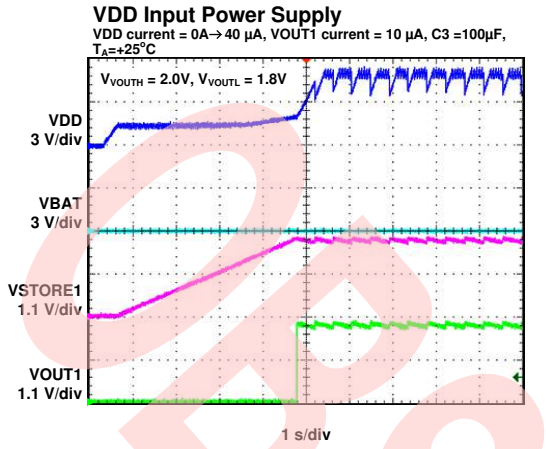

## 14. Usage Precaution

Printed circuit board ground lines should be set up with consideration for common impedance.

### Take appropriate measures against static electricity.

- Containers for semiconductor materials should have anti-static protection or be made of conductive material.
- After mounting, printed circuit boards should be stored and shipped in conductive bags or containers.
- Work platforms, tools, and instruments should be properly grounded.
- Working personnel should be grounded with resistance of 250 kΩ to 1 MΩ in serial body and ground.

### Do not apply negative voltages.

The use of negative voltages below -0.3V may make the parasitic transistor activated to the LSI, and can cause malfunctions.

## 15. RoHS Compliance Information

This product has observed the standard of lead, cadmium, mercury, Hexavalent chromium, polybrominated biphenyls (PBB), and polybrominated diphenyl ethers (PBDE).

## 16. Ordering Information

Table 16-1 Ordering Part Number

Part number (MPN)	Package
S6AE102A0DGN1B000	Plastic QFN-20 (0.5 mm pitch), 20-pin (VNF020)
S6AE103A0DGN1B000	Plastic QFN-24 (0.5 mm pitch), 24-pin (VNF024)

MPN: Marketing Part Number

Figure 16-1 Ordering Part Number Definitions

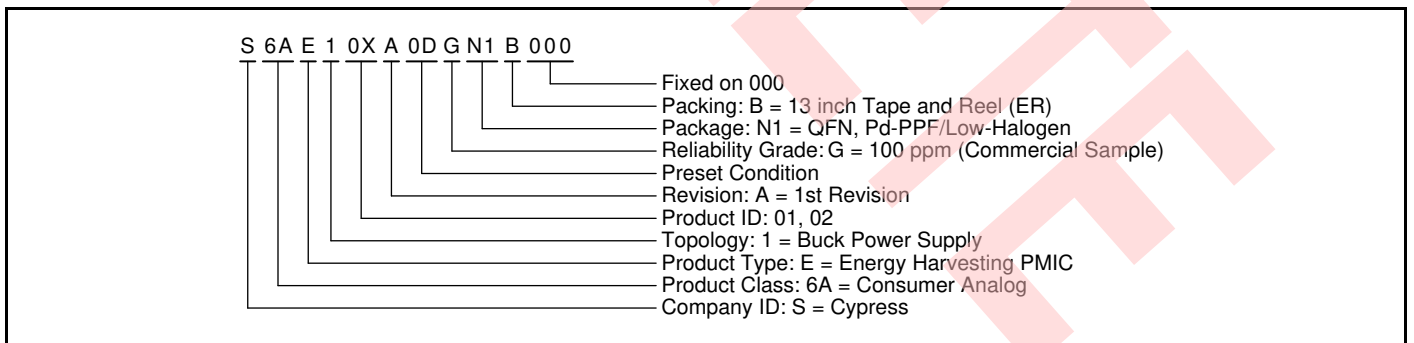

### 17. Package Dimensions

Figure 17-1 Package Dimensions of S6AE102A (VNF020)

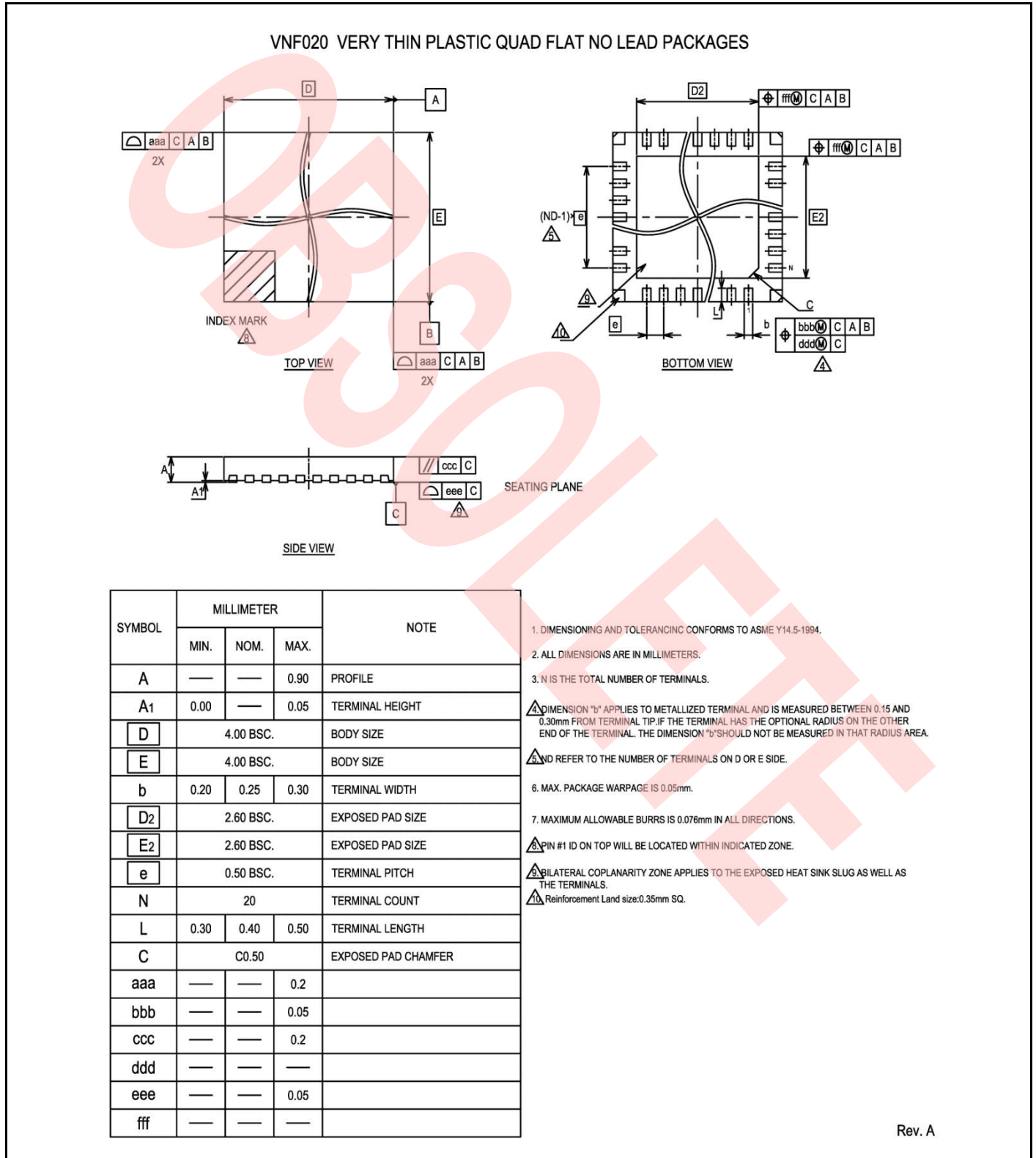
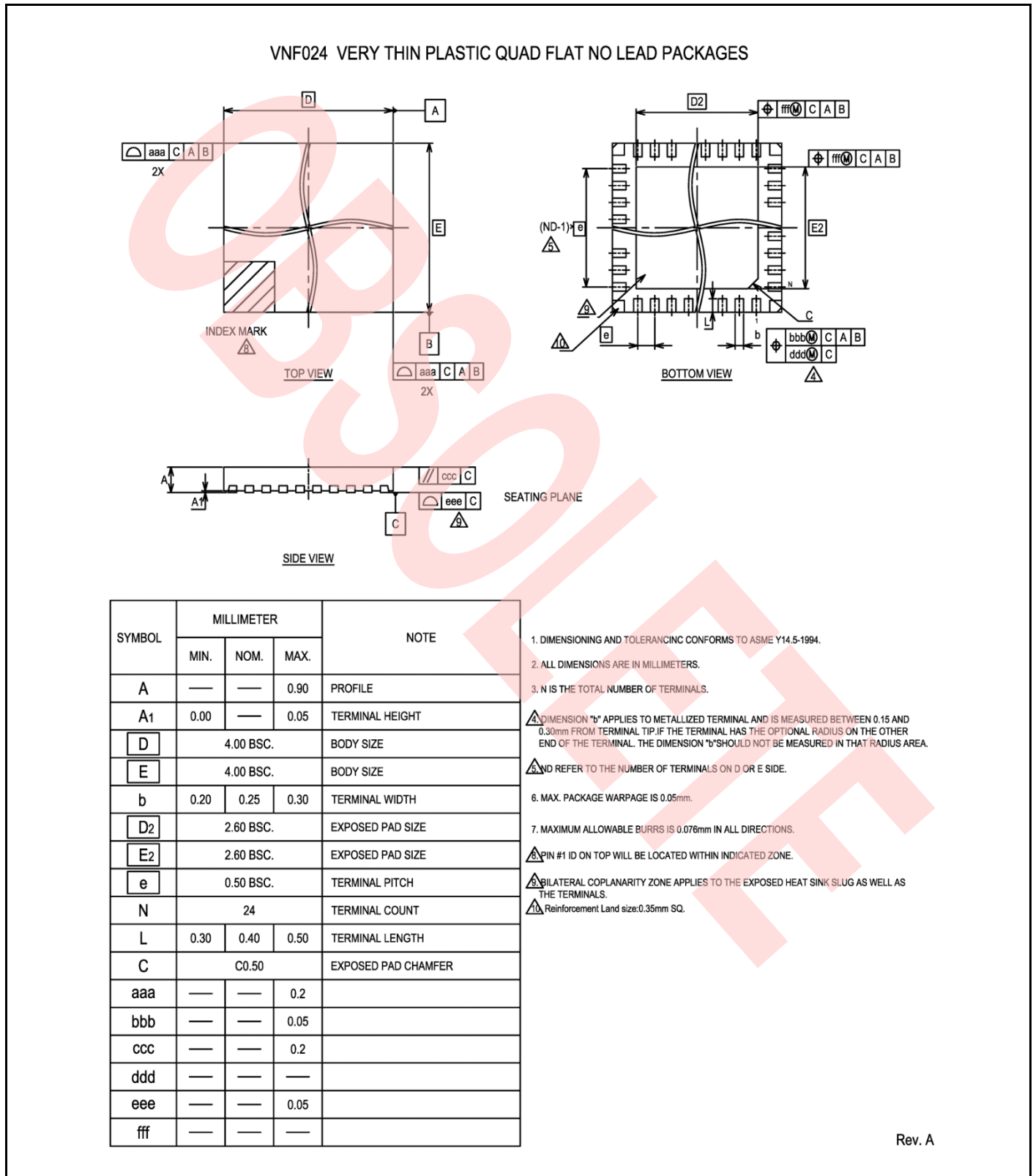

Figure 17-2 Package Dimensions of S6AE103A (VNF024)



### 18. Major Changes

Page	Section	Change Results
Preliminary 0.1		
-	-	Initial release
Preliminary 0.2		
-	-	Typo error correction

**NOTE: Please see “Document History” about later revised information.**

### Document History

**Document Title: S6AE102A/S6AE103A Energy Harvesting PMIC for Wireless Sensor Node**

**Document Number: 002-08501**

Revision	ECN	Orig. of Change	Submission Date	Description of Change
**	-	TAOA	07/31/2015	New Spec.
*A	5042720	TAOA	12/11/2015	Updated <a href="#">5. Architecture Block Diagram</a> Updated <a href="#">7. Recommended Operating Conditions</a> Updated <a href="#">8. Electrical Characteristics</a> Updated <a href="#">10. Application Circuit Example and Parts list</a> Updated <a href="#">11. Application Note</a> : Changed the formula in “Setting of Timer Time”
*B	5106892	HIXT	01/26/2016	Added <a href="#">Block Diagram</a> Added <a href="#">Figure 4-1 S6AE102A / S6AE103A I/O Pin Equivalent Circuit Diagram</a> Updated <a href="#">5. Architecture Block Diagram</a> Added <a href="#">12. Development Support</a> Added <a href="#">13. Reference Data</a> Updated <a href="#">Table 16-1 Ordering Part Number</a> Added <a href="#">Figure 16-1 Ordering Part Number Definitions</a>
*C	5157075	HIXT	03/01/2016	Updated <a href="#">Block Diagram</a> Updated the description of VSTORE2 in <a href="#">Table 4-1</a> Updated <a href="#">5. Architecture Block Diagram</a> Updated the followings in <a href="#">7. Recommended Operating Conditions</a> Condition and values of V <sub>SYSH</sub> Updated and deleted the followings in <a href="#">Table 8-1</a> . Parameter, Condition and Value of V <sub>VST2H</sub> Deleted V <sub>VST2L</sub> Deleted the following in <a href="#">Table 8-3</a> Deleted R <sub>ON3</sub> Updated the descriptions in <a href="#">9.1 Power Supply Control</a> Updated <a href="#">Figure 9-4</a> Updated the descriptions in <a href="#">VSTORE2 Input Power Operation (VSYSH ≥ 2.5V)</a> Updated <a href="#">Figure 9-5</a> Updated <a href="#">Figure 10-1, Figure 10-2 and Table 10-1</a>
*D	5688147	RUPA	04/18/2017	Updated Cypress logo. Updated Copyright information.
*E	7622463	ATTS	01/27/2022	Obsolete document. Completing Sunset Review.

## Sales, Solutions, and Legal Information

### Worldwide Sales and Design Support

Cypress maintains a worldwide network of offices, solution centers, manufacturer's representatives, and distributors. To find the office closest to you, visit us at [Cypress Locations](#).

#### Products

ARM® Cortex® Microcontrollers	<a href="http://cypress.com/arm">cypress.com/arm</a>
Automotive	<a href="http://cypress.com/automotive">cypress.com/automotive</a>
Clocks & Buffers	<a href="http://cypress.com/clocks">cypress.com/clocks</a>
Interface	<a href="http://cypress.com/interface">cypress.com/interface</a>
Internet of Things	<a href="http://cypress.com/iot">cypress.com/iot</a>
Memory	<a href="http://cypress.com/memory">cypress.com/memory</a>
Microcontrollers	<a href="http://cypress.com/mcu">cypress.com/mcu</a>
PSoC	<a href="http://cypress.com/psoc">cypress.com/psoc</a>
Power Management ICs	<a href="http://cypress.com/pmhc">cypress.com/pmhc</a>
Touch Sensing	<a href="http://cypress.com/touch">cypress.com/touch</a>
USB Controllers	<a href="http://cypress.com/usb">cypress.com/usb</a>
Wireless Connectivity	<a href="http://cypress.com/wireless">cypress.com/wireless</a>

#### PSoC® Solutions

[PSoC 1](#) | [PSoC 3](#) | [PSoC 4](#) | [PSoC 5LP](#) | [PSoC 6](#)

#### Cypress Developer Community

[Forums](#) | [WICED IOT Forums](#) | [Projects](#) | [Videos](#) | [Blogs](#) | [Training](#) | [Components](#)

#### Technical Support

[cypress.com/support](http://cypress.com/support)

ARM and Cortex are the registered trademarks of ARM Limited in the EU and other countries.

© Cypress Semiconductor Corporation, 2015-2022. This document is the property of Cypress Semiconductor Corporation and its subsidiaries, including Spansion LLC ("Cypress"). This document, including any software or firmware included or referenced in this document ("Software"), is owned by Cypress under the intellectual property laws and treaties of the United States and other countries worldwide. Cypress reserves all rights under such laws and treaties and does not, except as specifically stated in this paragraph, grant any license under its patents, copyrights, trademarks, or other intellectual property rights. If the Software is not accompanied by a license agreement and you do not otherwise have a written agreement with Cypress governing the use of the Software, then Cypress hereby grants you a personal, non-exclusive, nontransferable license (without the right to sublicense) (1) under its copyright rights in the Software (a) for Software provided in source code form, to modify and reproduce the Software solely for use with Cypress hardware products, only internally within your organization, and (b) to distribute the Software in binary code form externally to end users (either directly or indirectly through resellers and distributors), solely for use on Cypress hardware product units, and (2) under those claims of Cypress's patents that are infringed by the Software (as provided by Cypress, unmodified) to make, use, distribute, and import the Software solely for use with Cypress hardware products. Any other use, reproduction, modification, translation, or compilation of the Software is prohibited.

TO THE EXTENT PERMITTED BY APPLICABLE LAW, CYPRESS MAKES NO WARRANTY OF ANY KIND, EXPRESS OR IMPLIED, WITH REGARD TO THIS DOCUMENT OR ANY SOFTWARE OR ACCOMPANYING HARDWARE, INCLUDING, BUT NOT LIMITED TO, THE IMPLIED WARRANTIES OF MERCHANTABILITY AND FITNESS FOR A PARTICULAR PURPOSE. To the extent permitted by applicable law, Cypress reserves the right to make changes to this document without further notice. Cypress does not assume any liability arising out of the application or use of any product or circuit described in this document. Any information provided in this document, including any sample design information or programming code, is provided only for reference purposes. It is the responsibility of the user of this document to properly design, program, and test the functionality and safety of any application made of this information and any resulting product. Cypress products are not designed, intended, or authorized for use as critical components in systems designed or intended for the operation of weapons, weapons systems, nuclear installations, life-support devices or systems, other medical devices or systems (including resuscitation equipment and surgical implants), pollution control or hazardous substances management, or other uses where the failure of the device or system could cause personal injury, death, or property damage ("Unintended Uses"). A critical component is any component of a device or system whose failure to perform can be reasonably expected to cause the failure of the device or system, or to affect its safety or effectiveness. Cypress is not liable, in whole or in part, and you shall and hereby do release Cypress from any claim, damage, or other liability arising from or related to all Unintended Uses of Cypress products. You shall indemnify and hold Cypress harmless from and against all claims, costs, damages, and other liabilities, including claims for personal injury or death, arising from or related to any Unintended Uses of Cypress products.

Cypress, the Cypress logo, Spansion, the Spansion logo, and combinations thereof, WICED, PSoC, CapSense, EZ-USB, F-RAM, and Traveo are trademarks or registered trademarks of Cypress in the United States and other countries. For a more complete list of Cypress trademarks, visit [cypress.com](http://cypress.com). Other names and brands may be claimed as property of their respective owners.