



## **CeraPlas Element**

### Piezoelectric Based Cold Plasma Generator

**Series/Type:** HF series  
**Ordering code:** Z63000Z2910Z 1Z60  
**Date:** 2019-08-05  
**Version:** 3

## Preliminary data

### Features

- Direct high voltage discharge unit for generation of plasma
  - No high voltage wiring
  - No high voltage plugs
  - Ready to use with TDK CeraPlas™ driving stage
- High ionization rate and efficient ozone generation rate
- Multi gas ignition
- Low power
- High efficiency
- No magnetic fields
- Package design ready for easy assembly
- Evaluation-Kit available: Ordering code Z63000Z2910Z 1Z61  
For initial tests, application trials and small series applications, the use of the TDK CeraPlas driving stage is strongly recommended.

### Application fields

- Ionization of various gases at atmospheric pressure and ambient temperature conditions
- Non-thermal atmospheric pressure plasma generation
- Smell reduction and decontamination of air
- Surface treatment processing like activation, cleaning and purifying

### Applications

- Integration in ionization or plasma generating modules
- Implementation in handheld and plug connected devices

### Construction

- RoHS compatible PZT ceramic
- Plastic package
- Solderable Cu/Ag wires

Preliminary data

Dimensional drawings

Material: PBT GF30

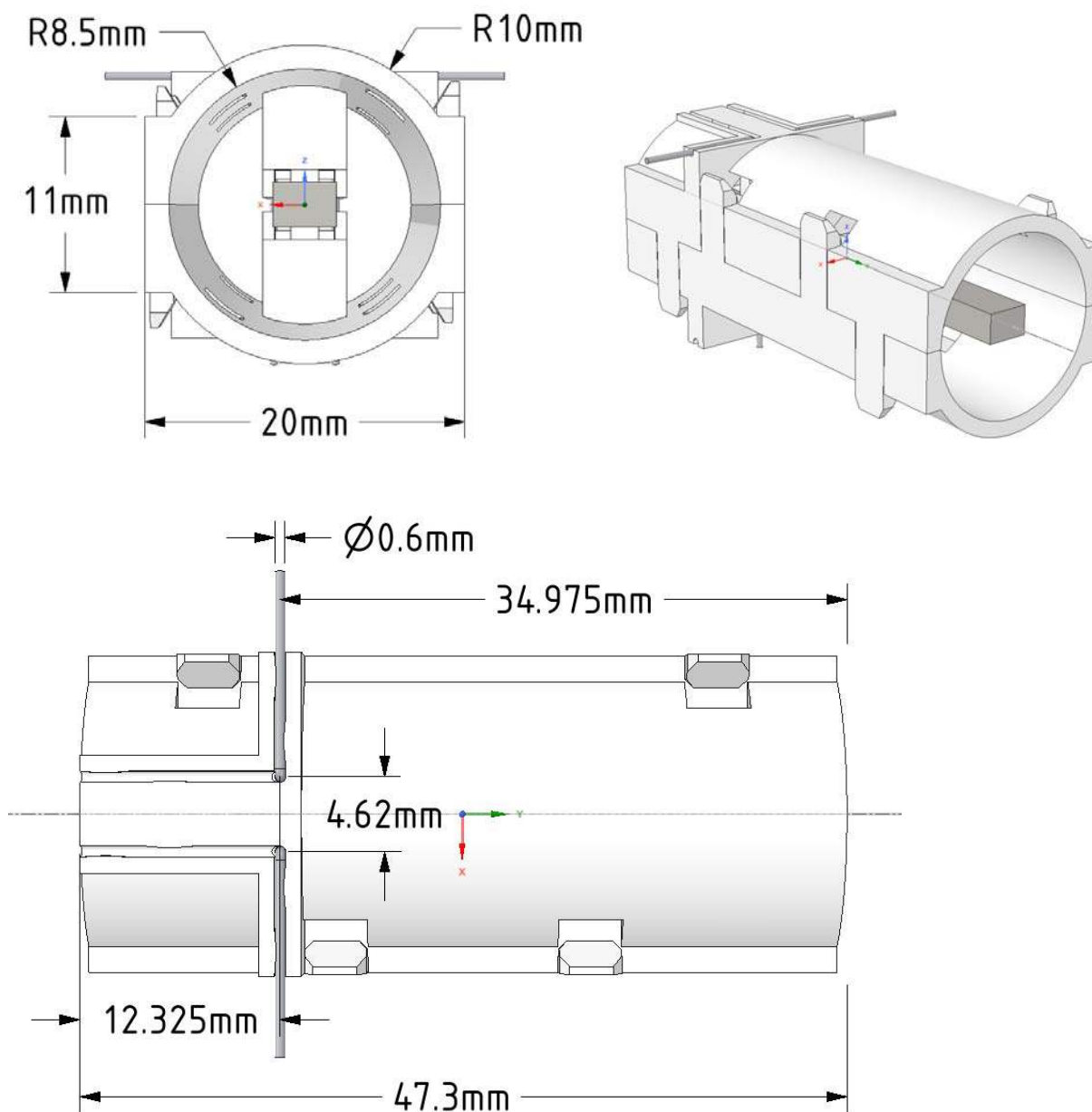

**Notes: Material and dimensions under development.  
Changes without notification!**

**Preliminary data**
**Specification**

<b>Material type and features</b>	Piezoelectric high coupling High stiffness High stability of mechanical quality factor
<b>Excitation waveform for operation</b>	Sinusoidal wave

Parameter	Symbol	Value	Unit
Maximum voltage for continuous operation	$V_{in}$	7	V <sup>1)</sup>
Maximum continuous operation input power	$P_{in}$	typ. 5 <sup>2)</sup>	W
Operating frequency (2 <sup>nd</sup> harmonic anti-resonance)	$f_{res \text{ typ.}}$	82	kHz
Typical input capacitance @ $V_{in} = 0.1 \text{ V}$ , 1 kHz, 25 °C	$C_{in}$	0.74	μF
Operating temperature range	$T_{op}$	0 ... +60	°C
Max. temperature on CeraPlas	$T_{max}$	+85	°C
Weight	$m \text{ approx.}$	3.8	g

Tolerances to be qualified; Performance to be qualified

- 1) Unless otherwise noted voltages and currents are rated in RMS-values
- 2) Strongly influenced by cooling efficiency of CeraPlas element

Preliminary data

Input impedance in dependence on frequency ( $T_{\text{device}} = +25\text{ }^{\circ}\text{C}$ )

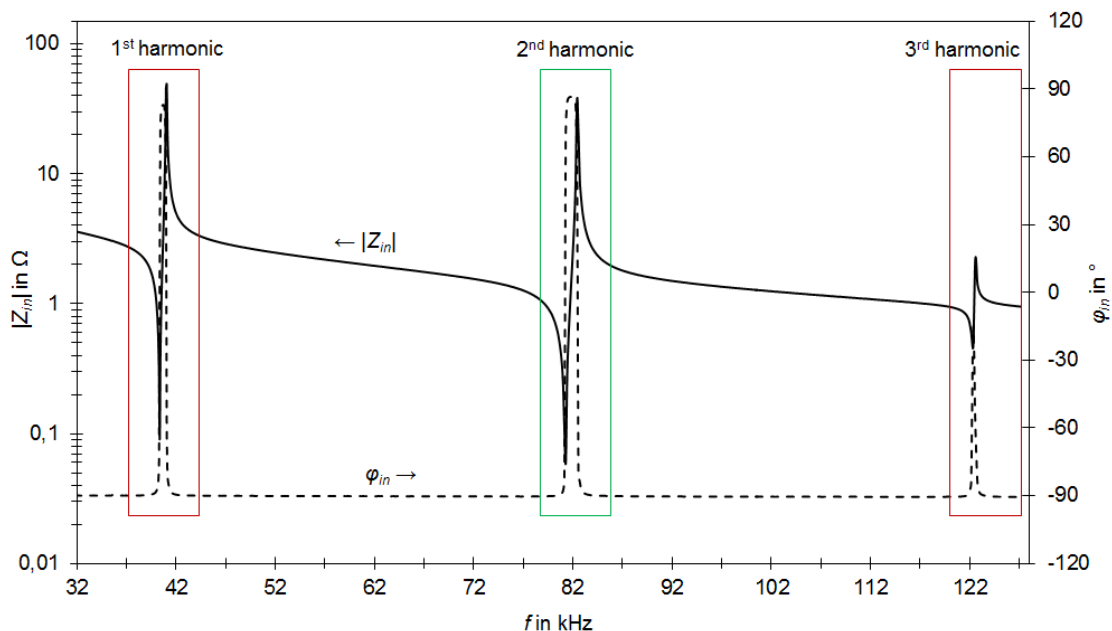

Fig. 1. Typical input impedance at open-circuit output ( $V_{\text{in}} = 0.1\text{ V}$ , no plasma).

The CeraPlas element has its first resonance around 41 kHz. It is designed to be driven at its 2<sup>nd</sup> harmonic around 82 kHz, shown in detail in Fig. 2.

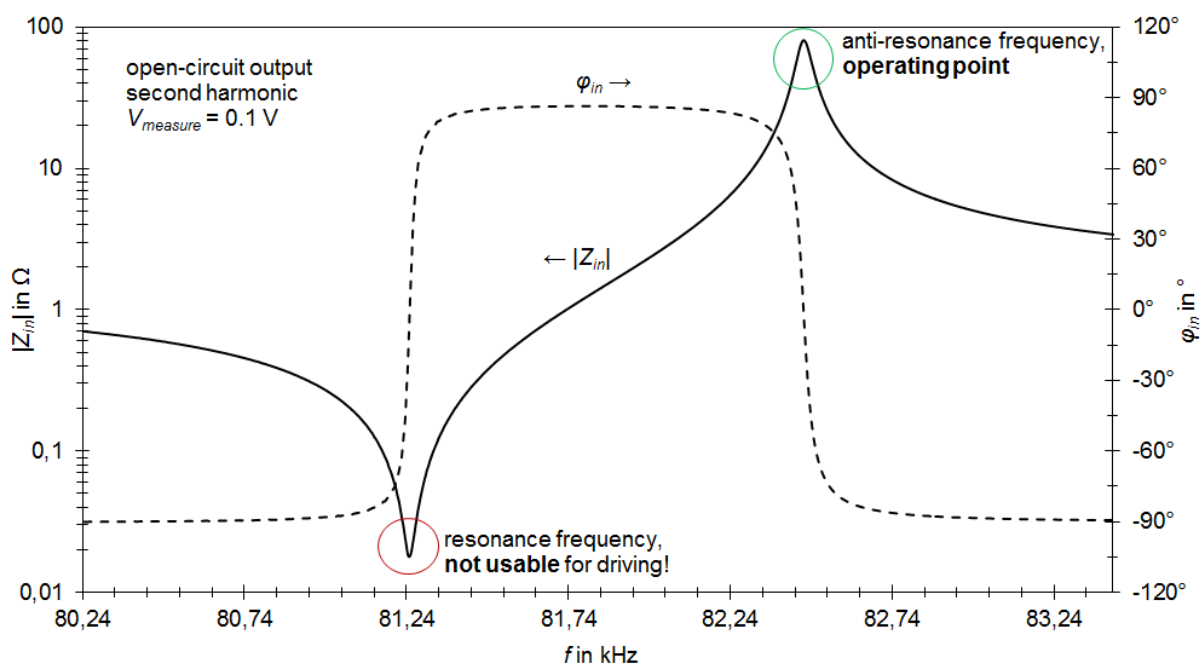

Fig. 2. Typical input impedance around 2<sup>nd</sup> harmonic at open-circuit output ( $V_{\text{in}} = 0.1\text{ V}$ , no plasma).

**Preliminary data**

At resonance frequency the impedance is close to the minimum, at anti-resonance the impedance is close to the maximum. In both cases the phase is 0°. The CeraPlas element is designed to be driven at the 2<sup>nd</sup> harmonic anti-resonance frequency/maximum impedance. Driving at resonance frequency/minimum impedance has to be avoided.

**Input impedance in dependence on input voltage**

By increasing the input voltage at 2<sup>nd</sup> harmonic anti-resonance frequency the output voltage increases. At a distinct threshold input voltage the output voltage is sufficient to start ignition of plasma, visible as small plasma dots at the corners of the output. The ignition of plasma presents a load at the output of the CeraPlas element. Thus, the load at the output depends on the input voltage. The load widely depends on the operating gas and environmental conditions, too. It is not possible to measure plasma impedance without influencing the output electric field. Nevertheless, to get an impression about how the load is changing the resonance behavior a simulation of resonance curves for different loads is depicted in Fig. 3. Be aware that the resonance frequencies are shifted with varying loads!

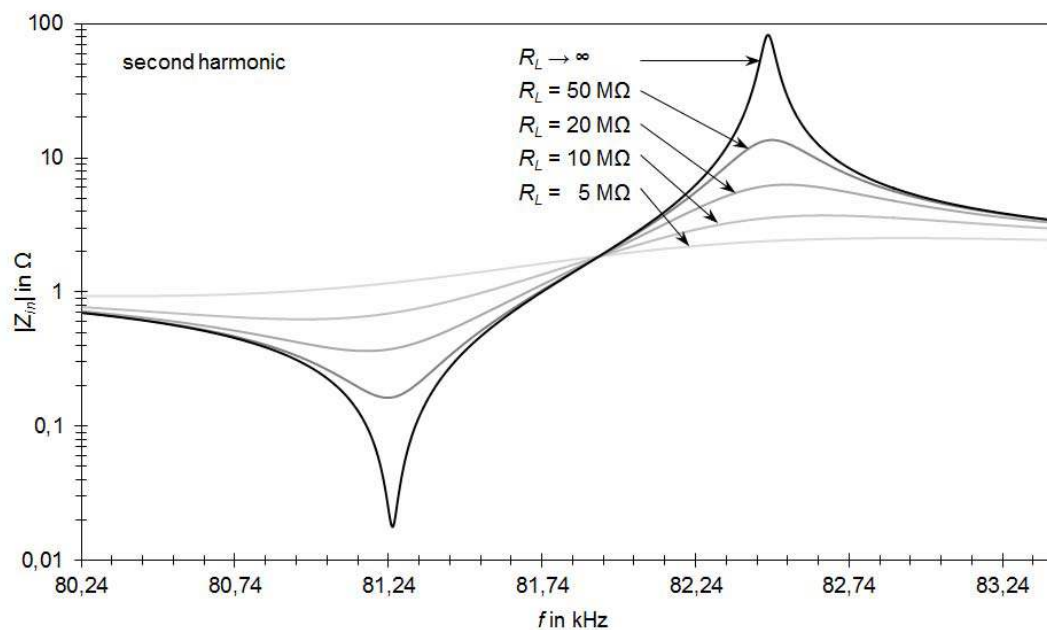

**Fig. 3.** Simulated input impedance for different loads  $R_L$ .

**Input voltage selection**

Due to the variations in the substrate material, operating gases, environmental conditions, and set-up arrangements it is not possible to define a definite input voltage for plasma generation.

In order to find an input voltage that satisfies the application’s requirements start with low voltages and increase the voltage step by step. For every step re-adjust the frequency to find anti-resonance. This procedure is limited by the temperature and maximum power capabilities of the CeraPlas element. The CeraPlas element can then be operated between ignition threshold and maximum temperature/power conditions (see page 4). A typical threshold voltage can be clearly seen as jump towards lower impedance.

**Preliminary data**
**Driving at maximum efficiency**

It is recommended to drive the CeraPlas elements at maximum efficiency under all conditions to avoid overheating. Depending on applied power the maximum efficiency is located at two different conditions:

1. Input power between 1.5 W and 5 W: Plasma is changing the input impedance. Maximum impedance does not correspond with  $0^\circ$  anymore. Maximum efficiency is located at  $0^\circ$ . At maximum impedance the efficiency is lower.
2. Input power  $> 5$  W (not recommended for continuous operation): A phase of  $0^\circ$  cannot be found anymore. In this case the maximum efficiency will be located at a frequency where the (in this case always negative phase) absolute value of the phase shows a minimum.

The controlling criteria for operation at maximum efficiency are given in Table 2.

**Table 2:** Controlling criteria for driving the CeraPlas elements at maximum efficiency.

<b>Pin</b>	<b>Criterion</b>
$< 5$ W	$\varphi_{in} = 0^\circ, \approx \max Z_{in} $
$\geq 5$ W	$\min \varphi_{in} , \neq \max Z_{in} $

Therefore, mainly two frequency controlling techniques can be used:

1. **Current-controlled:** voltage is given, frequency at minimum current is used. Simple solution, works fine at low powers, high losses at higher powers.
2. **Phase-controlled:** voltage is given, frequency is changed by decreasing  $\Delta f$  until  $\Delta\varphi/\Delta f \approx 0$ . Complex solution, phase has to be measured. Works fine at any powers.

## Preliminary data

### Cautions and warnings

#### General

Some parts of this publication contain statements about the suitability of our ceramic multilayer Piezo components (CeraPlas) for certain areas of application, including recommendations about incorporation/design-in of these products into customer applications. The statements are based on our knowledge of typical requirements made of our devices in the particular areas. We nevertheless expressly point out that such statements cannot be regarded as binding statements about the suitability of our CeraPlas elements for a particular customer application. As a rule, TDK is either unfamiliar with individual customer applications or less familiar with them than the customers themselves. For these reasons, it is always incumbent on the customer to check and decide whether the CeraPlas elements with the properties described in the product specification are suitable for use in a particular customer application.

- Do not use CeraPlas elements for purposes not identified in our specifications, application notes and data books.
- Ensure the suitability of a CeraPlas element in particular by testing it for reliability during design-in. Always evaluate a CeraPlas element under worst-case conditions.
- Pay special attention to the reliability of CeraPlas elements intended for use in safety-critical applications (e.g. medical equipment, automotive, spacecraft, nuclear power plant).

#### Design notes

- Always connect a CeraPlas element with the electronic driving circuit.
- Consider maximum rated power dissipation if a CeraPlas element has insufficient time to cool down between a numbers of pulses occurring within a specified isolated time period. Ensure that surface temperature does not exceed maximum operating temperature and that electrical characteristics do not degrade.
- Consider derating at higher operating temperatures.
- Surge currents beyond specified values will puncture a CeraPlas element. In extreme cases a CeraPlas element will rupture.
- If steep surge current edges are to be expected, make sure your design is as low-inductive as possible.
- In some cases the malfunctioning of passive electronic components or failure before the end of their service life cannot be completely ruled out in the current state of the art, even if they are operated as specified. In applications requiring a very high level of operational safety and especially when the malfunction or failure of a passive electronic component could endanger human life or health (e.g. in accident prevention, life-saving systems, or automotive battery line applications such as clamp 30), ensure by suitable design of the application or other measures (e.g. installation of protective circuitry or redundancy) that no injury or damage is sustained by third parties in the event of such a malfunction or failure. Do not use CeraPlas elements in safety-relevant applications.
- Specified values only apply to CeraPlas elements that have not been subject to prior electrical, mechanical or thermal damage.

#### Storage

- Only store CeraPlas elements in their original packaging. Do not open the package before storage.
- Storage conditions in original packaging: temperature  $-25$  to  $+45$  °C, relative humidity  $\leq 75\%$  annual average, maximum  $95\%$  on 30 days a year and dew precipitation is inadmissible.
- Do not store CeraPlas elements where they are exposed to heat or direct sunlight. Otherwise the packaging material may be deformed or CeraPlas elements may stick together, causing problems during mounting.
- Avoid contamination of the CeraPlas elements surface during storage, handling and processing.



### Preliminary data

- Avoid storing CeraPlas elements in harmful environments where they are exposed to corrosive gases (for example SO<sub>x</sub>, Cl).
- Use CeraPlas elements as soon as possible after opening factory seals such as polyvinyl-sealed packages.
- Solder CeraPlas elements after shipment from TDK within 12 months.

### Handling

- Do not drop CeraPlas elements and allow them to be chipped.
- Do not touch CeraPlas elements with your bare hands - gloves are recommended.
- Avoid contamination of the CeraPlas element surface during handling.
- Do not touch CeraPlas elements during operation (danger of high voltage, damping the acoustic wave inside the ceramic body, damaging the ceramic body).

### Mounting

- Do not encapsulate with sealing material or overmould CeraPlas elements with plastic material to prevent a damping of the device's vibrations.
- Do not put the package of the CeraPlas under pressure and do not deform the package to prevent a damping of the device's vibrations.
- Make sure contacts and housings used for assembly with CeraPlas elements are clean before mounting.
- The surface temperature of an operating CeraPlas element can be higher. Ensure that adjacent components are placed at a sufficient distance from a CeraPlas element to allow proper cooling.
- Avoid contamination of the CeraPlas element surface during processing.
- For mounting of the package element take special precautions for isolating properties of the used materials (NO CONDUCTIVE MATERIALS on plasma generating side).
- Prevent any damping of the vibrations due to any clamping of the CeraPlas element.

### Soldering

- Iron soldering process is recommended for contacting of the wires
- The recommended electrical contacting of CeraPlas elements are
  - soldering of the wires on PCB
  - soldering of conductive wires with diameter > 0.6 mm
- Device is not designed for reflow soldering and vapour phase soldering.
- The temperature of housing shall not exceed +60 °C.
- Rapid cooling by dipping in solvent is not recommended, otherwise a component may crack.

### Operation

- Use CeraPlas element only within the specified operating temperature range.
- Use CeraPlas element only within specified voltage and power ranges.
- Use CeraPlas element only within the specified frequency range.
- The CeraPlas element has to be operated in a dry atmosphere which must not contain any additional chemical vapour or substances.
- Environmental conditions must not harm a CeraPlas element. Only use them in normal atmospheric conditions.
- Prevent a CeraPlas element from contacting liquids and solvents. Make sure that no water enters a CeraPlas element.

**Preliminary data**

- Avoid dewing and condensation.
- CeraPlas elements are mainly designed for encased applications. Under all circumstances avoid exposure to:
  - direct sunlight
  - rain or condensation
  - steam, saline spray
  - corrosive gases
  - atmosphere with reduced oxygen content
- Avoid electrical conducting materials near the output side of the CeraPlas element.

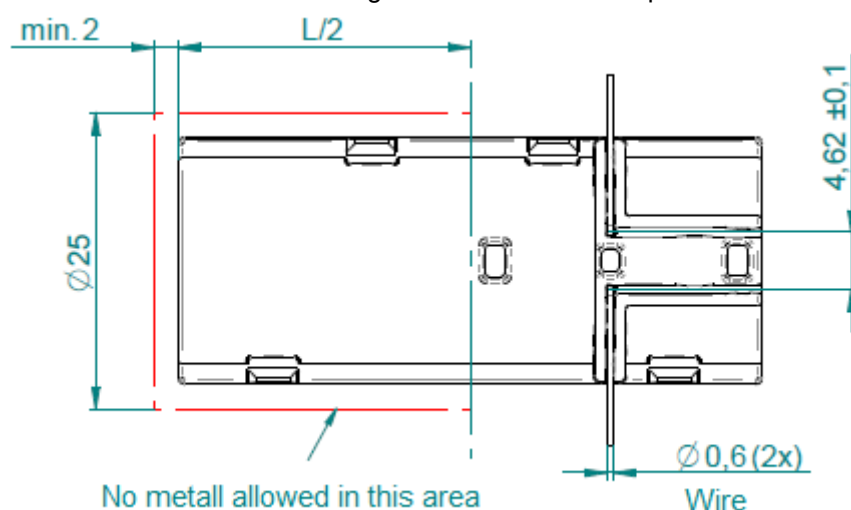

- Discharging towards an electrical conducting material near the output side of the transformer can lead to overheating of the CeraPlas element even if the load is isolated.
- High voltage hazard! The output side of the CeraPlas element can reach voltages of up to 10 kV!
- Take special care of the toxicity of ozone! Use a ventilation system to remove the ozone. Depending on air-flow around the output of the transformer the ozone concentration can reach very high values!
- Use air or inert gases only! Do not use flammable working gases!
- TDK is not responsible for any harm during operating and testing of CeraPlas elements!

This listing does not claim to be complete, but merely reflects the experience of TDK.

**Display of ordering codes for TDK Electronics products**

The ordering code for one and the same product can be represented differently in data sheets, data books, other publications, on the company website, or in order-related documents such as shipping notes, order confirmations and product labels. **The varying representations of the ordering codes are due to different processes employed and do not affect the specifications of the respective products.** Detailed information can be found on the Internet under [www.tdk-electronics.tdk.com/orderingcodes](http://www.tdk-electronics.tdk.com/orderingcodes).

## Important notes

The following applies to all products named in this publication:

1. Some parts of this publication contain **statements about the suitability of our products for certain areas of application**. These statements are based on our knowledge of typical requirements that are often placed on our products in the areas of application concerned. We nevertheless expressly point out **that such statements cannot be regarded as binding statements about the suitability of our products for a particular customer application**. As a rule we are either unfamiliar with individual customer applications or less familiar with them than the customers themselves. For these reasons, it is always ultimately incumbent on the customer to check and decide whether a product with the properties described in the product specification is suitable for use in a particular customer application.
2. We also point out that **in individual cases, a malfunction of electronic components or failure before the end of their usual service life cannot be completely ruled out in the current state of the art, even if they are operated as specified**. In customer applications requiring a very high level of operational safety and especially in customer applications in which the malfunction or failure of an electronic component could endanger human life or health (e.g. in accident prevention or life-saving systems), it must therefore be ensured by means of suitable design of the customer application or other action taken by the customer (e.g. installation of protective circuitry or redundancy) that no injury or damage is sustained by third parties in the event of malfunction or failure of an electronic component.
3. **The warnings, cautions and product-specific notes must be observed.**
4. In order to satisfy certain technical requirements, **some of the products described in this publication may contain substances subject to restrictions in certain jurisdictions (e.g. because they are classed as hazardous)**. Useful information on this will be found in our Material Data Sheets on the Internet ([www.tdk-electronics.tdk.com/material](http://www.tdk-electronics.tdk.com/material)). Should you have any more detailed questions, please contact our sales offices.
5. We constantly strive to improve our products. Consequently, **the products described in this publication may change from time to time**. The same is true of the corresponding product specifications. Please check therefore to what extent product descriptions and specifications contained in this publication are still applicable before or when you place an order.

We also **reserve the right to discontinue production and delivery of products**. Consequently, we cannot guarantee that all products named in this publication will always be available. The aforementioned does not apply in the case of individual agreements deviating from the foregoing for customer-specific products.

6. Unless otherwise agreed in individual contracts, **all orders are subject to our General Terms and Conditions of Supply**.
7. **Our manufacturing sites serving the automotive business apply the IATF 16949 standard**. The IATF certifications confirm our compliance with requirements regarding the quality management system in the automotive industry. Referring to customer requirements and customer specific requirements ("CSR") TDK always has and will continue to have the policy of respecting individual agreements. Even if IATF 16949 may appear to support the acceptance of unilateral requirements, we hereby like to emphasize that **only requirements mutually agreed upon can and will be implemented in our Quality Management System**. For clarification purposes we like to point out that obligations from IATF 16949 shall only become legally binding if individually agreed upon.

## Important notes

8. The trade names EPCOS, CeraCharge, CeraDiode, CeraLink, CeraPad, CeraPlas, CSMP, CTVS, DeltaCap, DigiSiMic, ExoCore, FilterCap, FormFit, LeaXield, MiniBlue, MiniCell, MKD, MKK, MotorCap, PCC, PhaseCap, PhaseCube, PhaseMod, PhiCap, PowerHap, PQSine, PQvar, SIFERRIT, SIFI, SIKOREL, SilverCap, SIMDAD, SiMic, SIMID, SineFormer, SIOV, ThermoFuse, WindCap are **trademarks registered or pending** in Europe and in other countries. Further information will be found on the Internet at [www.tdk-electronics.tdk.com/trademarks](http://www.tdk-electronics.tdk.com/trademarks).

Release 2018-10