

SPECIFICATION CONTROL DRAWING	4126S5664
--------------------------------------	------------------

CHEMINAX	41 OHM, AWG 26, 19 STRANDS OF AWG 38, TRIAxIAL CABLE, OUTER SPACE USE	Date	12-31-08
		Revision	F

THIS SPECIFICATION SHEET FORMS A PART OF THE LATEST ISSUE OF RAYCHEM SPECIFICATION 1200.

CONSTRUCTION DETAILS	ELECTRICAL CHARACTERISTICS
-----------------------------	-----------------------------------

DIMENSIONS ARE NOMINAL VALUES IN INCHES UNLESS OTHERWISE DESIGNATED.

CHARACTERISTIC IMPEDANCE	41.6 ± 2 ohms, Method A
CAPACITANCE	40.6 pF/ft. (nominal)

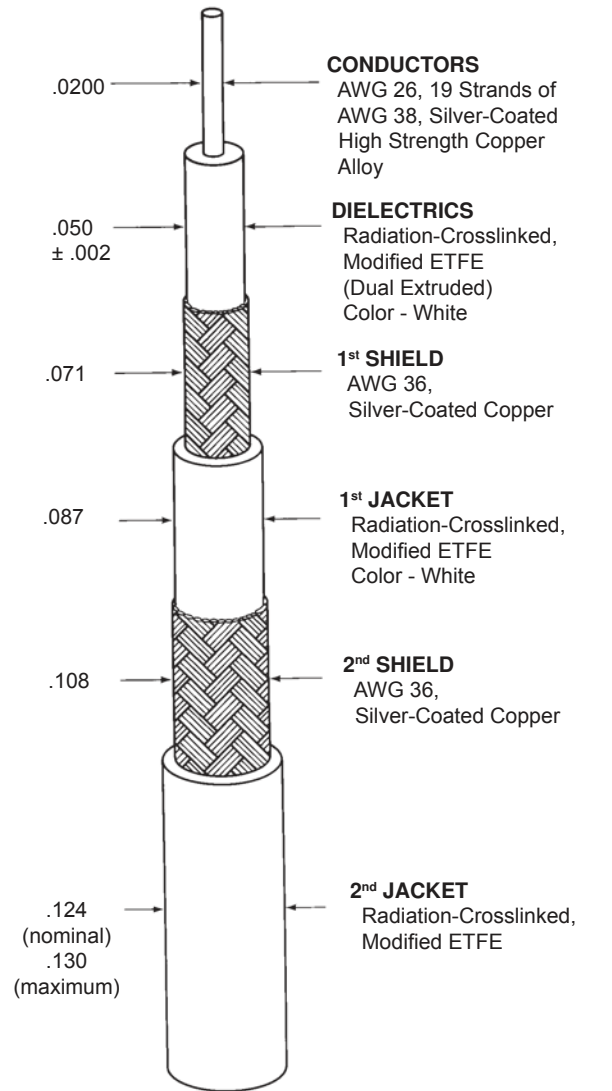

ADDITIONAL REQUIREMENTS

COMPONENT WIRE PRIOR TO BRAIDING (Test Procedures per SAE AS22759)	
CROSSLINK PROOF	300 ± 3°C for 1 hour, .625 inch mandrel, .500 lb., 2.5 kV dielectric test
INSULATION (DIELECTRIC) (Total Insulation)	50% (minimum)
ELONGATION	5000 lbf/in ² (minimum)
TENSILE STRENGTH	5000 megohms for 1000 ft. (minimum)
INSULATION FLAWS	
SPARK TEST	3.0 kV (rms)
IMPULSE TEST	8.0 kV (peak)
INSULATION RESISTANCE	5000 megohms for 1000 ft. (minimum)
LOW TEMPERATURE-COLD BEND	-65 ± 3°C for 4 hours, .500 inch mandrel, .500 lb., 2.5 kV dielectric test
SHRINKAGE	200 ± 3°C for 1 hour, .125 inch (maximum) in 12 inches

FINISHED CABLE (Test Procedures per NEMA WC 27500, unless otherwise specified)	
---	--

BLOCKING	200°C for 6 hours
CROSSLINKED VERIFICATION	300 ± 5°C for 6 hours, 3.00 inch mandrel
FLAMMABILITY (Method B of Spec 1200)	3 seconds (maximum); 3 inches (maximum); no flaming of facial tissue
JACKET (each)	
ELONGATION	50% (minimum)
TENSILE STRENGTH	5000 lbf/in ² (minimum)
JACKET FLAWS	
SPARK TEST	1.0 kV (rms)
IMPULSE TEST	6.0 kV (peak)
JACKET THICKNESS (each)	.008 inch (nominal)
LOW TEMPERATURE-COLD BEND	-55 ± 5°C for 4 hours, 3.00 inch mandrel
SHIELD COVERAGE (each)	90% (minimum)
VOLTAGE WITHSTAND	
CONDUCTOR TO SHIELD	1500 volts (rms)
SHIELD TO SHIELD	500 volts (rms)
WEIGHT	16.7 lbs/1000 ft. (nominal)

OUTER SPACE REQUIREMENTS	
---------------------------------	--

RADIATION RESISTANCE	500 megarads/3.75 inch mandrel 1.0 kV dielectric test
VACUUM STABILITY	
TOTAL MASS LOSS (TML)	1.00% (maximum)
VOLATILE CONDENSABLE MATERIAL (VCM)	0.10% (maximum)
WEIGHT LOSS (Test per Spec 55):	0.45% (maximum)

Outer jacket color will be white (designated by a "-9" appended to the part number, e.g. 4126S5664-9) unless otherwise specified.

Designate outer jacket color with a dash number in accordance with MIL-STD-681. Other codes and suffixes may be added to the part number, as necessary, to capture any additional requirements imposed by the purchase order.

Users should evaluate the suitability of this product for their application. Specifications are subject to change without notice. Tyco Electronics also reserves the right to make changes in materials or processing, which do not affect compliance with any specification, without notification to Buyer.