

EVAL-M1-IM828-A user guide

Modular application design kit (MADK) of IM828-XCC

About this document

Scope and purpose

This user guide provides an overview of the evaluation board EVAL-M1-IM828-A including its main features, key data, pin assignments and mechanical dimensions.

EVAL-M1-IM828-A is a power evaluation board from the MADK including M1 connector and one CIPOS™ Maxi 1200 V three-phase module for motor drive applications. In combination with either EVAL-M1-101T or other control boards with compatible M1 connectors, it features and demonstrates Infineon's CIPOS™ Maxi IPM technology for motor drives.

The evaluation board EVAL-M1-IM828-A was developed to support customers during their first steps designing applications with IM828-XCC CIPOS™ Maxi power modules.

Intended audience

This user guide is intended for all technical specialists who know motor control, middle- and low-power electronics converters. The board is intended to be used under laboratory conditions.

Evaluation Board

This board will be used during design-in, for evaluation and measurement of characteristics, and proof of data sheet specifications.

Note: PCB and auxiliary circuits are NOT optimized for final customer design.

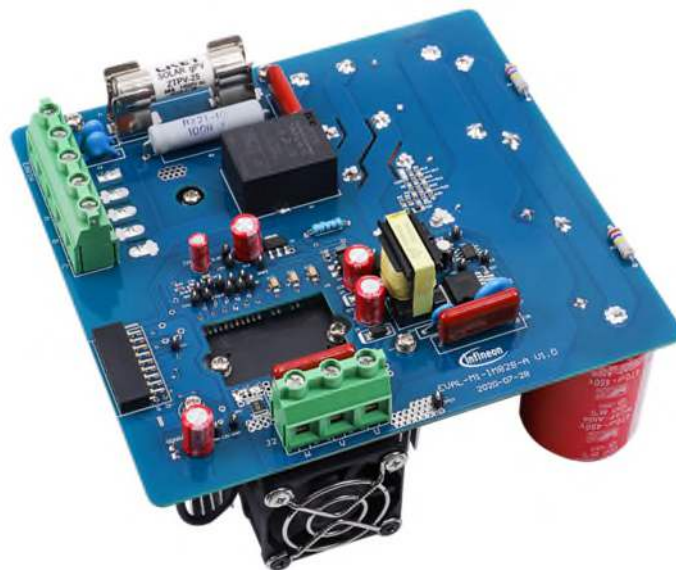

Important notice

Important notice

“Evaluation Boards and Reference Boards” shall mean products embedded on a printed circuit board (PCB) for demonstration and/or evaluation purposes, which include, without limitation, demonstration, reference and evaluation boards, kits and design (collectively referred to as “Reference Board”).

Environmental conditions have been considered in the design of the Evaluation Boards and Reference Boards provided by Infineon Technologies. The design of the Evaluation Boards and Reference Boards has been tested by Infineon Technologies only as described in this document. The design is not qualified in terms of safety requirements, manufacturing and operation over the entire operating temperature range or lifetime.

The Evaluation Boards and Reference Boards provided by Infineon Technologies are subject to functional testing only under typical load conditions. Evaluation Boards and Reference Boards are not subject to the same procedures as regular products regarding returned material analysis (RMA), process change notification (PCN) and product discontinuation (PD).

Evaluation Boards and Reference Boards are not commercialized products, and are solely intended for evaluation and testing purposes. In particular, they shall not be used for reliability testing or production. The Evaluation Boards and Reference Boards may therefore not comply with CE or similar standards (including but not limited to the EMC Directive 2004/EC/108 and the EMC Act) and may not fulfill other requirements of the country in which they are operated by the customer. The customer shall ensure that all Evaluation Boards and Reference Boards will be handled in a way which is compliant with the relevant requirements and standards of the country in which they are operated.

The Evaluation Boards and Reference Boards as well as the information provided in this document are addressed only to qualified and skilled technical staff, for laboratory usage, and shall be used and managed according to the terms and conditions set forth in this document and in other related documentation supplied with the respective Evaluation Board or Reference Board.

It is the responsibility of the customer’s technical departments to evaluate the suitability of the Evaluation Boards and Reference Boards for the intended application, and to evaluate the completeness and correctness of the information provided in this document with respect to such application.

The customer is obliged to ensure that the use of the Evaluation Boards and Reference Boards does not cause any harm to persons or third party property.

The Evaluation Boards and Reference Boards and any information in this document is provided "as is" and Infineon Technologies disclaims any warranties, express or implied, including but not limited to warranties of non-infringement of third party rights and implied warranties of fitness for any purpose, or for merchantability.

Infineon Technologies shall not be responsible for any damages resulting from the use of the Evaluation Boards and Reference Boards and/or from any information provided in this document. The customer is obliged to defend, indemnify and hold Infineon Technologies harmless from and against any claims or damages arising out of or resulting from any use thereof.

Infineon Technologies reserves the right to modify this document and/or any information provided herein at any time without further notice.

Safety precautions

Safety precautions

Note: Please note the following warnings regarding the hazards associated with development systems.

Table 1 Safety precautions

	<p>Warning: The DC link potential of this board is up to 800 V_{DC}. When measuring voltage waveforms by oscilloscope, high voltage differential probes must be used. Failure to do so may result in personal injury or death.</p>
	<p>Warning: The evaluation board contains DC bus capacitors which take time to discharge after removal of the main supply. Before working on the drive system, wait five minutes for capacitors to discharge to safe voltage levels. Failure to do so may result in personal injury or death. Darkened display LEDs are not an indication that capacitors have discharged to safe voltage levels.</p>
	<p>Warning: The evaluation board is connected to the grid input during testing. Hence, high-voltage differential probes must be used when measuring voltage waveforms by oscilloscope. Failure to do so may result in personal injury or death. Darkened display LEDs are not an indication that capacitors have discharged to safe voltage levels.</p>
	<p>Warning: Remove or disconnect power from the drive before you disconnect or reconnect wires, or perform maintenance work. Wait five minutes after removing power to discharge the bus capacitors. Do not attempt to service the drive until the bus capacitors have discharged to zero. Failure to do so may result in personal injury or death.</p>
	<p>Caution: The heat sink and device surfaces of the evaluation or reference board may become hot during testing. Hence, necessary precautions are required while handling the board. Failure to comply may cause injury.</p>
	<p>Caution: Only personnel familiar with the drive, power electronics and associated machinery should plan, install, commission and subsequently service the system. Failure to comply may result in personal injury and/or equipment damage.</p>
	<p>Caution: The evaluation board contains parts and assemblies sensitive to electrostatic discharge (ESD). Electrostatic control precautions are required when installing, testing, servicing or repairing the assembly. Component damage may result if ESD control procedures are not followed. If you are not familiar with electrostatic control procedures, refer to the applicable ESD protection handbooks and guidelines.</p>
	<p>Caution: A drive that is incorrectly applied or installed can lead to component damage or reduction in product lifetime. Wiring or application errors such as undersizing the motor, supplying an incorrect or inadequate AC supply, or excessive ambient temperatures may result in system malfunction.</p>
	<p>Caution: The evaluation board is shipped with packing materials that need to be removed prior to installation. Failure to remove all packing materials that are unnecessary for system installation may result in overheating or abnormal operating conditions.</p>

Table of contents

About this document	1
Important notice	2
Safety precautions	3
Table of contents	4
1 The board at a glance	5
1.1 Delivery content	5
1.2 Block diagram.....	5
1.3 Main features	6
1.4 Board parameters and technical data	6
2 System and functional description	8
2.1 Getting started with EVAL-M1-IM828-A.....	8
2.1.1 iMOTION™ control board	8
2.1.2 iMOTION™ development tools and software	9
2.1.3 MCEWizard setup overview.....	9
2.1.4 MCEDesigner setup overview.....	11
2.2 The current waveform from MCEDesigner	13
2.3 Description of the functional blocks.....	15
2.3.1 Overview of IM828-XCC	15
2.3.2 Overview of IMBF170R1K0M1	16
3 System design	18
3.1 Inverter section using CIPOS™ Maxi.....	18
3.2 DC/DC.....	18
3.3 AC/DC input and soft start	20
3.4 DC-link voltage measurement	20
3.5 Current sensing and amplifier	21
3.6 Current feedback to the control board.....	21
3.7 ITRIP and GK setup	24
3.7.1 ITRIP setup.....	24
3.7.2 PWM shut down and GK output.....	24
3.8 NTC thermistor characteristics and over-heat protection calculation	25
3.9 Layout	28
3.10 Bill of material	31
3.11 Connector details	32
4 System performance	34
4.1 Type output waveform at 3-phase AC380 V input.....	34
4.2 Test results for over-current protection	35
4.3 T_{cmaxi} vs I_{out} at different PWM frequencies	35
4.4 IM828-XCC's efficiency.....	36
5 References and appendices	37
5.1 Abbreviations and definitions.....	37
5.2 References	37
5.3 Additional information.....	37
Revision history	38

EVAL-M1-IM828-A user guide

Modular application design kit (MADK) of IM828-XCC

The board at a glance

1 The board at a glance

The EVAL-M1-IM828-A evaluation board is a part of the iMOTION™ MADK for motor control (iMOTION™ MADK).

The MADK platform is intended for use in various power stages with different control boards. These boards can easily be interfaced through the 20-pin iMOTION™ MADK-M1 interface connector.

This evaluation board is designed to give comprehensible solution for the power section featuring by CIPOST™ IPM. It provides a DC input and 3-phase output for power motor. It contains a single shunt for current sensing and a voltage divider for DC-link voltage measurement.

The EVAL-M1-IM828-A evaluation board is available from Infineon. The features of this board are described in the design feature chapter of this document (UG-2020-27), whereas the remaining paragraphs provide information to enable the customers to copy, modify and qualify the design for production according to their own specific requirements.

The evaluation boards are not subject to the same procedures as regular products regarding returned material analysis (RMA), process change notification (PCN) and product discontinuation (PD). Evaluation boards are intended to be used under laboratory conditions by technical specialists only.

1.1 Delivery content

The EVAL-M1-IM828-A evaluation board is designed to provide an ease-of-use power stage based on the Infineon's CIPOST™ Maxi intelligent power module (IM828-XCC IPM).

The delivery includes the finished board as shown in Figure 1 and Figure 2. It provides a 3-phase AC connector, an EMI filter and soft power-up circuit, input rectifier, DC bus capacitors and 3-phase output for connecting the motor.

It also contains quasi-resonant PWM controller and CoolSiC™ MOSFET based aux power supply to provide 15 V & 3.3 V, a single shunt for current sensing and over-current protection, and a voltage divider for DC-link voltage measurement. The board shown here can be operated directly with the required power supply without the need for additional components.

1.2 Block diagram

The block diagram of the EVAL-M1-IM828-A is depicted in Figure 1.

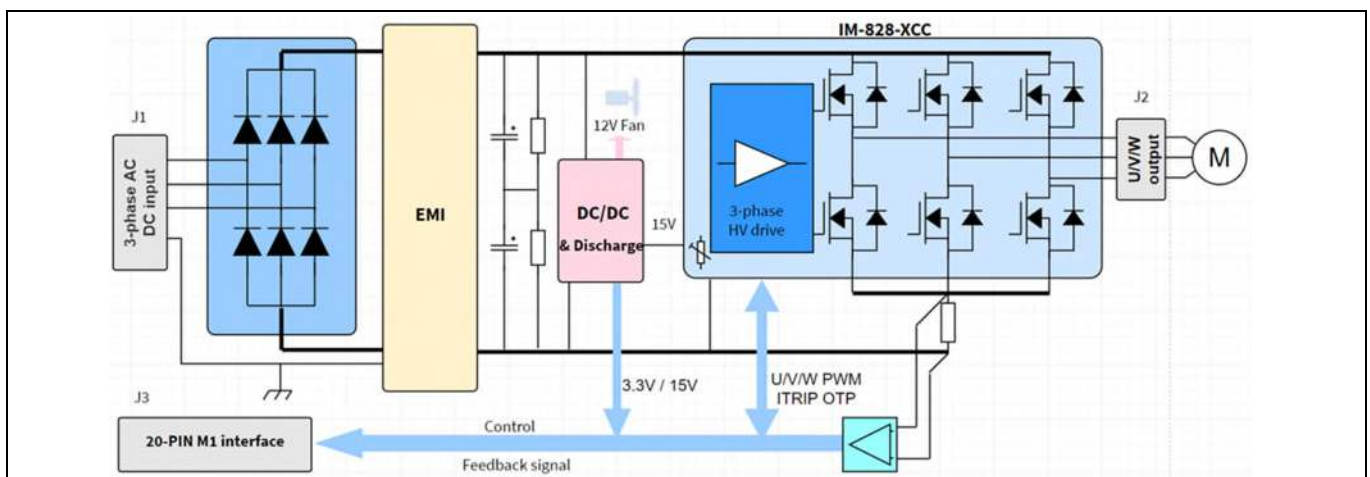

Figure 1 Block diagram of the EVAL-M1-IM828-A

EVAL-M1-IM828-A user guide

Modular application design kit (MADK) of IM828-XCC

The board at a glance

Figure 2 points out the functional groups on the top side of the EVAL-M1-IM828-A design.

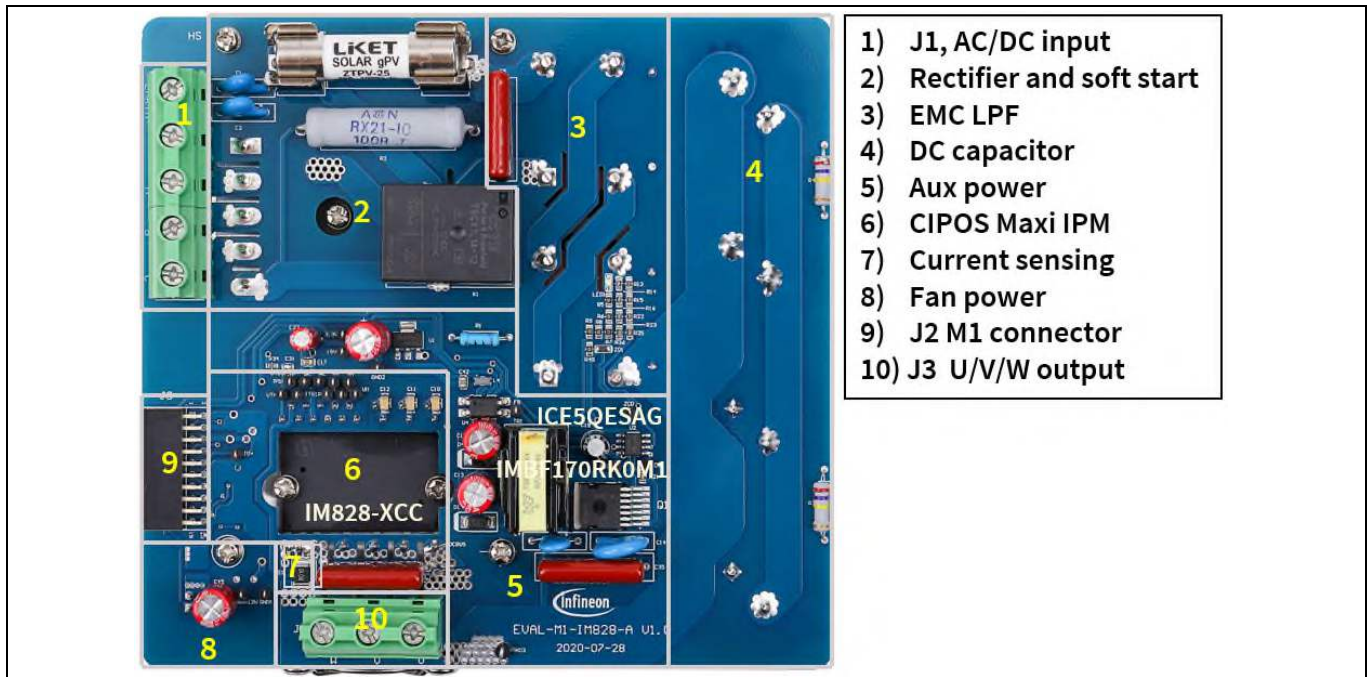

Figure 2 Functional groups of the EVAL-M1-IM828-A reference design

1.3 Main features

The evaluation board characteristics include:

- Nominal input voltage 3-phase 380 V AC
- Design for 8 kW motor power output
- On-board EMI filter
- Single shunt for current sensing
- Sensing of DC-link voltage
- Measurement test points compatible to standard oscilloscope probes
- PCB size is 140 mm x 151 mm, two layers with 70 μm copper each
- RoHS compliant

1.4 Board parameters and technical data

Table 2 depicts the important specifications of the evaluation board EVAL-M1-IM828-A.

Table 2 EVAL-M1-IM828-A board specifications

Parameter	Symbol	Conditions / comments	Value	Unit
Input				
Input voltage	V_{AC}	Optimized design for 3-phase 380 V _{AC} or DC input. Lower AC input, less motor power output	320~480 V _{rms} AC /420~720 V DC	V
Input current	$I_{AC(max)}$	Input 3-phase AC 380 V _{rms} , 8 kW output, $T_a=25^{\circ}C$	20	A _{rms}

The board at a glance

Parameter	Symbol	Conditions / comments	Value	Unit
Output				
Power (3 phases)	$P_{in(max)}$	Input AC 380 V, FPWM=6 kHz, $T_a=25^{\circ}C$, $T_{case}=100^{\circ}C$	8000	W
Current per phase	$I_{mtr(max)}$	Input AC 380 V _{AC} , FPWM=6 kHz, $T_a=25^{\circ}C$, $T_{case}=100^{\circ}C$	15 A _{rms} /19 A _{rms} (low speed) ¹	A _{rms}
DC bus voltage				
Maximum DC bus voltage	$V_{DC(max)}$	DC bus capacitors are 450 V, 470 μ F X2 X2	780	V
Minimum DC bus voltage	$V_{DC(min)}$	Aux power supply's brown-in voltage	150	V
Current feedback				
Shunt resistance	R_{sh}	Two piece of 10 m Ω shunts in parallel	5	m Ω
Protections				
Motor current protection trigger level 1	I_{trip1}	Wizard setup for OC trigger level, related to shunt resistor RS1 & RS2 and current sensing bias	27 ²	A _{peak}
Motor current protection trigger level 2	I_{trip2}	Hardware comparator over-current protection, related to shunt resistor and LM393's setup	27	A _{peak}
Thermal protection level	$T_{protection}$	Users need to consider the temperature gap by NTC sensor; it is recommended to set temperature at 105 $^{\circ}C$ or less	100	$^{\circ}C$
Auxiliary power supply 1 – 15 V				
Output voltage	V_{out1}	Used for IPM, 12 V fan and relay (K1) drive	15 \pm 5%	V
Maximum output current	I_{out1}		300	mA
Auxiliary power supply 2 – 3.3 V				
Output voltage	V_{out2}	Used for IMC controller and protection circuits	3.3 \pm 5%	V
Maximum output current	I_{out2}		150	mA
PCB characteristics				
Dimension		Length \times width \times height	140 \times 151 \times 72	mm
Material		FR4, 1.6 mm thickness, 2 oz. PCB		
System environment				
Ambient temperature	T_a	Non-condensing, maximum RH of 75%	0 ~ 50	$^{\circ}C$

Note:

- As IPM and rectifier bridge are mounted on the same heat sink, IPM output capability is impacted by rectifier bridge's power loss.
- For iMOTION™ IC IMCxxx, there are three types of Gatekill input source options in MCEWizard setup: Gatekill-pin, Comparator and Both. If you select "comparator" mode, the external Gatekill signal will be not used, and the signal I_Shunt will be compared by the internal comparator with the "Device over-current trigger level setting" value set in MCEWizard.

2 System and functional description

2.1 Getting started with EVAL-M1-IM828-A

In order to run the motor system, a combination of the iMOTION™ MADK power board (EVAL-M1-IM828-A) and the matching MADK control board (EVAL-M1-101T or other control board) are required. This chapter provides more details on setting up the system and getting started with the iMOTION™ MADK development platform.

The EVAL-M1-IM828-A reference designs are tested with EVAL-M1-101T controller boards, which shipped with embedded firmware and default parameters.

Figure 3 shows the basic system connection using EVAL-M1-IM828-A to run an 8 kW GK6081-6AC31 motor with MCEDesigner.

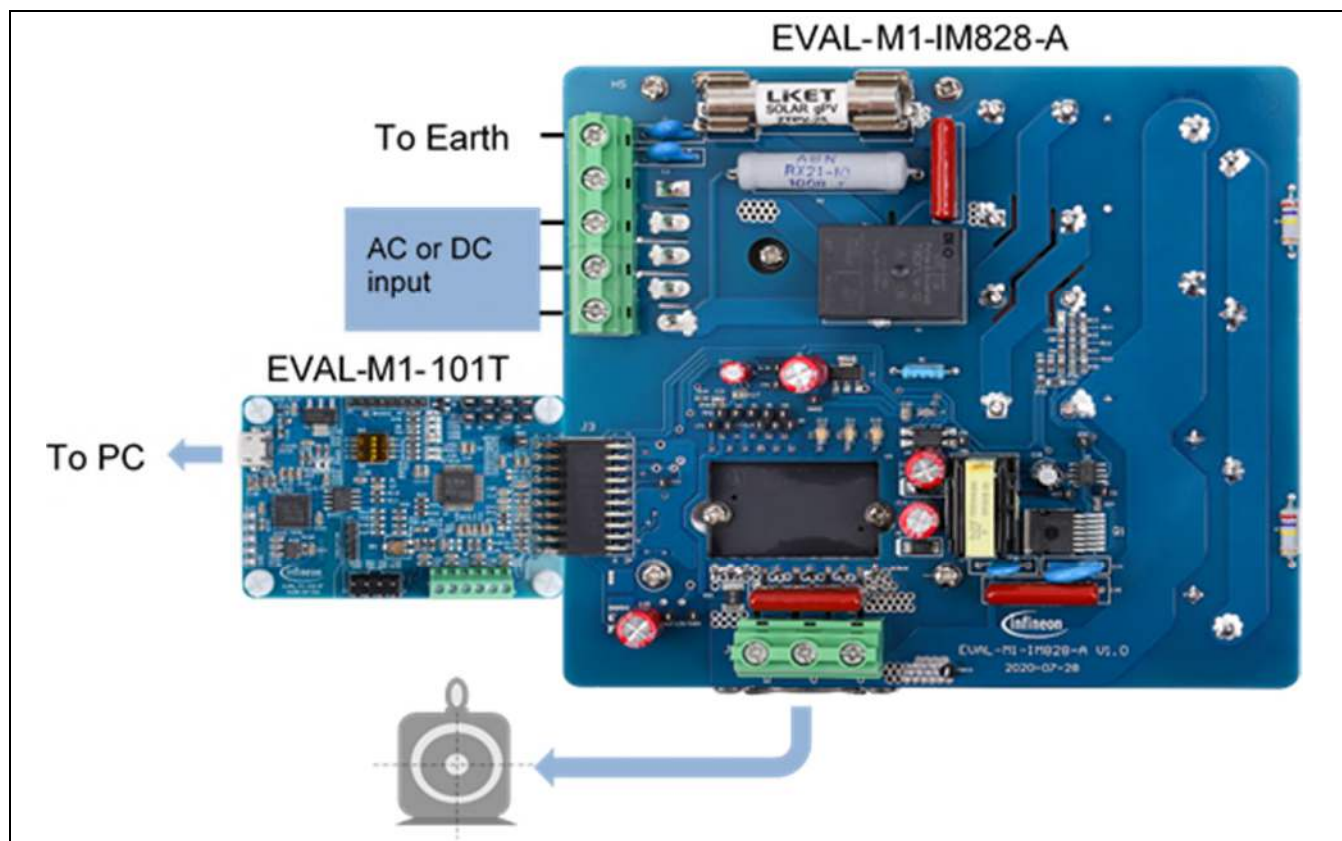

Figure 3 System connection example

2.1.1 iMOTION™ control board

1. If you want to use the Infineon control board, please go to the Infineon website, www.infineon.com/MADK, and order EVAL-M1-101T.
2. Then get the latest “IMC101T-T038 MCE Software Package” available on the website, www.infineon.com/imotion-software
3. After you have obtained the control board and software, you are ready to connect your PC to EVAL-M1-101T via USB cable, and to program and tune the control board.
4. Connect EVAL-M1-101T’s M1 20-pin interface connector (J2) to power board (for example EVAL-M1-IM828-A, see Figure 5).
5. Use MCEWizard to enter the target motor’s system and operating parameters, as well as the evaluation board’s hardware parameters, which will then be used to calculate the controller’s set digital parameters

System and functional description

representing the complete motor drive system. First click the “Calculate” button on the “Verify & Save Page” and then save the drive parameter set into your project directory by clicking “Export to Designer file (.txt)”. The saved drive system parameter file will be later used by the MCEDesigner. Refer to Chapter 2.1.4 or MCEWizard user guide for more details.

6. Connect motor phase outputs to the motor.
7. Connect 3-phase AC 380 V or DC power to power input connector and power-on system.
8. Start MCEDesigner tool and open MCEDesigner default configuration file (.irc) for IMC101T-T038 controller (IMC101T_Vxxx.irc) by clicking “File” > “Open”. IMC101T_Vxxx.irc file is included in the “IMC101T-T038 MCE Software Package” downloaded in step 2.
9. MCEDesigner should automatically connect to the EVAL-M1-101T control board using default COM port (indicated by green circle next to “COMx Up” status in the bottom frame of the MCEDesigner GUI). If it cannot establish the connection, change the COM port as follows: (“System” window active) > Preferences > Connection > Connect using (select one of the other available COM ports from the drop-down menu).
10. Use the following steps to program the system parameters into the internal SRAM of iMOTION™ IC: Click “Tools” > “Programmer” and select “Program Parameters.” Browse and select the System Drive Parameters .txt file created in step 5. See Chapter 2.1.4 for more details.
11. Start the motor by clicking the green traffic light button in the control bar.
12. Stop the motor by clicking the red traffic light button in the control bar.

2.1.2 iMOTION™ development tools and software

The iMOTION™ development tool installers for MCEDesigner and MCEWizard are available for download via Infineon iMOTION™ website (<http://www.infineon.com/imotion-software>). All supported tools and software variants are listed there. Please visit this page periodically to check for tool/software updates.

The isolated on-board debugger provides the USB-to-UART bridge between the PC and the target iMOTION™ device with 1 kV DC galvanic isolation between the motor drive system (hot side) and the PC/debugger (cold) side. The on-board debugger uses the SEGGER J-Link driver for UART communication with IMC101T-T038. The J-Link driver will be installed during the MCEDesigner installation. In case the driver is not installed properly, please go to the SEGGER J-Link website to download and install the latest J-Link “Software and Documentation pack for Windows.”

2.1.3 MCEWizard setup overview

Double-click the shortcut to open the MCEWizard and configure the parameters for evaluation boards or motor. Figure 4 shows the “Welcome Page” for MCEWizard, where the MADK control board or power board can be selected from the pull-down list. Infineon continues to release new MADK controller and power boards. Therefore, it is possible that some of the latest power boards have not been pre-configured in the MCEWizard tool and cannot be selected from the pull-down menu. In that case, the user should select another power board (as similar as possible) and follow the MCEWizard setup steps by entering the parameter values that are specific to the chosen board. Make sure both “I have modified the circuit board” and “Enable advanced question” checkmarks are selected. Please refer to the Application Note of the corresponding power board for additional information.

After selecting the MADK control and the power board, start the MCEWizard system setup procedure by clicking the “Next” button in the right bottom corner as shown in Figure 4.

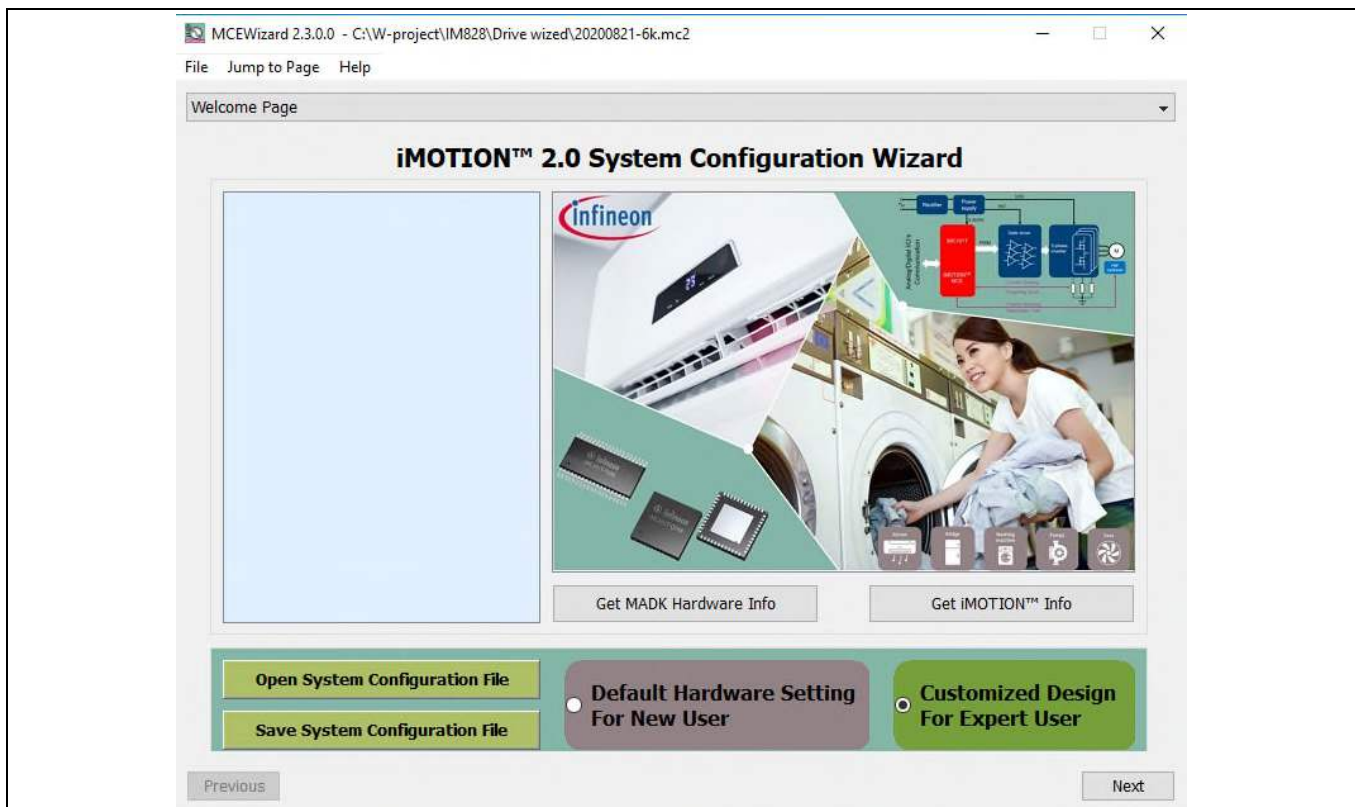

Figure 4 Welcome page of MCEWizard

The iMOTION™ MADK system enables users to easily test different combinations of control and power boards with their motors. Users should be familiar with the system level parameters that are related to the motor used. There is a very limited number of parameters which are specific to the control board or power board hardware. Table 3 provides the MCEWizard setup overview for hardware related parameters specific to EVAL-M1-IM828-A power board. Similar tables will be available in each control board’s Application Note. A combination of this table and the corresponding table of the control board provides sufficient information to set up the MADK-based motor drive system rapidly.

Table 3 MCEWizard setup overview table

Parameter	Value
Control board selecting	EVAL-M1-101T for example
Power board selecting	EVAL-M1-IM828-A
Motor 1 shunt configuration	Single shunt
Controller supply voltage	+3.3 V
Max DC bus voltage	780 V
DC bus sensing high resistor	5000 kΩ
DC bus sensing low resistor	Refer to the control board’s user guide
NTC temperature shutdown value	Refer to the control board’s user guide
GateSense low-side devices	High is true
GateSense high-side devices	High is true
Motor 1 current input	Calculated in the corresponding section in control board’s user guide. For current feedback setup, please see “3.6 Current feedback to control board”.

After all the MCEWizard questions are answered, the “Verify & Save Page” will be shown as in Figure 5.

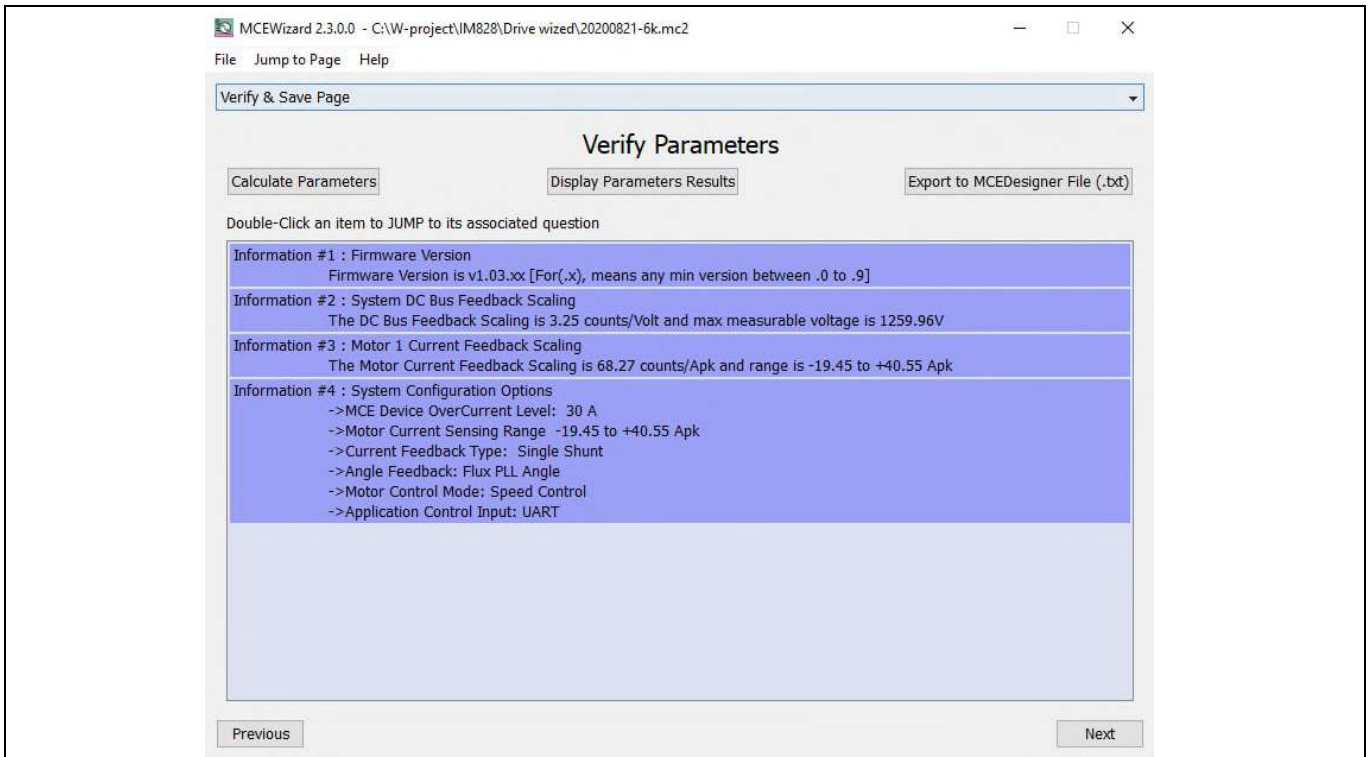

Figure 5 Verify and save page of the MCEWizard

Click “Calculate Parameters” button and “Export to Designer File (.txt)” button to save the parameter file which will be used by the MCEDesigner in the next steps.

2.1.4 MCEDesigner setup overview

After installing MCEDesigner, there is a shortcut for the MCEDesigner on Windows desktop. Double-click the shortcut to open MCEDesigner and then open “IMC101T_xx.irc” file as shown in Figure 6.

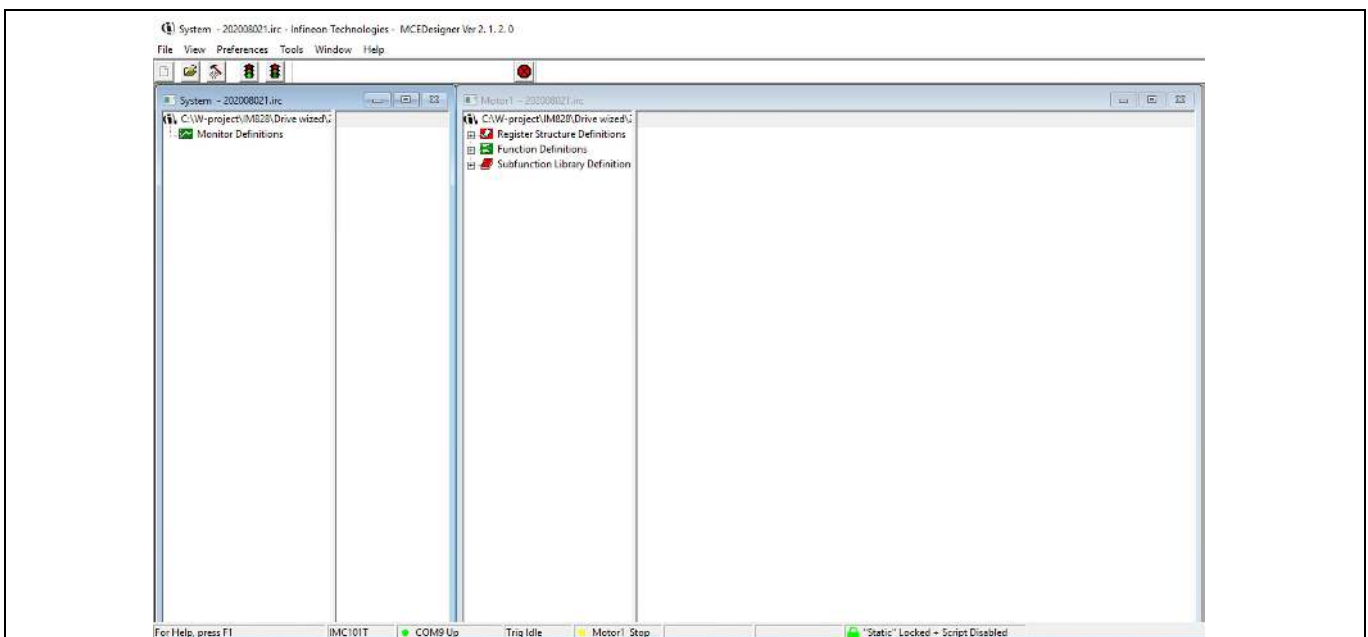

Figure 6 MCEDesigner main display for EVAL-M1-101T

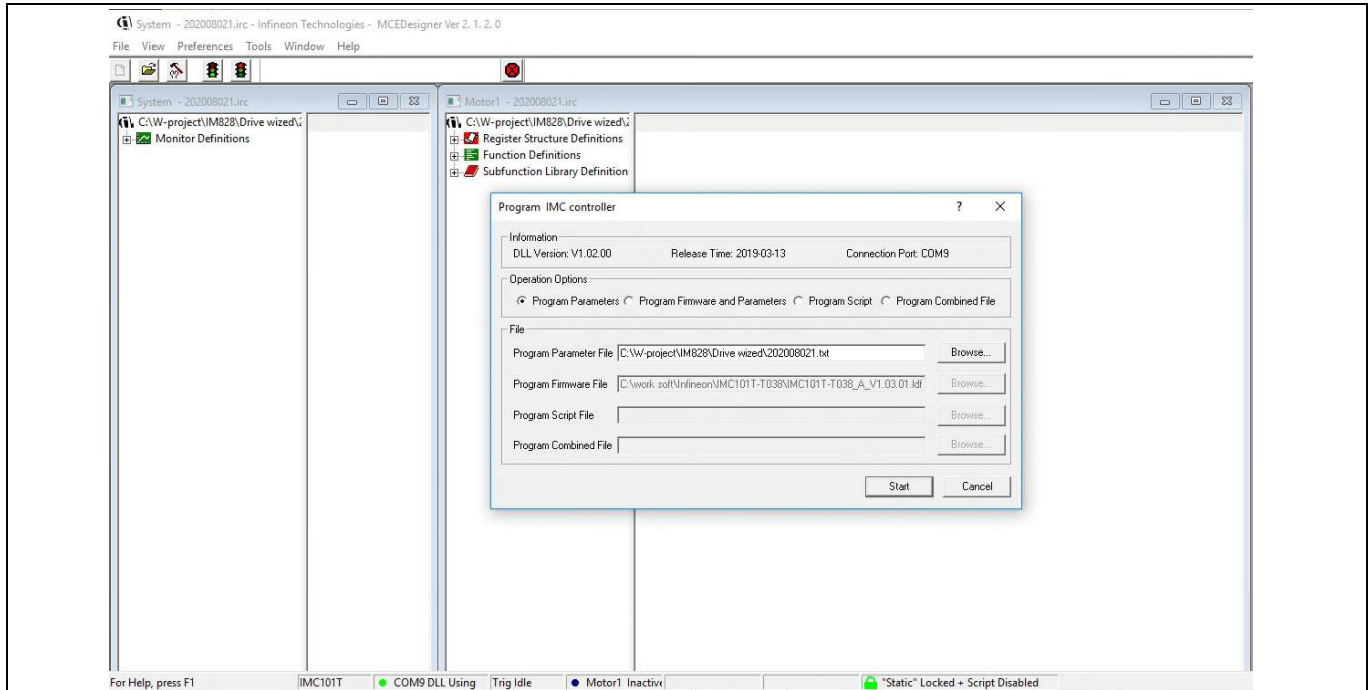

Figure 7 “Program IMC controller” pop-up window

After the drive system parameter file has been programmed into the IMC101 controller, and the motor drive system is powered, the MCEDesigner can be used to start/stop the motor, display motor current traces, change the motor speed, modify drive parameters and many other functions. Please refer to the MCEDesigner documentation for more details.

Note: The on-board debugger section of the EVAL-M1-101T has galvanic isolation from the controller section and the attached power board. In order to program the parameters or firmware to the IMC101T-T038 controller, the 3.3 V DC voltage needs to be supplied to the controller section of the EVAL-M1-101T. This voltage can either be supplied by the power board (MADK power boards are designed to supply the 3.3 V to the control board via M1 or M3 connector) or by feeding the 3.3 V voltage to the control board via some of the available 3.3 V access/test points if the power board is not attached to the EVAL-M1-101T control board.

To program new firmware and the drive system parameters into IMC101T-T038, please click the “Tools” menu and select “Programmer” in the pull-down list. The pop-up window “Program IMC controller” will show up as in Figure 8. Click on the “Program Firmware and Parameter” radio button, and select the “Drive System Parameter” file created using MCEWizard by clicking on the “Browse” button on the row of “Program Parameter File”, and then select the firmware file by clicking on the “Browse” button in the row of “Program Firmware File.” Finally, click on the “Start” button to program the parameter file into the IMC101T-T038 IC.

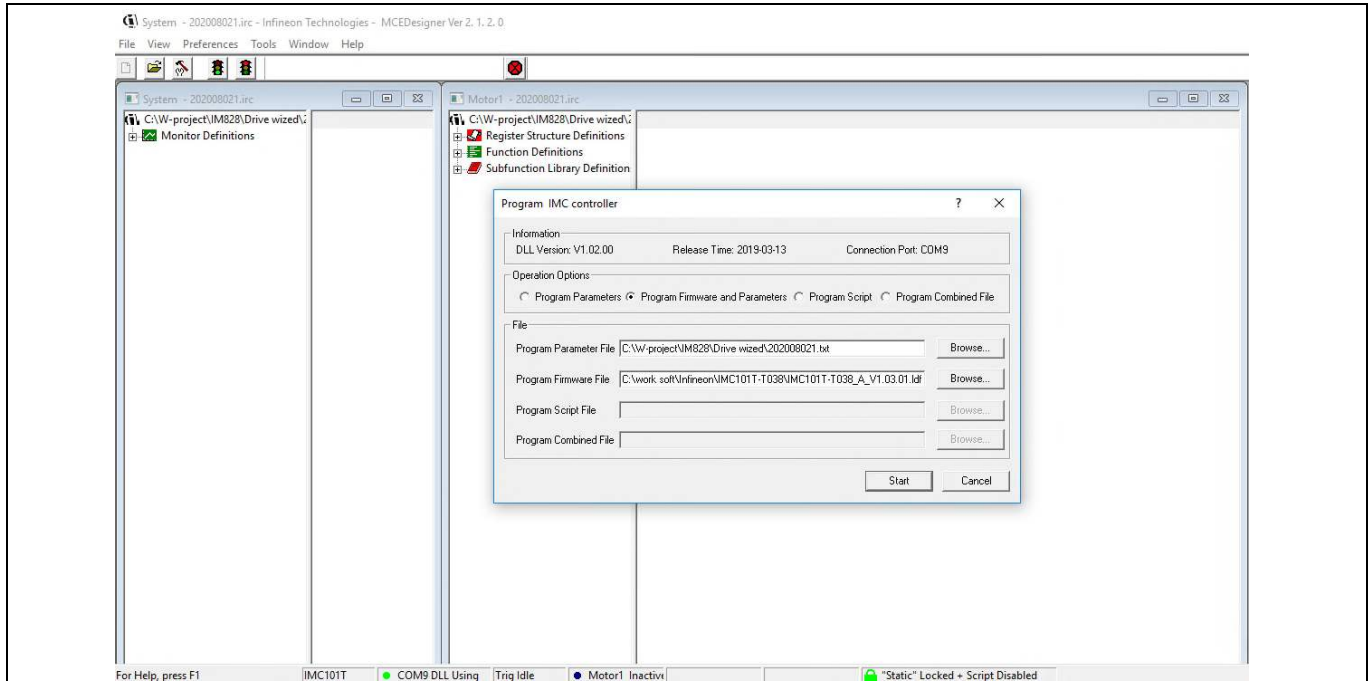

Figure 8 Program firmware and parameter in “Program IMC controller” pop-up window

2.2 The current waveform from MCEDesigner

MCEDesigner has a parameter trace function for debugging and checking the PCB layout/parameter settings in the “.irc” window.

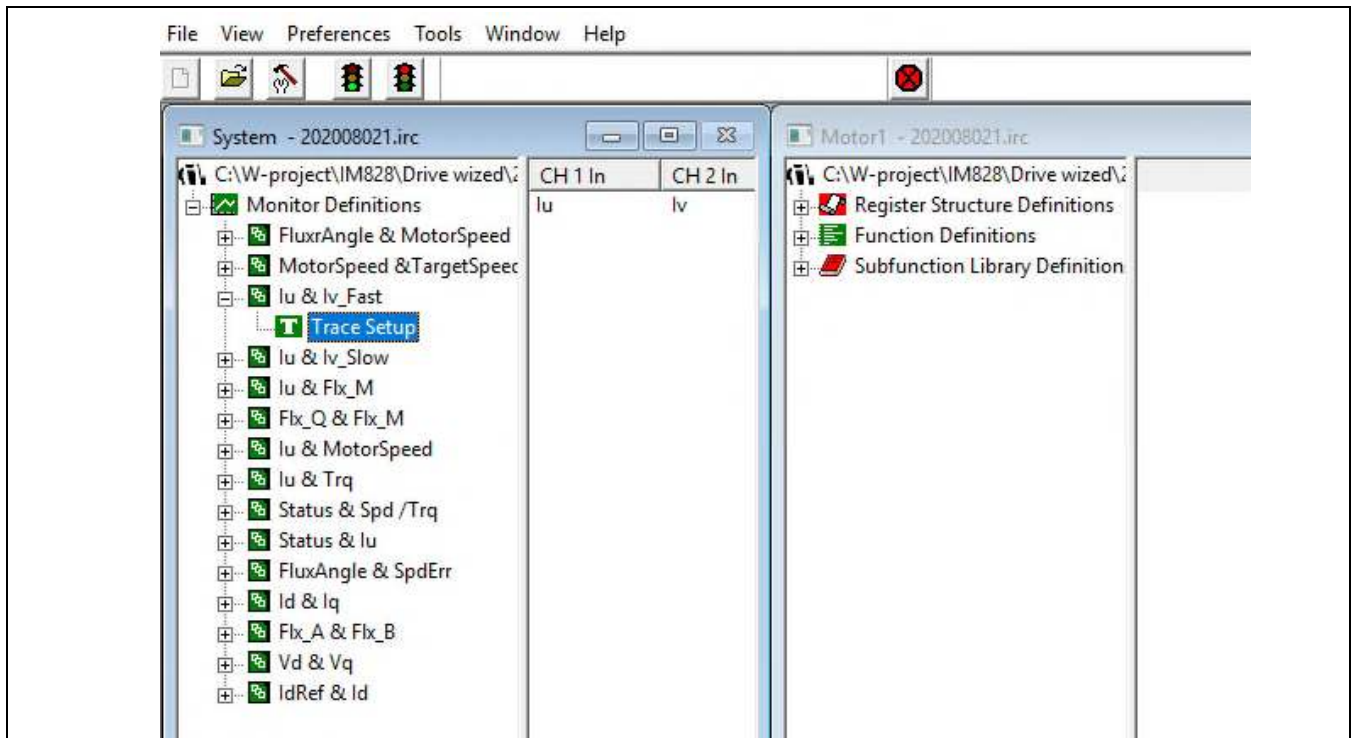

Figure 9 Trace function in MCEDesigner window

The trace function shows what the MCE “saw.” The figures below are the motor current waveform at stop and running status.

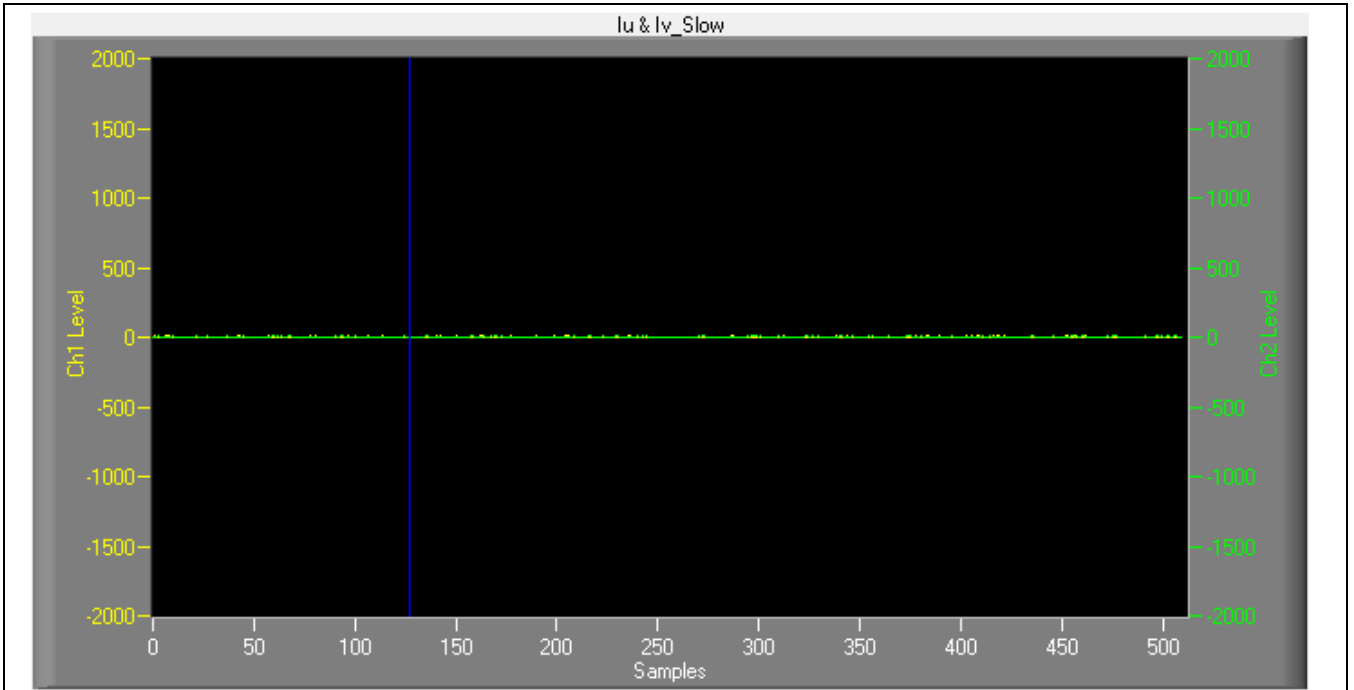

Figure 10 I_u and I_v static noise waveform from MCEDesigner

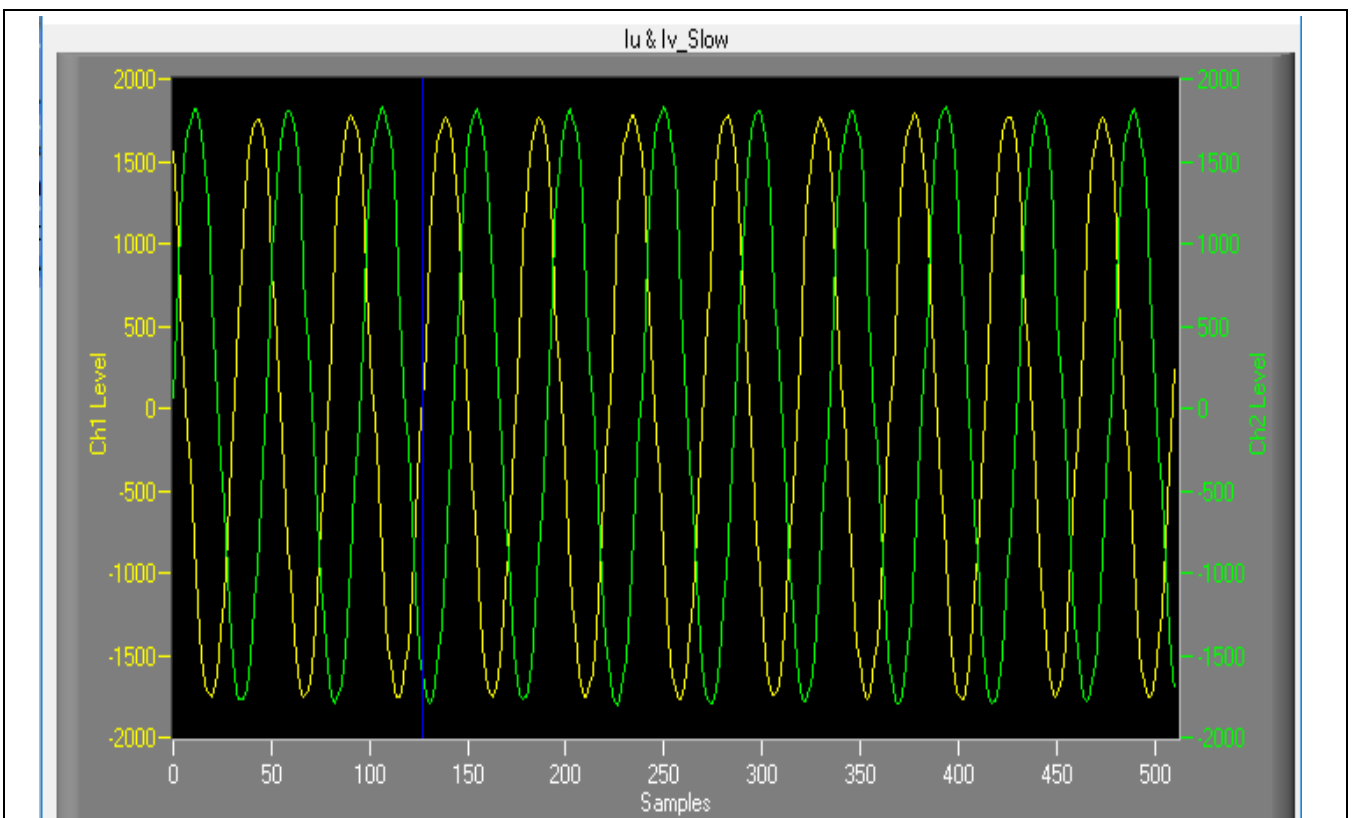

Figure 11 I_u and I_v waveform @380 V AC input, 18.5 A output current with 6 kHz carrier frequency

This is typical current waveform of a sinusoidal brushless motor driven by the EVAL-M1-IM828-A and EVAL-M1-101T with iMOTION™ software.

2.3 Description of the functional blocks

The motor inverter of EVAL-M1-IM828-A reference design is implemented by the IM828-XCC module, and the auxiliary power supply is based on quasi-resonant controller: ICE5QSAG and CoolSiC™ MOSFET IMBF170R1K0M1.

2.3.1 Overview of IM828-XCC

Figure 12 provides the overview of the IM828-XCC internal electrical schematics. For further information regarding these CIPOS™ SiC IPMs such as static and dynamic electrical behavior, as well as thermal and mechanical characteristics, please refer to the datasheet of the IM828-XCC.

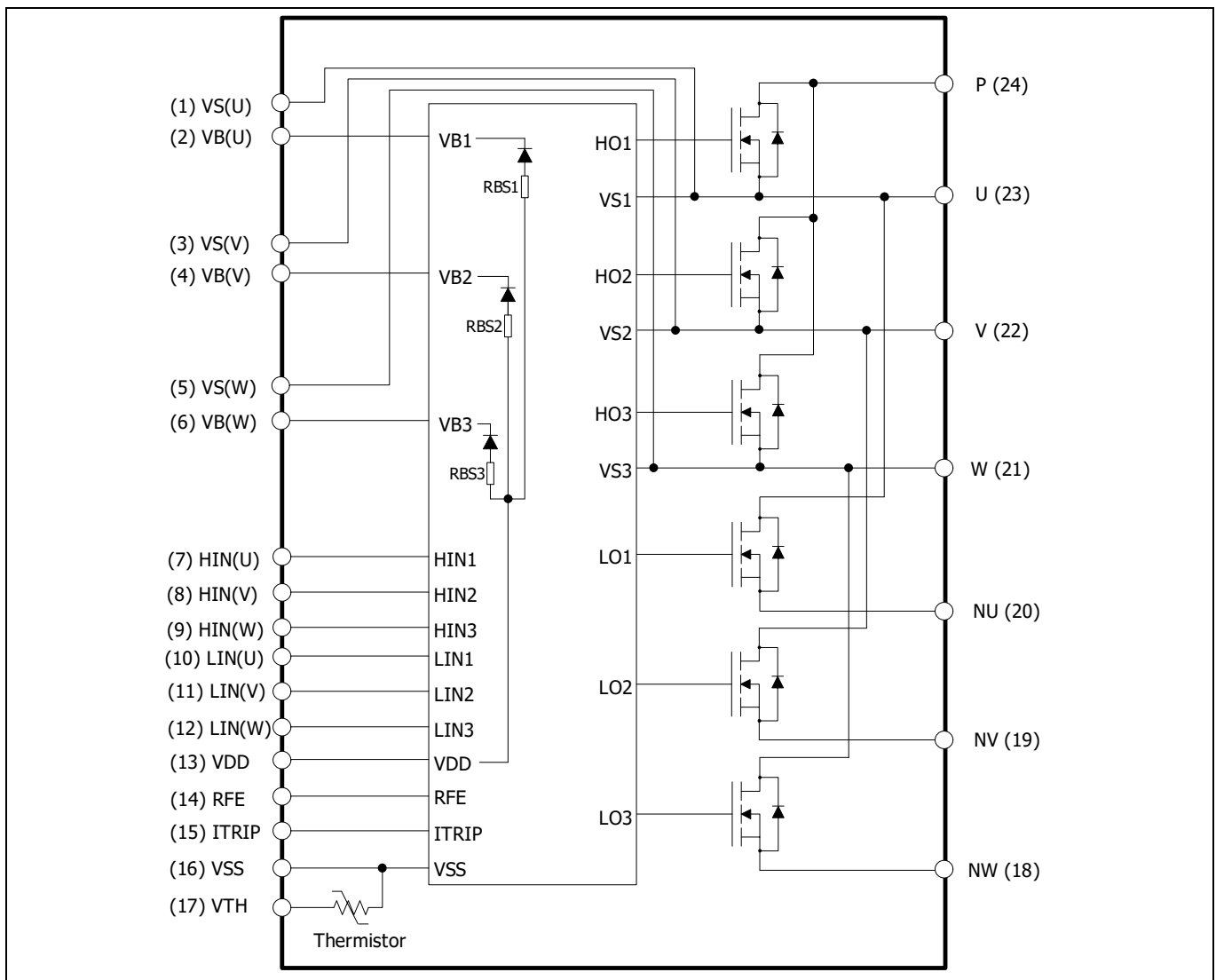

Figure 12 IM828-XCC internal electrical schematic

The main features of CIPOS™ Maxi IPM IM828-XCC include:

- 1200 V CoolSiC™ MOSFETs
- Maximum blocking voltage $V_{CES} = 1200\text{ V}$
- Maximum output current at 25°C case temperature $I_D = 35\text{ A}$
- Rugged 1200 V SOI gate driver technology with stability against transient and negative voltage
- Allowable negative V_S potential up to -11 V for signal transmission at $V_{BS} = 15\text{ V}$

EVAL-M1-IM828-A user guide

Modular application design kit (MADK) of IM828-XCC

System and functional description

- Integrated bootstrap functionality
- Over-current shutdown
- Built-in NTC thermistor for temperature monitoring
- Under-voltage lockout at all channels
- Low side emitter pins accessible
- For all phase current monitoring (open emitter)
- Cross-conduction prevention
- All of 6 switches turn off during protection
- Programmable fault clear timing and enable input
- Lead-free terminal plating; RoHS compliant

Table 4 Absolute maximum ratings of IM828-XCC

Symbol	Description	Min	Max	Unit	
V_{DS}	MOSFET drain-to-source voltage	--	1200	V	
I_D	DC drain current	$T_c = 25^\circ\text{C}, T_J < 150^\circ\text{C}$	--	35	A
		$T_c = 80^\circ\text{C}, T_J < 150^\circ\text{C}$	--	20	A
P_d	Maximum power dissipation per MOSFET	--	86	W	
T_J (MOSFET & IC)	Operating junction temperature	-40	150	$^\circ\text{C}$	
T_s	Storage temperature range	-40	125	$^\circ\text{C}$	
V_{BS}	High side floating supply voltage	-1	20	V	
V_s	High side floating supply offset voltage	--	1200	V	
V_{DD}	Module control supply voltage	-1	20	V	
V_{IN}	Input voltage (LIN, HIN, REF)	-1	$V_{DD} + 0.3$	V	
V_{RRM}	Repetitive peak reverse voltage of bootstrap diode	--	1200	V	

2.3.2 Overview of IMBF170R1K0M1

The IMBF170R1K0M1 is Infineon's CoolSiC™ 1700V SiC Trench MOSFET, offers high performance, high efficiency and easy to use with DC 120~1000 V full voltage range safe industrial auxiliary power supply for fly-back topology.

This is the MOSFET package and definition:

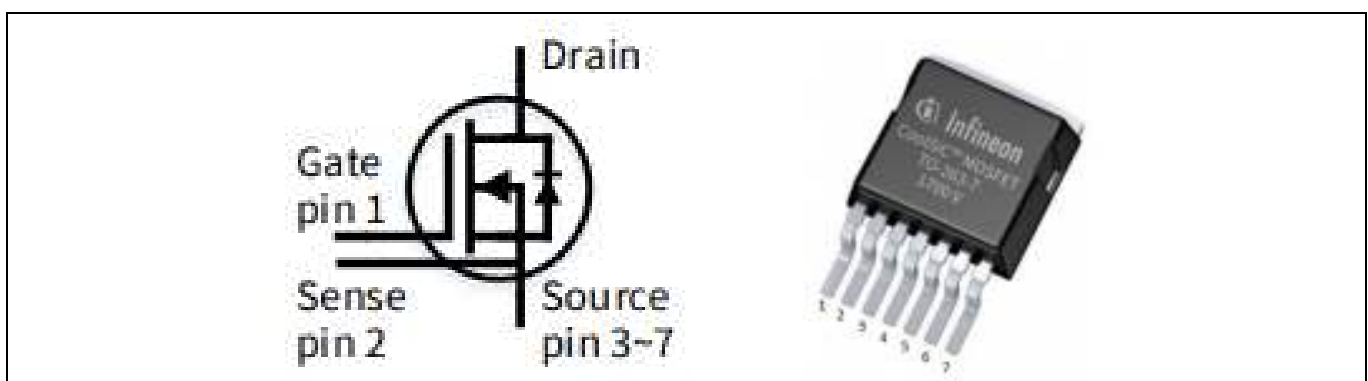

Figure 13 IMBF170R1K0M1 package: PG-T0263-7 and pin definition

System and functional description

The main features of CoolSiC™ MOSFET IMBF170R1K0M1 include:

- 1700 V CoolSiC™ MOSFET
- Revolutionary semiconductor material - Silicon Carbide
- Optimized for fly-back topologies
- 12 V/0 V gate-source voltage compatible with most fly-back controllers
- Very low switching losses
- Benchmark gate threshold voltage, $V_{GS(th)} = 4.5V$
- Fully controllable dV/dt for EMI optimization

Table 5 Absolute maximum ratings of IMBF170R1K0M1

Symbol	Description	Value	Unit	
V_{DS}	MOSFET drain-to-source voltage	1700	V	
I_D	DC drain current	$T_C = 25^\circ C$	5.2	A
		$T_C = 100^\circ C$	3.7	A
P_{tot}	Power dissipation, limited by T_{vjmax}	$T_C = 25^\circ C$	68	W
		$T_C = 100^\circ C$	34	W
$I_{D,pulse}$	Pulsed drain current, t_p limited by T_{vjmax} , $V_{GS} = 12 V$	13.3	A	
T_{vj}	Virtual junction temperature	-55 ~ 175	$^\circ C$	

System design

3 System design

The EVAL-M1-IM828-A board is an optimized design for 3-phase AC 380V major home and industry appliances. To meet individual customer’s requirements and to make the EVAL-M1-IM828-A reference design a basis for development or modification, all board design data such as schematics, Gerber and Altium design data can be found on the Infineon homepage and log in your account to download them.

3.1 Inverter section using CIPOS™ Maxi

The inverter section is implemented using the CIPOS™ Maxi as sketched in Figure 14. This is 3-phase inverter bridge section with Infineon CoolSiC™ SiC MOSFET and driver inside. RS1/RS2 are single shunt for current sensing. The three capacitors C10, C11 and C12 are used as bootstrap capacitors to provide the necessary floating supply voltages VBU, VBV and VBW respectively. C24 is a DC bus snubber for IPM.

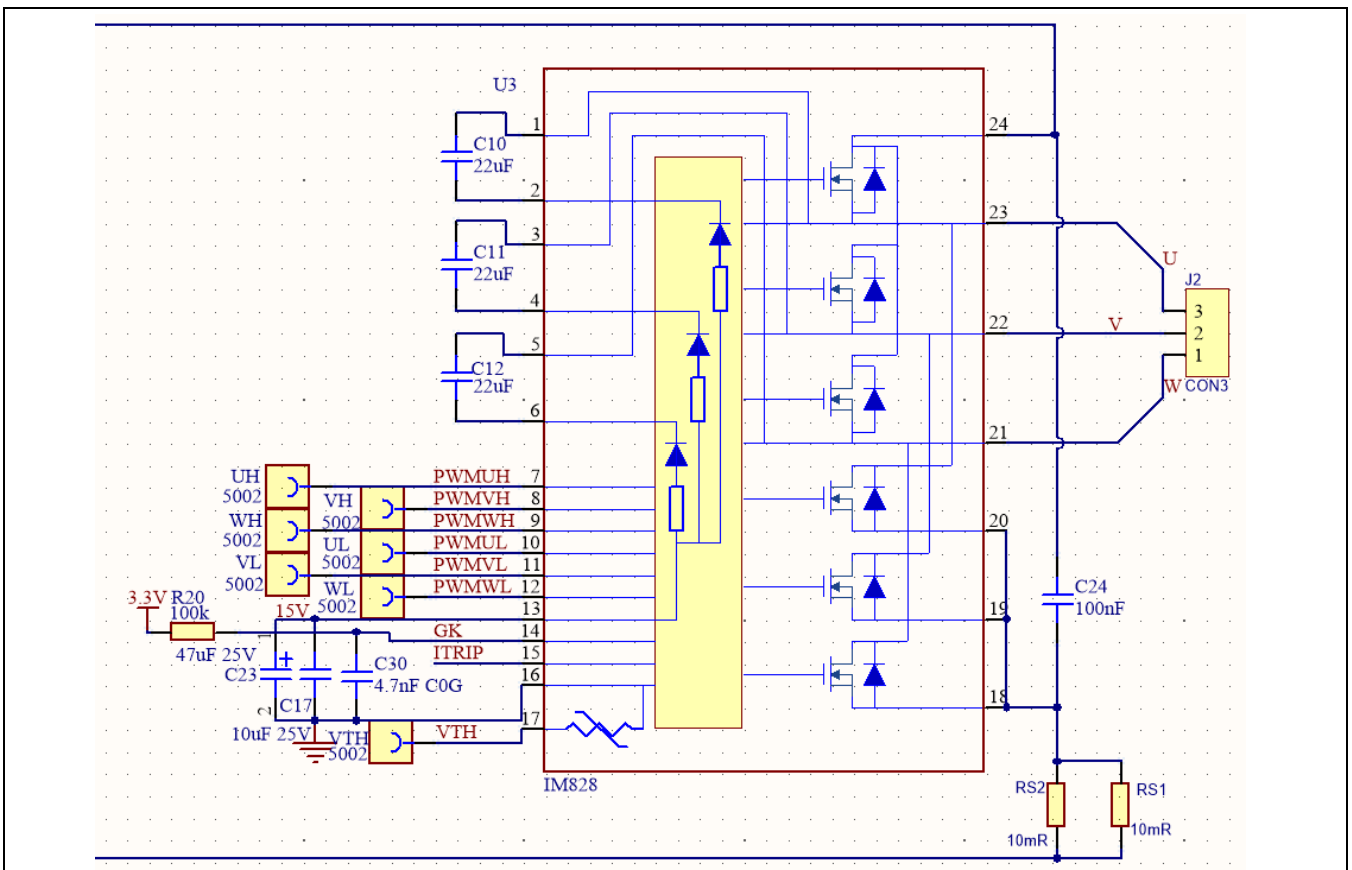

Figure 14 The diagram of the inverter section

3.2 DC/DC

Figure 15 depicts the schematic of the power supply available on the EVAL-M1-IM828-A board. The circuit is ZVS fly-back topology; the input voltage range is 150~780 V DC bus, and the discharge DC bus is go to lower than 60 V in 180 seconds (by K1 and fan) when power is turned off. It includes the ICE5QSAG and CoolSiC™ 1700 V SiC trench MOSFET used to generate 15 V and 6 V directly from the DC bus. 15 V is connected to the gate drivers inside the CIPOS™ Maxi IPM, which generates 12 V for K1 and fan. 3.3 V power supply is from DC6 V by linear regulator IFX25001ME V33. The 3.3 V power supply is used in the over-current comparator circuit. Both 15 V and 3.3 V are also present on the 20-pin interface connector J3.

System design

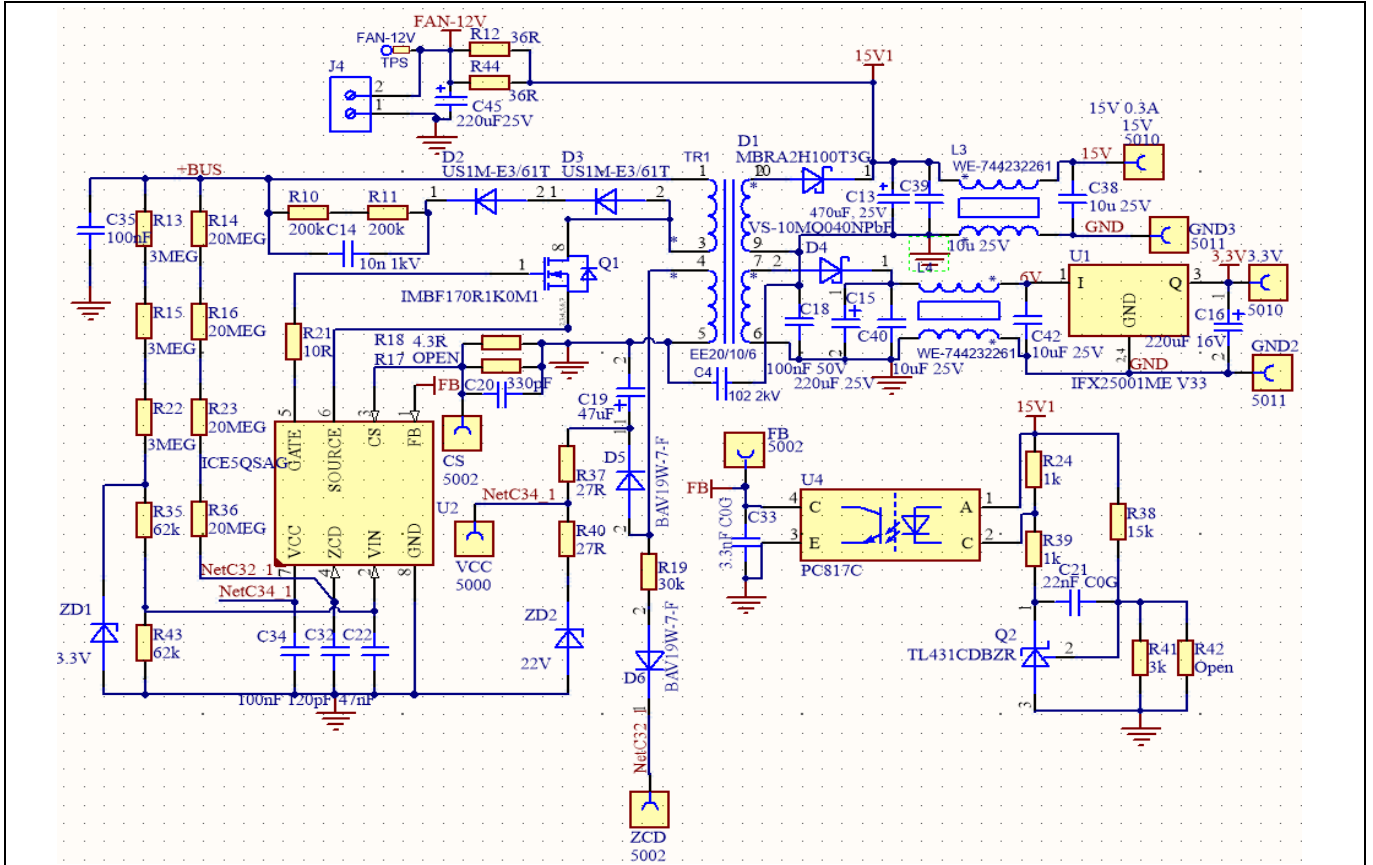

Figure 15 DC/DC power supply

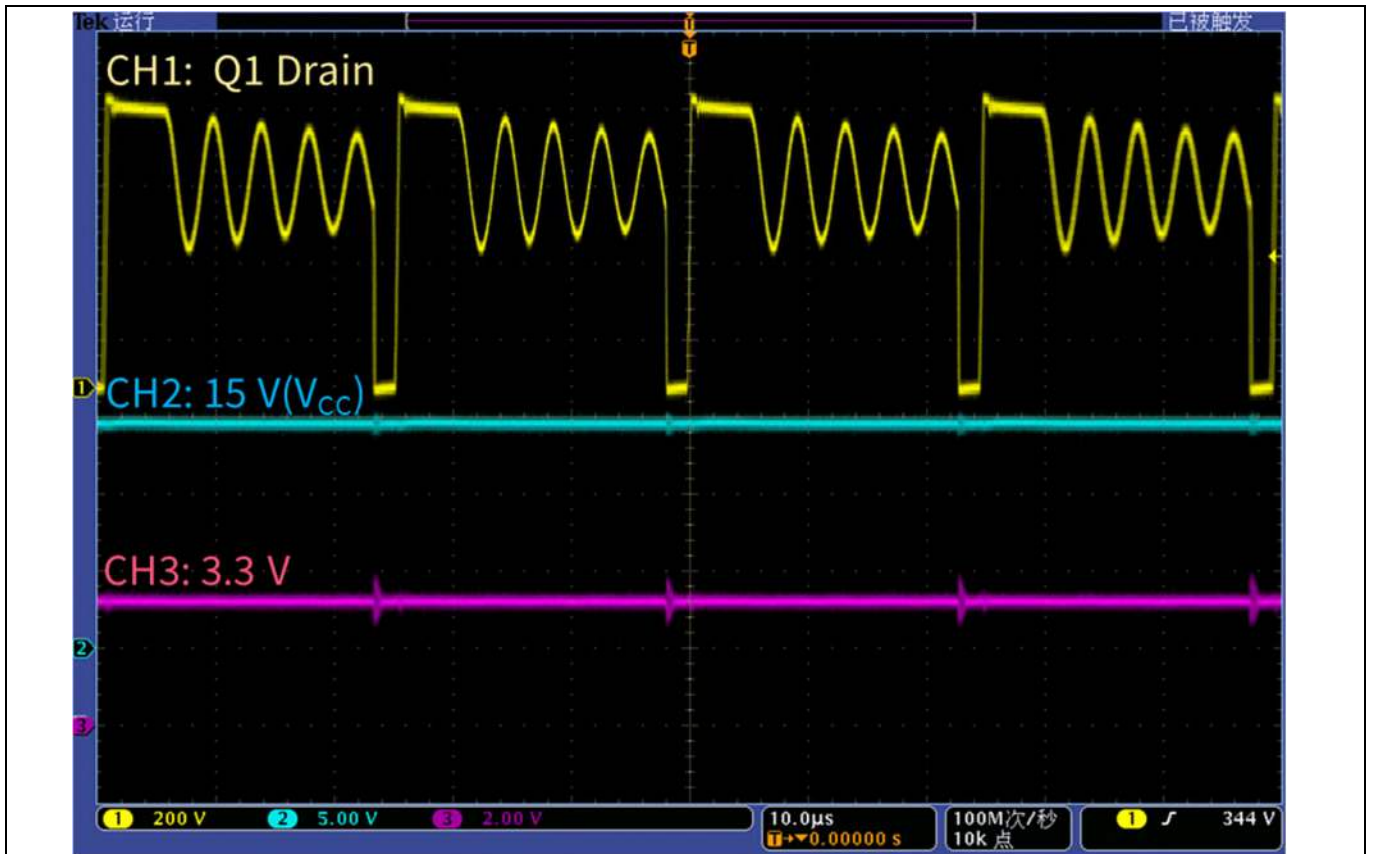

Figure 16 Q1 ZVS switching and 15 V/3.3 V output at 430 VAC input

EVAL-M1-IM828-A user guide

Modular application design kit (MADK) of IM828-XCC

System design

3.3 AC/DC input and soft start

Figure 17 depicts the schematic of the AC/DC input section. It includes the connector J1, the rectifier (DB), soft start (R2, K1), a passive EMI filter (C1, C2, L1, L2), a fuse F1 for over-current protection, and DC bus capacitors (C6, C7, C8, C9).

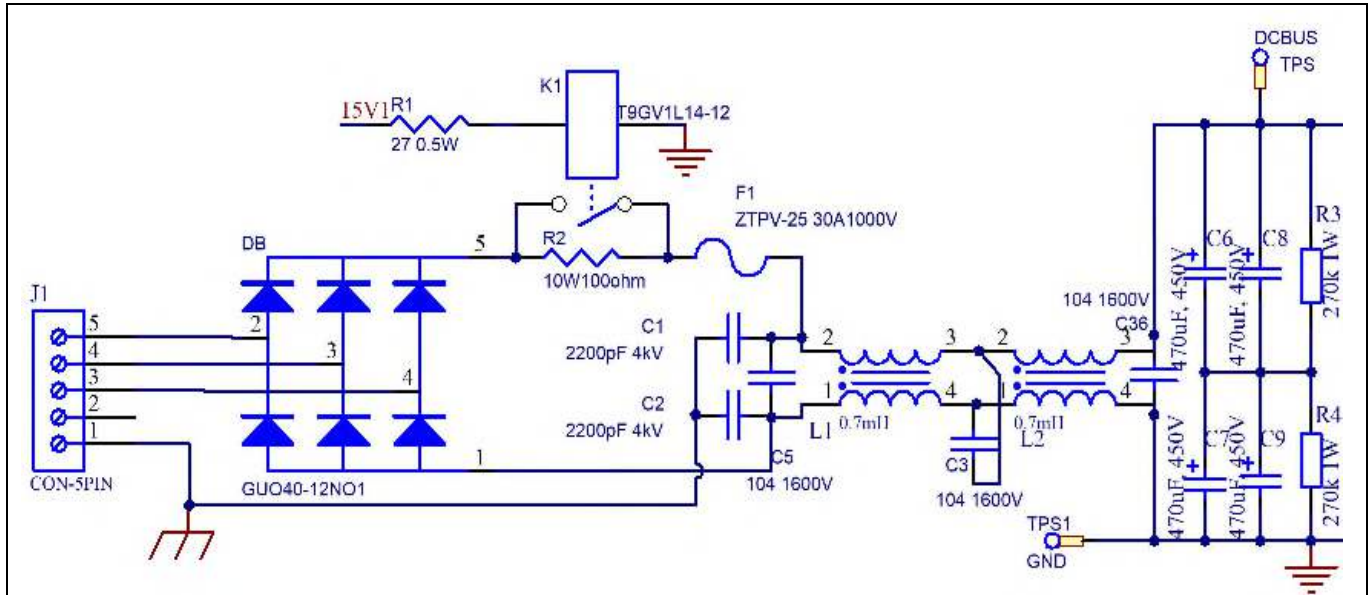

Figure 17 The schematic of AC/DC section and soft start circuit

3.4 DC-link voltage measurement

Pin 14 of connector J3 provides access to the DC-link voltage.

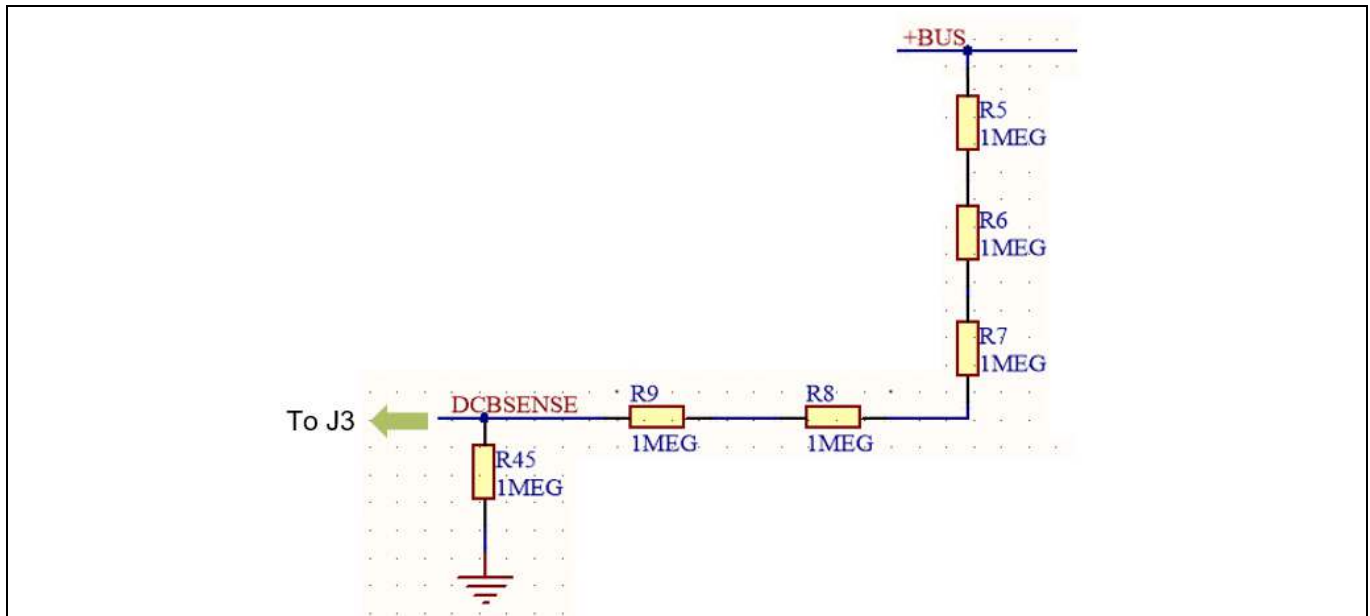

Figure 18 DC bus sensing

R45 is the safety resistor on the connection port when the connector is open. The DC-bus sensing low-side resistance is $R45 // R1$ ($R1$ is on EVAL-M1-101T). It is $1\text{ M}\Omega // 13.3\text{ k}\Omega = 13.13\text{ k}\Omega$

System design

3.5 Current sensing and amplifier

EVAL-M1-IM828-A has single shunt sensing by RS1//RS2. The final value of shunt resistance is 5 mΩ. The current output IU+ goes to J3.

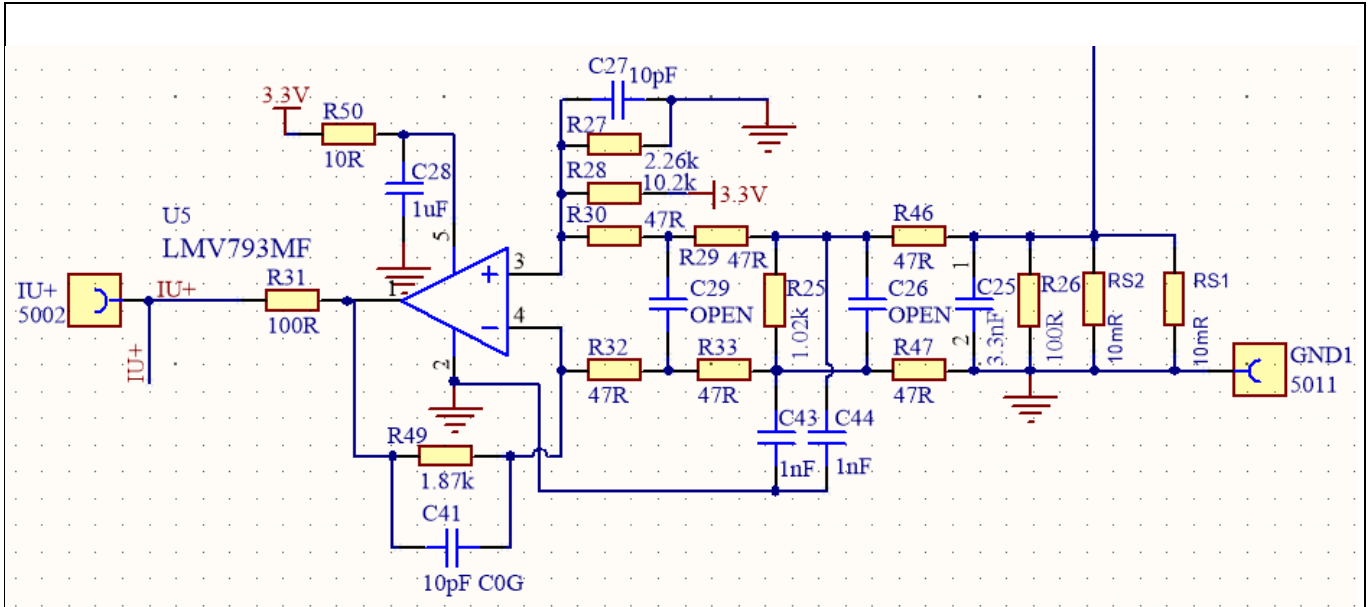

Figure 19 Current sensing and signal amplification

R29 / R33 / R46 / R47 / C25 / C26 / C29 are for low-pass filter (LPF) for EMC noise from shunt resistor. R30 / R32 / R49 / C41 and U5 consist of a low-noise proportional amplifier. The gain of the amplifier is:

$$\text{Gain} = \frac{R49}{R32 + R33 + R47} \approx 13.26$$

The current scaling is:

$$V_{\text{shunt}} = \frac{RS1 \times RS2}{RS1 + RS2} \times \text{Gain} = 66.3 \text{ mV/A}$$

Static status:

$$V_o = \frac{R27 \times 3.3V}{R27 + R28} = 0.6 \text{ V}$$

The response time:

$$T_o \approx \frac{1}{\frac{GBW}{\text{Gain} - 1}} = 0.15 \mu\text{s}$$

R31 is U5 output transmission matching resistor. GBW is the gain bandwidth of U5.

3.6 Current feedback to the control board

The circuit below shows the feedback current signal to the control board. The offset circuit consists of R6 and 3.3 V on the EVAL-M1-101T.

System design

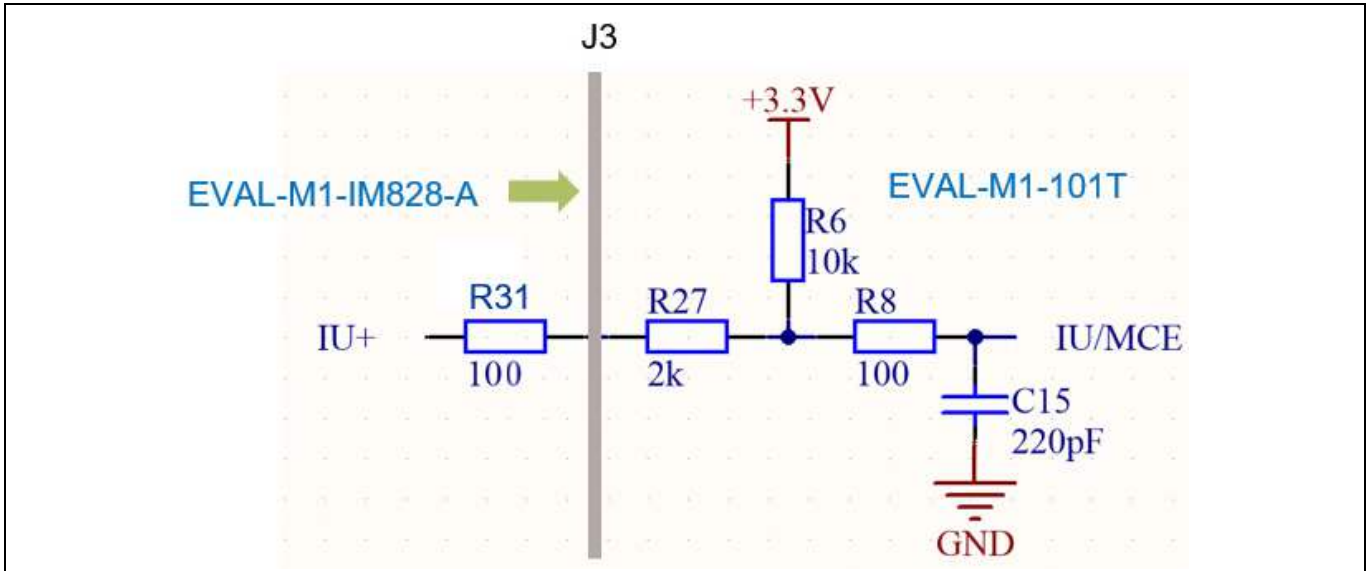

Figure 20 Current signal transmission between EVAL-M1-IM828-A and EVAL-M1-101T

The attenuation of the current signal from IU+ to J3 (Pin 10 IU+):

$$\alpha = \frac{R6}{R6 + R21 + R27} = 0.826$$

Total gain to IU input:

$$\Sigma G = \alpha \times \text{Gain} = 10.96$$

Total current scaling to IU input:

$$V_{\text{shunt}2} = R16 \times \Sigma G = 54.8 \text{ mV/A}$$

Motor 1 Current Feedback and Sample Timing

Question 83 - Motor 1 Current Input Scaling Expand Picture

This parameter is the gain of the external current single/leg shunt measurement circuit.

This value is the product of the shunt resistance in milliohms and the ac gain of the offset and gain circuit:
 $G_{\text{ext}} \times R_s$.

In the circuit example, the gain calculated from analysis with $R_s \sim 0$, is given by:
 $G_{\text{ext}} = R2 / (R1 + R2)$.

The input filter capacitor, C1, should be selected so that the offset and gain circuit time constant is less than 400ns to minimize the impact on current sampling.

High current applications may require an active offset and gain circuit to support low resistance shunts or to improve the measurement signal to noise ratio.

Answer: mV/A

Figure 21 Current input scaling setup with MCEWizard

EVAL-M1-IM828-A user guide

Modular application design kit (MADK) of IM828-XCC

System design

The current offset to IU input:

$$V_{\text{offset}} = \frac{(3.3 \text{ V} - 0.6 \text{ V}) \times (R21 + R27)}{R6 + R21 + R27} + 0.6 \text{ V} = 1.07 \text{ V}$$

Since control board ADC range is 3.3 V, we have to select the internal gain of control board to “1”.

Motor 1 Current Feedback and Sample Timing

Question 84 - Internal Current Feedback Amplifier Gain Expand Picture

This parameter is the gain set for the programmable gain amplifier between the current sense pin and the ADC.

This parameter is the gain set for the programmable gain amplifier between the current sense pin and the ADC.

The available gain values are 1, 3, 6 and 12. The net gain provided by the internal and external amplifiers determines the current feedback range: $I_{\text{range}} = (VDD/2)/(G_{\text{int}} \times G_{\text{ext}} \times R_s)$

The product of the gain and the voltage offset (V_{off}) should be 50% of VDD to ensure current sensing is centered around zero.

An amplifier gain greater than 1 supports the use of low resistance shunts to minimize the shunt power loss and size. It also allows setting the overcurrent comparator level outside the current measurement range and maximize the use of the ADC measurement range.

$V_{AD} = G_{int} (V_{CM} + G_{ext} \times R_s \times I_s)$

$V_{in} = V_{off} + G_{ext} \times R_s \times I_s$

$V_s = I_s \times R_s$

Answer:

Figure 22 Current feedback amplifier gain setup with MCEWizard.

System design

3.7 ITRIP and GK setup

3.7.1 ITRIP setup

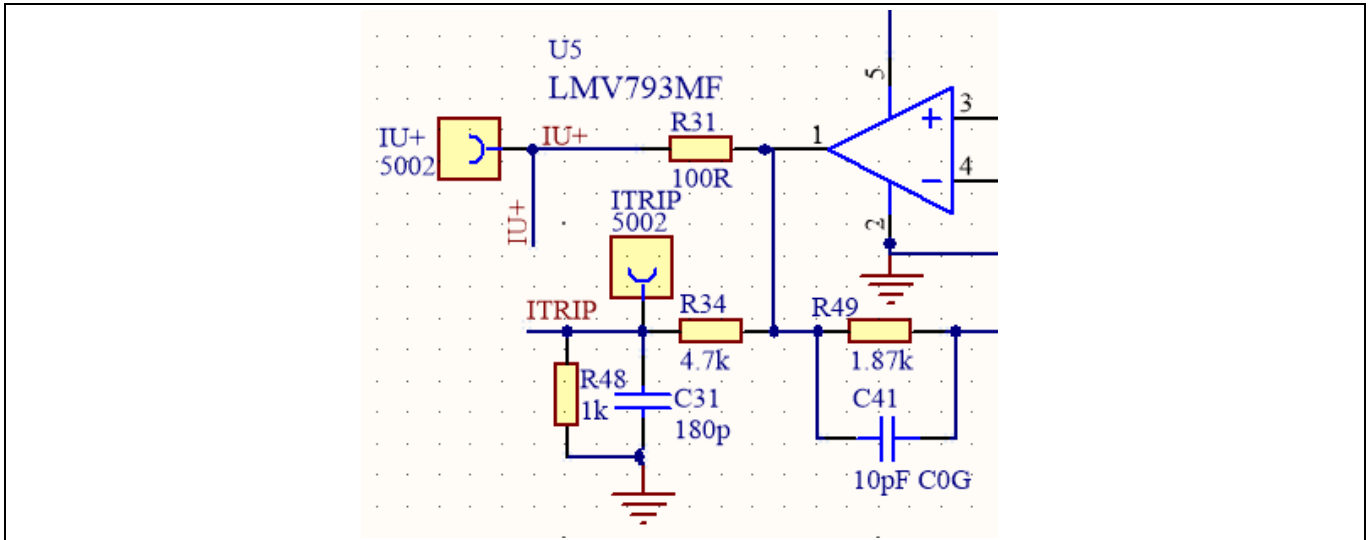

Figure 23 Over-current protection circuit and ITRIP signal

IM828-XCC provides an over-current detection function by connecting the ITRIP input with the MOSFET drain current feedback. The ITRIP comparator threshold (typ. 0.5 V) is referenced to VSS ground.

The typical over-current threshold (IOCP) is:

$$IOCP = \frac{0.5 \text{ V} \times (R34 + R48)}{R48} - V_0 = 34 \text{ A}$$

When the current is higher than 34 A, it will generate a shutdown for all outputs of the gate driver. The shutdown propagation delay is typically 1 μs.

3.7.2 PWM shut down and GK output

When over-current is detected, the ITRIP voltage is over the threshold value, then C30 will be discharged (GK is open drain), and GK drops to “0”. This GK sends signal to control board via J3. GK “0” status is continuous for about 150 μs. After 150 μs, GK becomes open drain and charges C30 via R20. The R20 and C30 time constant is about 470 μs. Figure 24 shows the ITRIP and GK circuit. Figure 25 shows the over-current protection waveform.

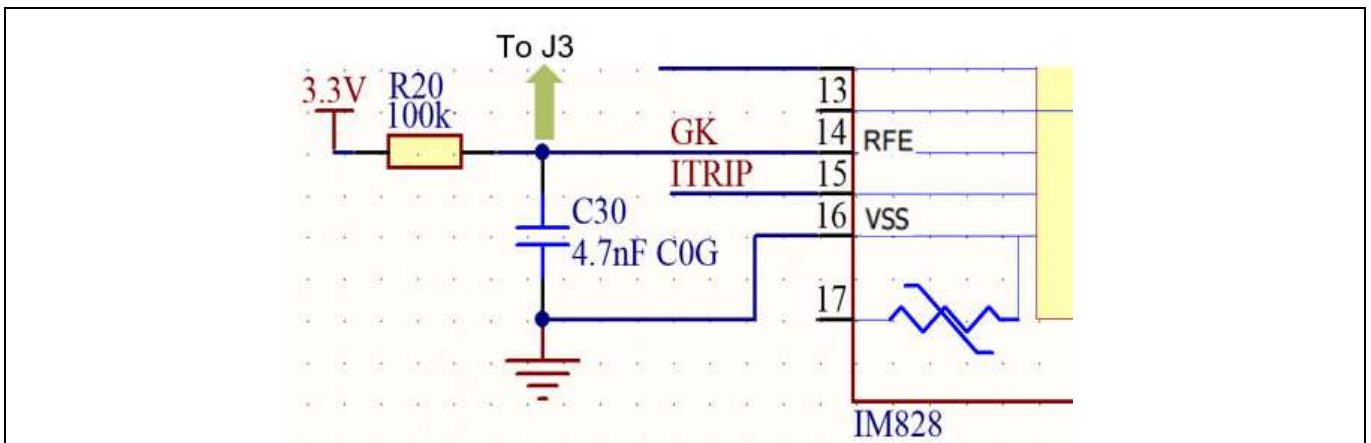

Figure 24 ITRIP / GK and fault-clear

System design



Figure 25 GK and U phase current and voltage waveform in short output on J2

3.8 NTC thermistor characteristics and over-heat protection calculation

Figure 26 shows the NTC measurement circuit.

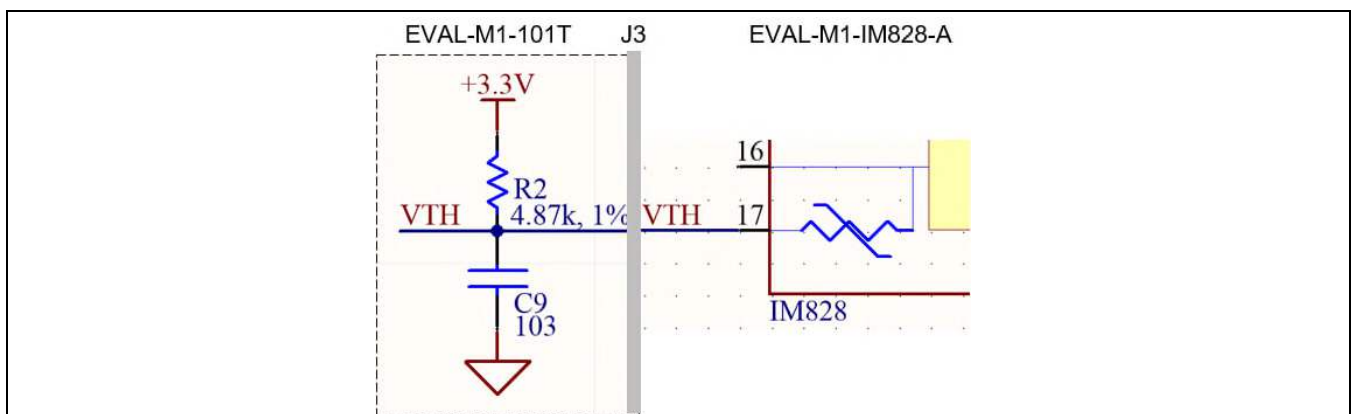

Figure 26 NTC (inside IM828-XCC) connect to EVAL-M1-101T via J3

The NTC is 85 kΩ @ $T_{NTC} = 25^{\circ}\text{C}$, B-constant = 4092 K:

System design

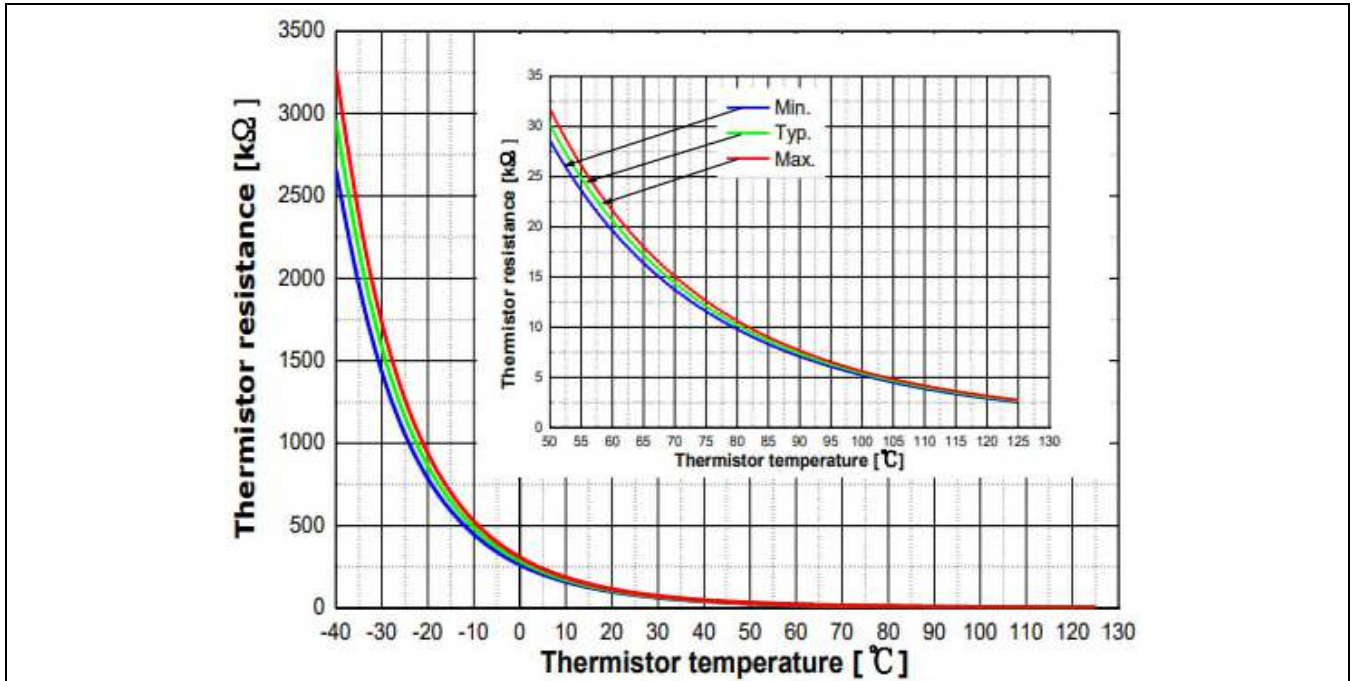

Figure 27 NTC temperature curve and table

Table 6 VTH output vs NTC to EVAL-M1-101T:

Temperature (°C)	NTC (kΩ)	VTH (V)
50	29.97	2.839
60	20.51	2.667
70	14.31	2.462
80	10.16	2.231
90	7.345	1.984
100	5.388	1.733
110	4.009	1.490
120	3.024	1.264
125	2.639	1.160

Figure 28 shows curve of VTH vs NTC

System design

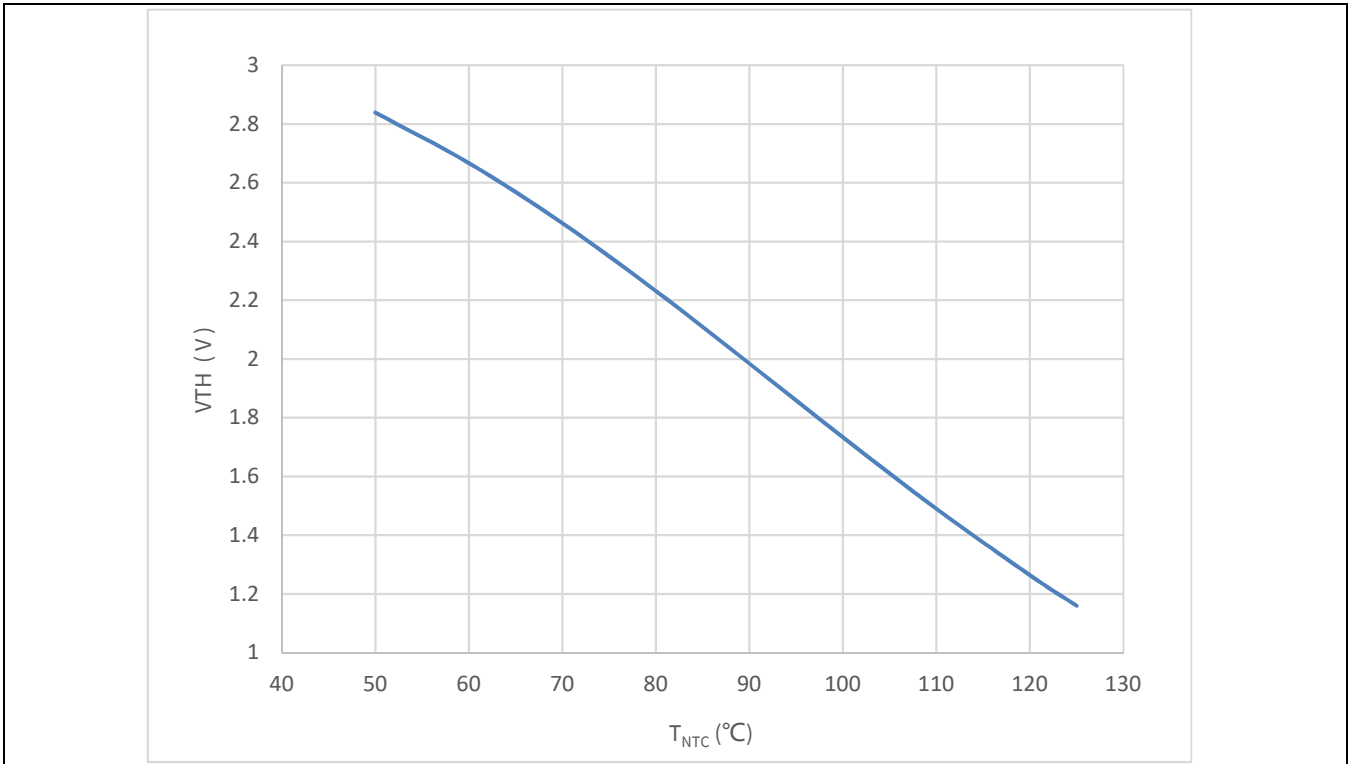

Figure 28 VTH output

Motor 1 Fault Conditions

Question 67 - NTC Temperature Shutdown Value Expand Picture

Set voltage value for NTC Temperature Shutdown if Over Temperature Shutdown is enabled.

If Over Temperature Shutdown is enabled and voltage at AIN pin for NTC is below this value, motor will stop and enter fault state

Answer: V

Figure 29 IPM temperature shutdown set to 100°C in MCEWizard

System design

3.9 Layout

This board has two electrical layers with 70 µm copper (2 oz. copper) and dimensions are 140 mm × 151 mm. The thickness of the PCB board is 1.6 mm. Figure 30 and Figure 31 illustrate the top and bottom layers of the reference design.

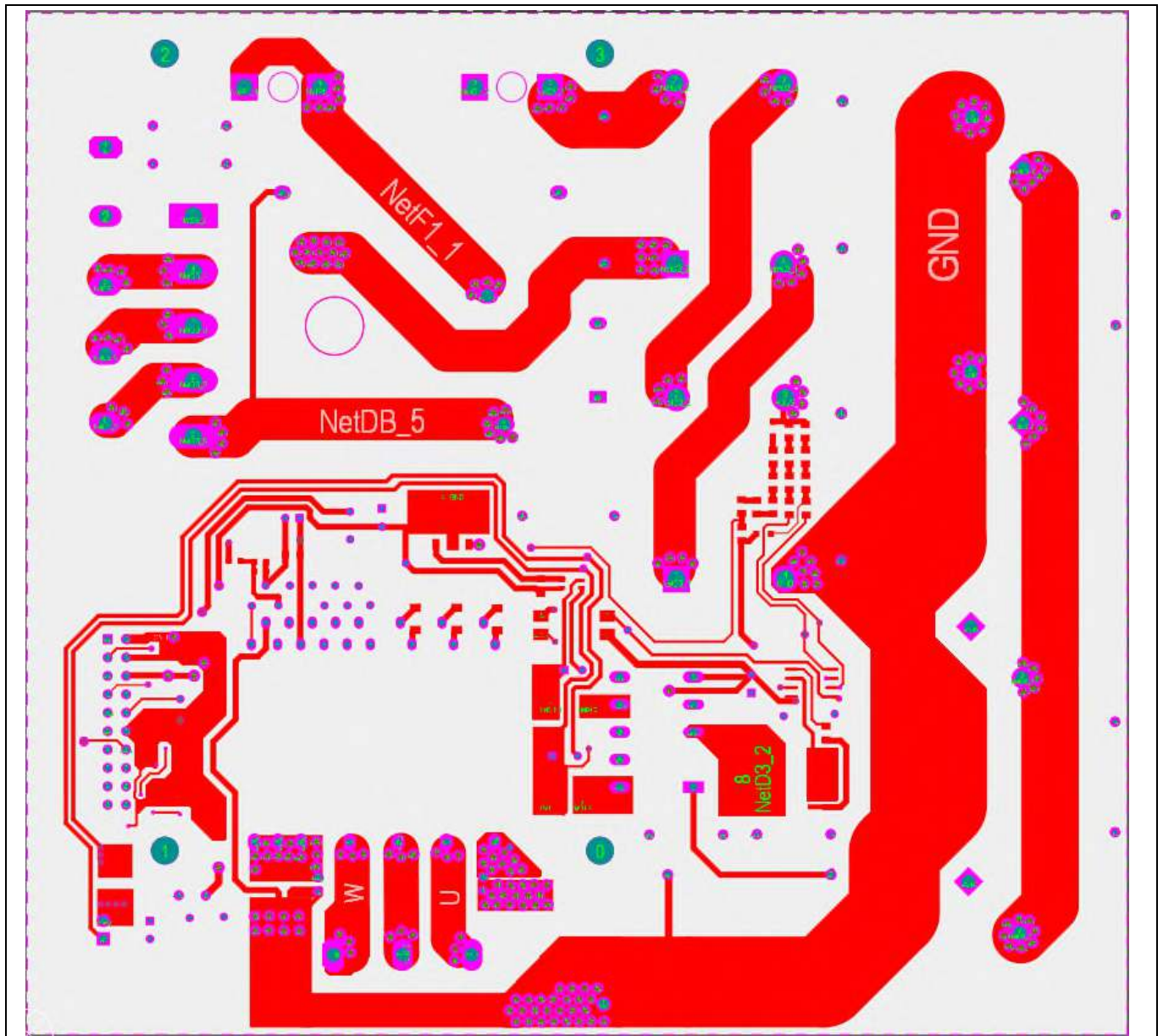

Figure 30 Top layer

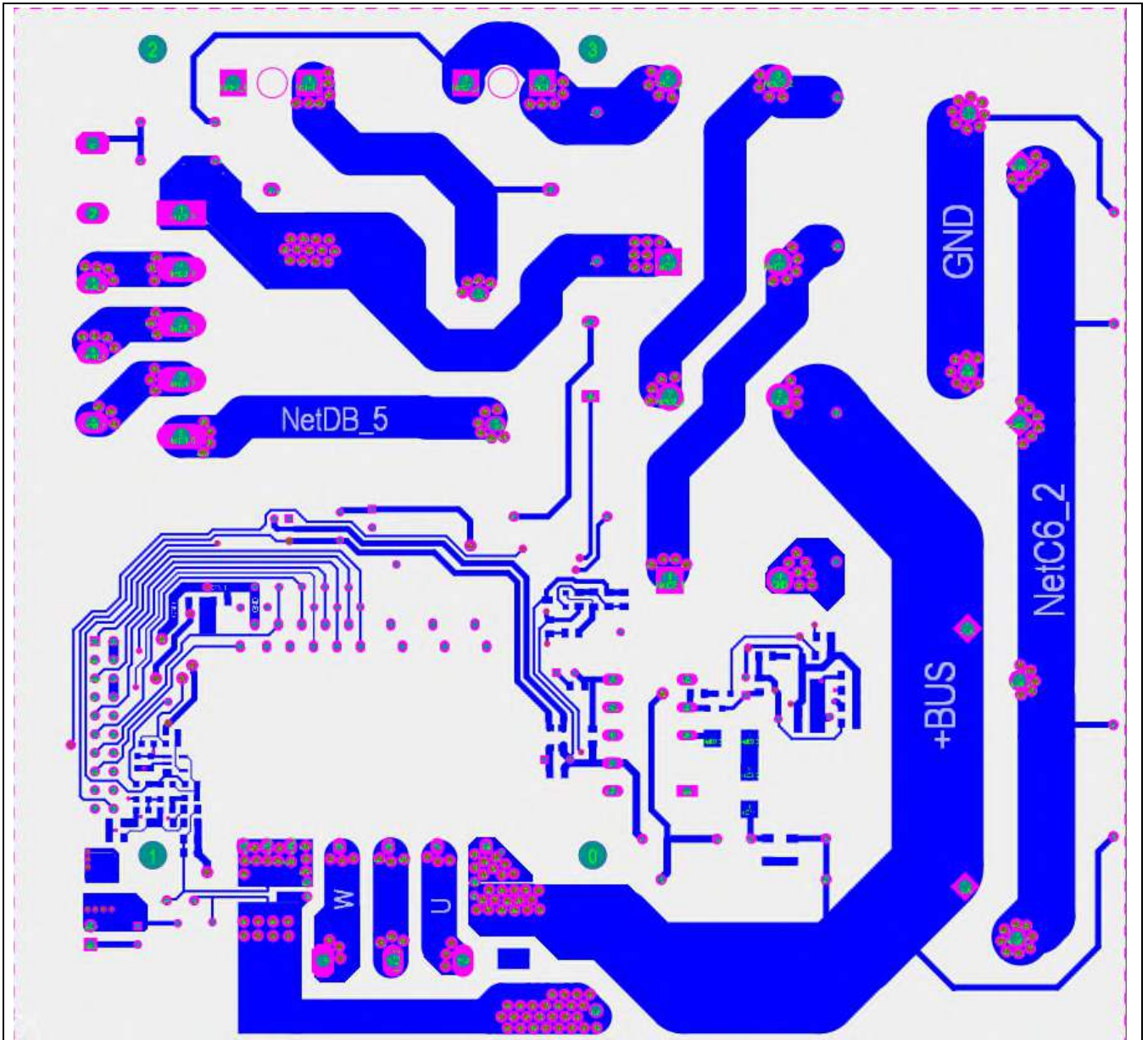

Figure 31 Bottom layer

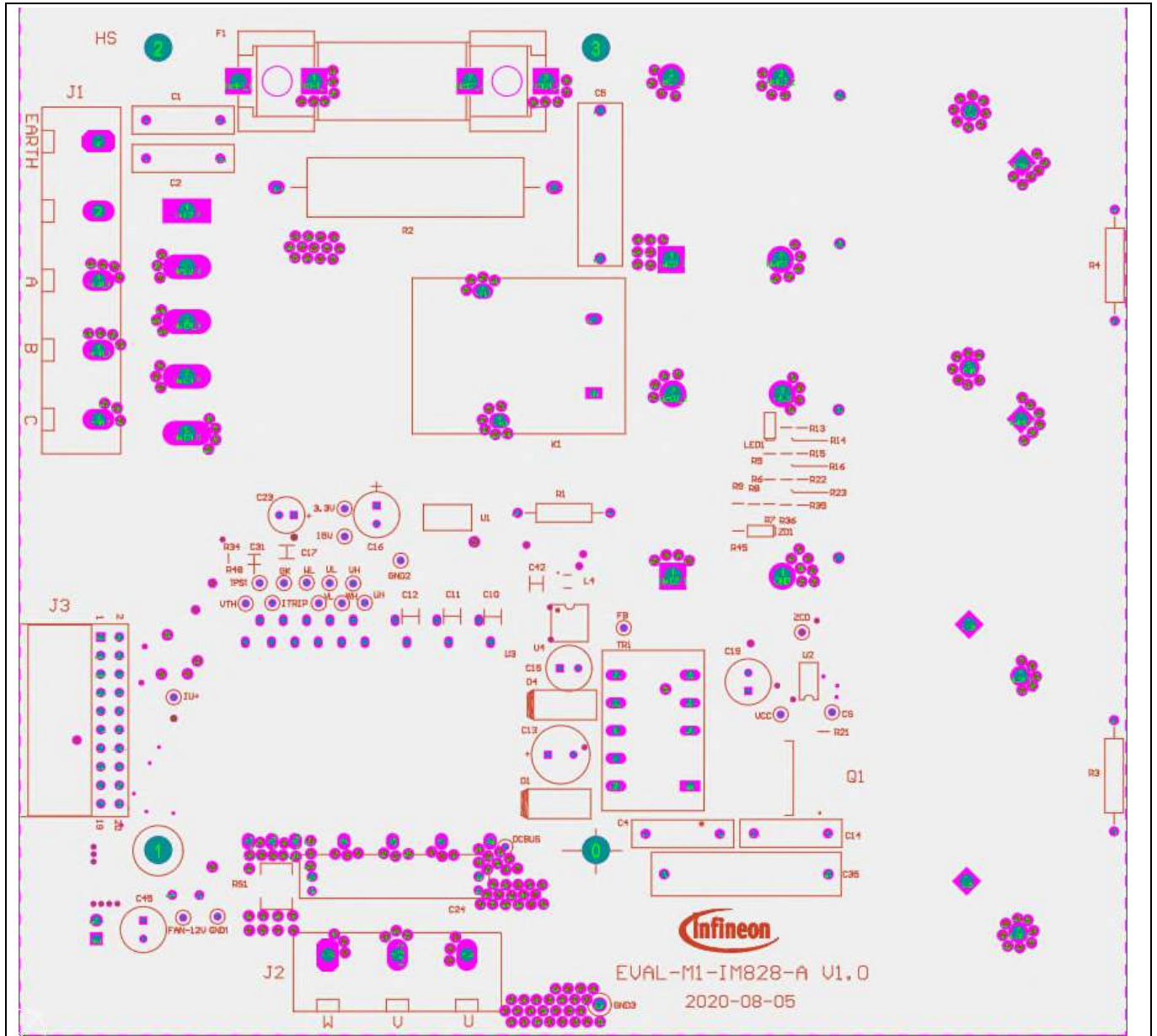

Figure 32 Top over layer

System design

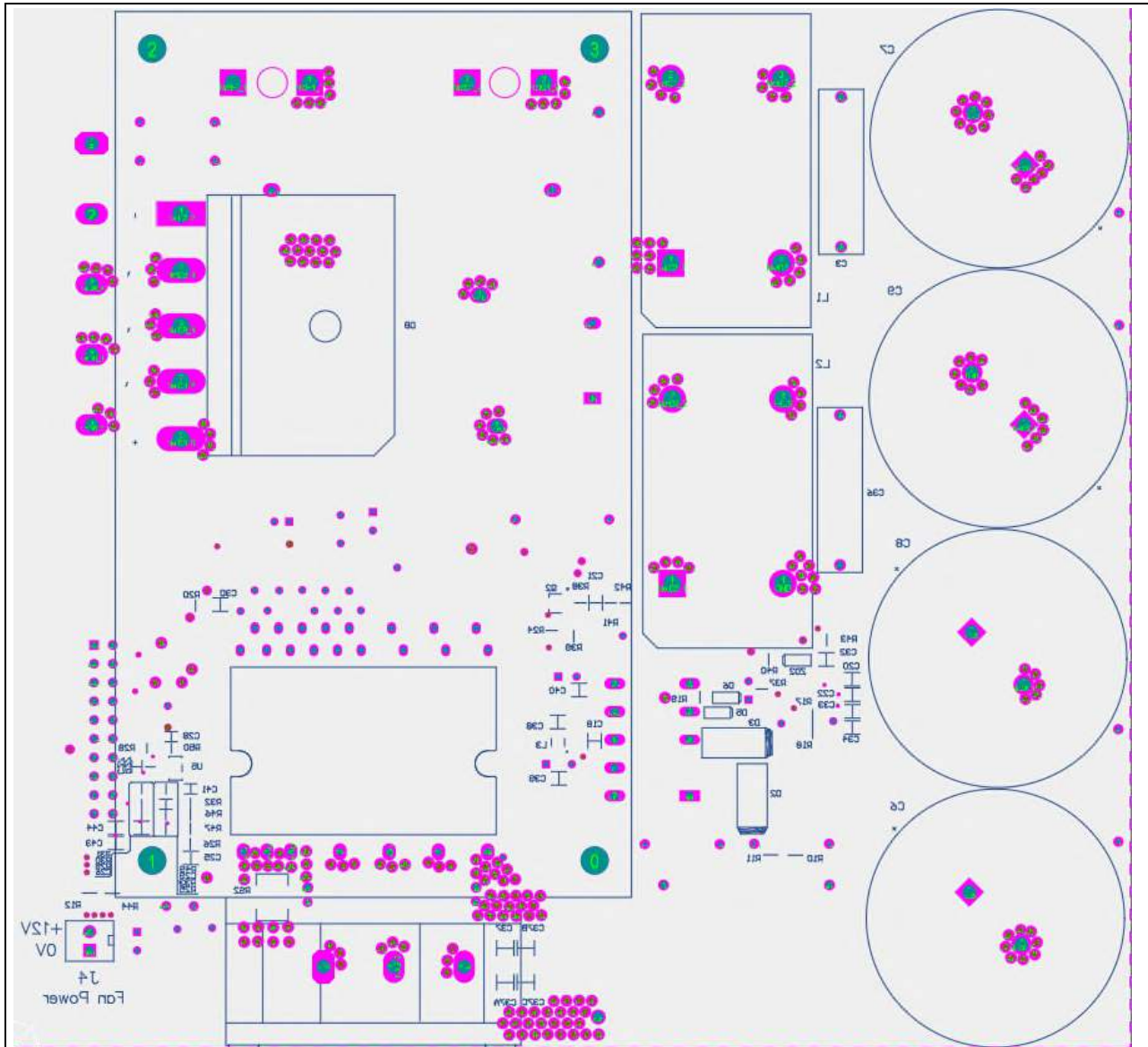

Figure 33 Bottom over layer

3.10 Bill of material

Table 7 shows the major parts of EVAL-M1-IM828-A design.

The complete bill of material is available on the download section of the Infineon homepage. A log-in is required to download this material.

Table 7 BOM of the most important/critical parts of the evaluation board

S. No.	Ref Designator	Description	Manufacturer	Manufacturer P/N
1	U3	CoolSiC™ IPM	Infineon Technologies	IM828-XCC
2	Q1	CoolSiC™ SiC MOSFET 1700 V	Infineon Technologies	IMBF170R1K0M1
3	U2	Quasi-resonant PWM controller	Infineon Technologies	ICE5QSAG

System design

4	U1	Low dropout voltage regulator, 3.3 V output	Infineon Technologies	IFX25001ME V33
5	C6, C7, C8, C9	Electrolytic capacitor	Würth Elektronik	861011486024
6	C13	Electrolytic capacitor	Würth Elektronik	860020474014
7	C15,C45	High endurance radial leaded aluminum electrolytic capacitor	Würth Elektronik	860020474012
8	C16	High endurance radial leaded aluminum electrolytic capacitor	Würth Elektronik	860080374009
9	C23	Miniature aluminum electrolytic capacitor	Würth Elektronik	860080472002
10	J1	5-pin	Würth Elektronik	691210910005
11	J2	Connector	Würth Elektronik	691250910003
12	J3	Connector	Würth Elektronik	613020243121
13	L1, L2	WE-CMB HV common mode	Würth Elektronik /Sunlord	744830007215/ARCD C432340A701N2B
14	L3, L4	WE-CMB HV common mode	Würth Elektronik	744232261
15	TR1	EE20 / 10 / 6	Würth Elektronik	750344164

3.11 Connector details

General information about the connectors of the EVAL-M1-IM828-A evaluation board is provided in the tables below. Table 8 includes the details of the 3-phase AC or DC input connector J1. Table 9 provides the details of the motor side connector J2. Table 10 provides the pin assignments of the iMOTION™ MADK M1 20-pin interface connector J3. This connector is the interface to the control board.

Table 8 J1- 3-phase AC or DC input connector

Pin #	Pin name	Description
1	EARTH	Earth
2	NC	No connection
3	A	AC/DC input
4	B	AC/DC input
5	C	AC/DC input

Table 9 J2- Motor side connector

Pin #	Pin name	Description
1	U	Connected to motor phase U
2	V	Connected to motor phase V
3	W	Connected to motor phase W

System design

Table 10 J3- iMOTION™ MADK M1 20-pin interface connector for power board

Pin #	Pin name	Description
1	PWМУH	3.3 V compatible logic input for high-side gate driver-Phase U
2	GND	Ground
3	PWМУL	3.3 V compatible logic input for low-side gate driver-Phase U
4	GND	Ground
5	PWМVH	3.3 V compatible logic input for high-side gate driver-Phase V
6	+3.3 V	3.3 V power supply
7	PWМVL	3.3 V compatible logic input for low-side gate driver-Phase V
8	+3.3 V	3.3 V power supply
9	PWМWH	3.3 V compatible logic input for high-side gate driver-Phase W
10	IU+	Shunt voltage+
11	PWМWL	3.3 V compatible logic input for low-side gate driver-Phase W
12	IU-	Ground
13	GK	Gatekill
14	DCBSENSE	Input, DC bus voltage to AIN1 after 2000 kΩ registers
15	VTH	Input, voltage input of power module's temperature sense
16	IV+	Open
17	IV-	Open
18	IW+	Open
19	IW-	Open
20	VCC	Defined for 15 V power supply

System performance

4 System performance

4.1 Type output waveform at 3-phase AC380 V input

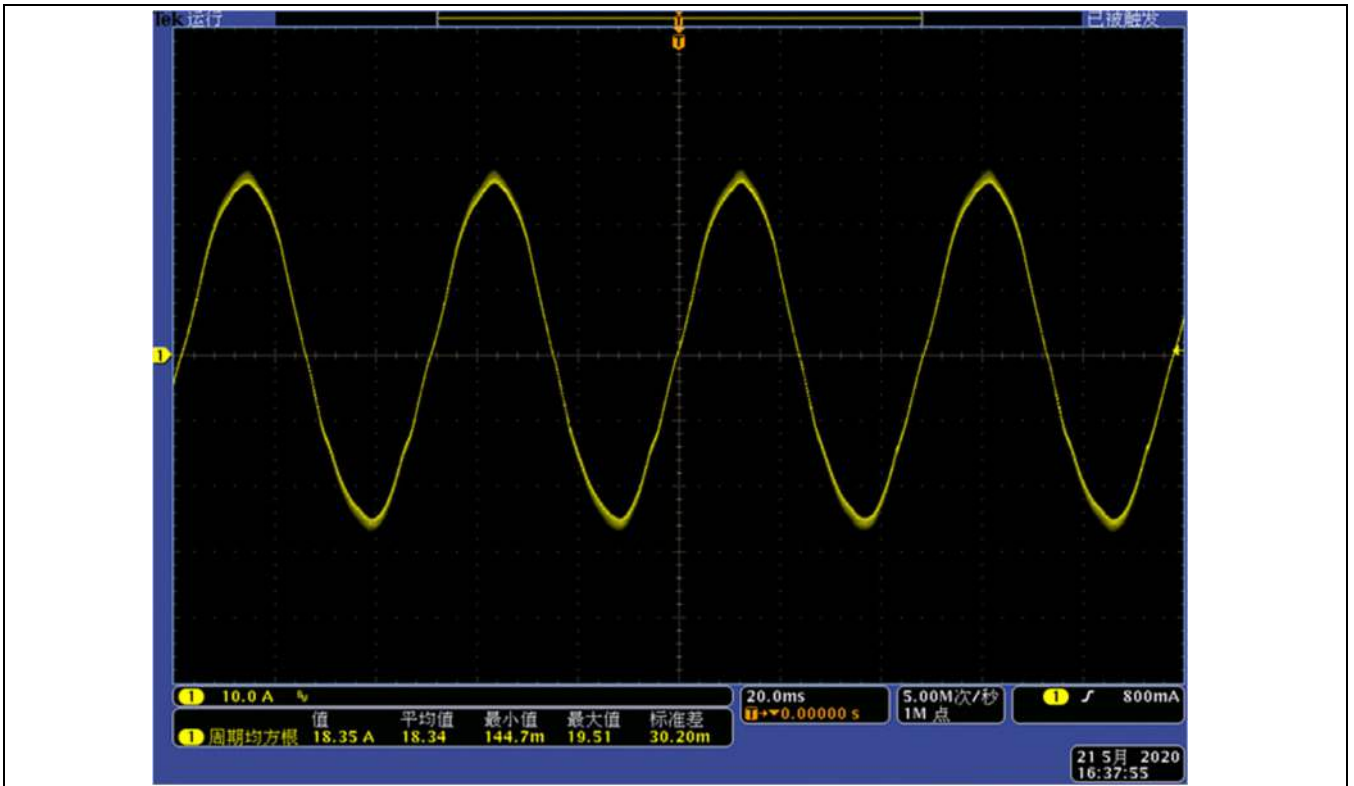

Figure 34 I_u Output 18.35 A at PWM=6 kHz waveform by DPO4104(oscilloscope) + TCP0030(probe)

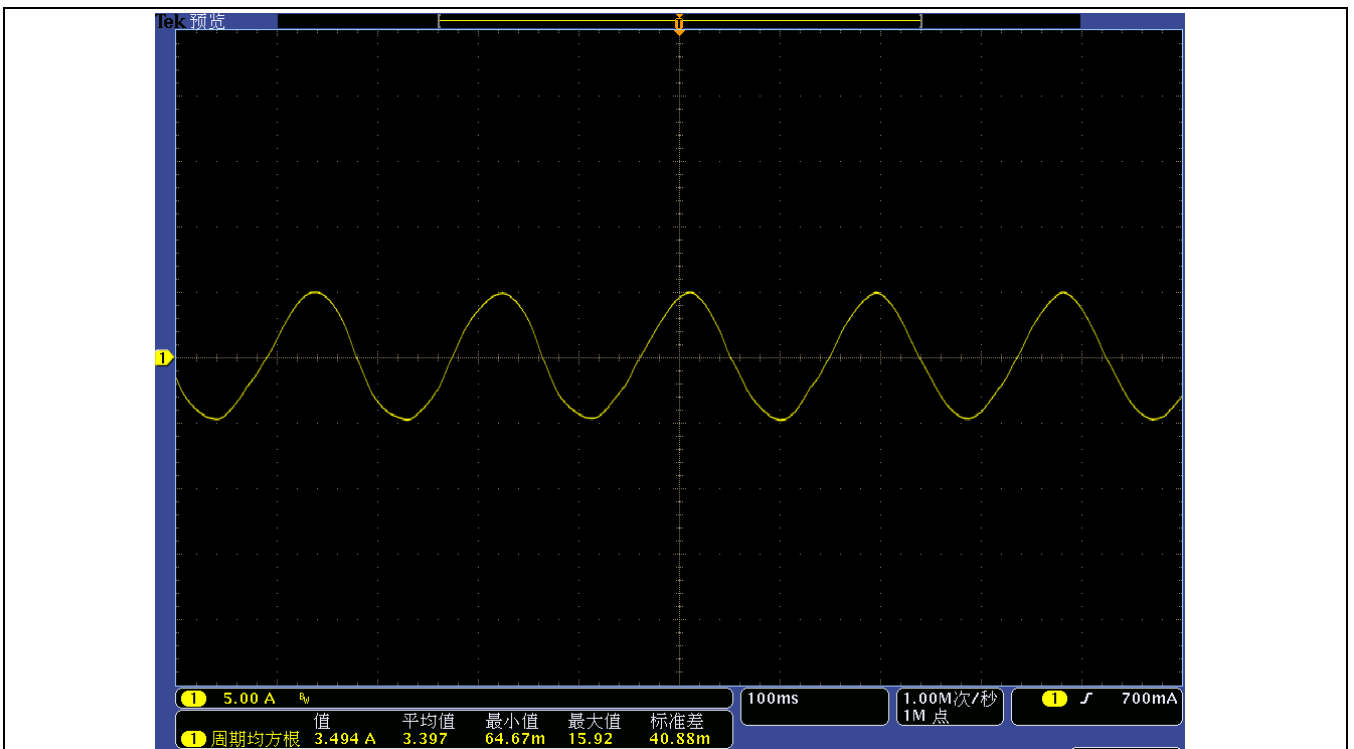

Figure 35 I_u Output 3.5 A at PWM=6 kHz waveform by DPO4104(oscilloscope) + TCP0030(probe)

System performance

4.2 Test results for over-current protection

Figure 36 is the EVAL-M1-IM828-A over-current detection function by connecting the ITRIP input with the IM828-XCC current feedback, and CoolSiC™ MOSFET short-circuit withstand time is about 1.8 μs. Over current detection generates a shutdown of outputs of the gate driver if ITRIP pin input is over 525 mV and lasts longer than 500 ns.

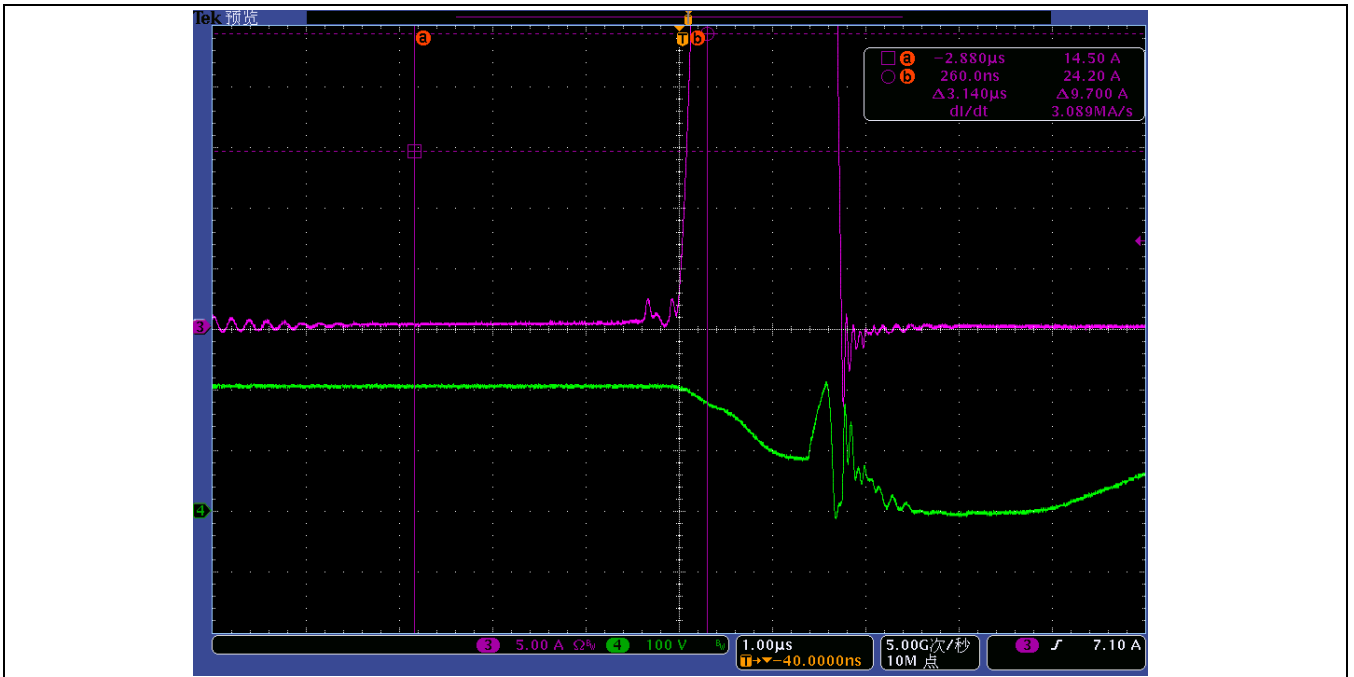

Figure 36 Over-current protection response waveform (CH3: over-current CH4: output voltage)

4.3 T_{cmaxi} vs I_{out} at different PWM frequencies

Figure 37 shows the IPM case temperature vs output current with difference PWM carrier frequencies.

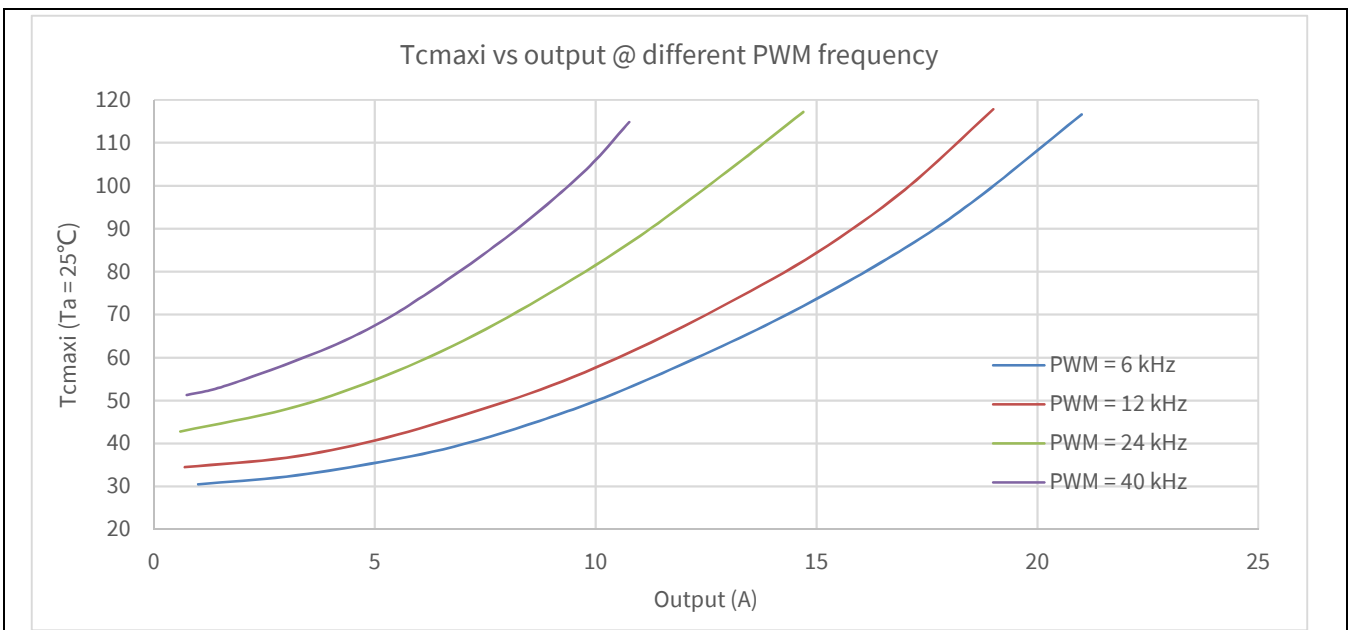

Figure 37 IM828-XCC case temperature vs output power current at different PWM frequencies @380 V AC input, T_a=25°C

System performance

4.4 IM828-XCC's efficiency

Figure 38 shows the IPM efficiency vs output current at 380 V AC input and 6 kHz carrier frequency

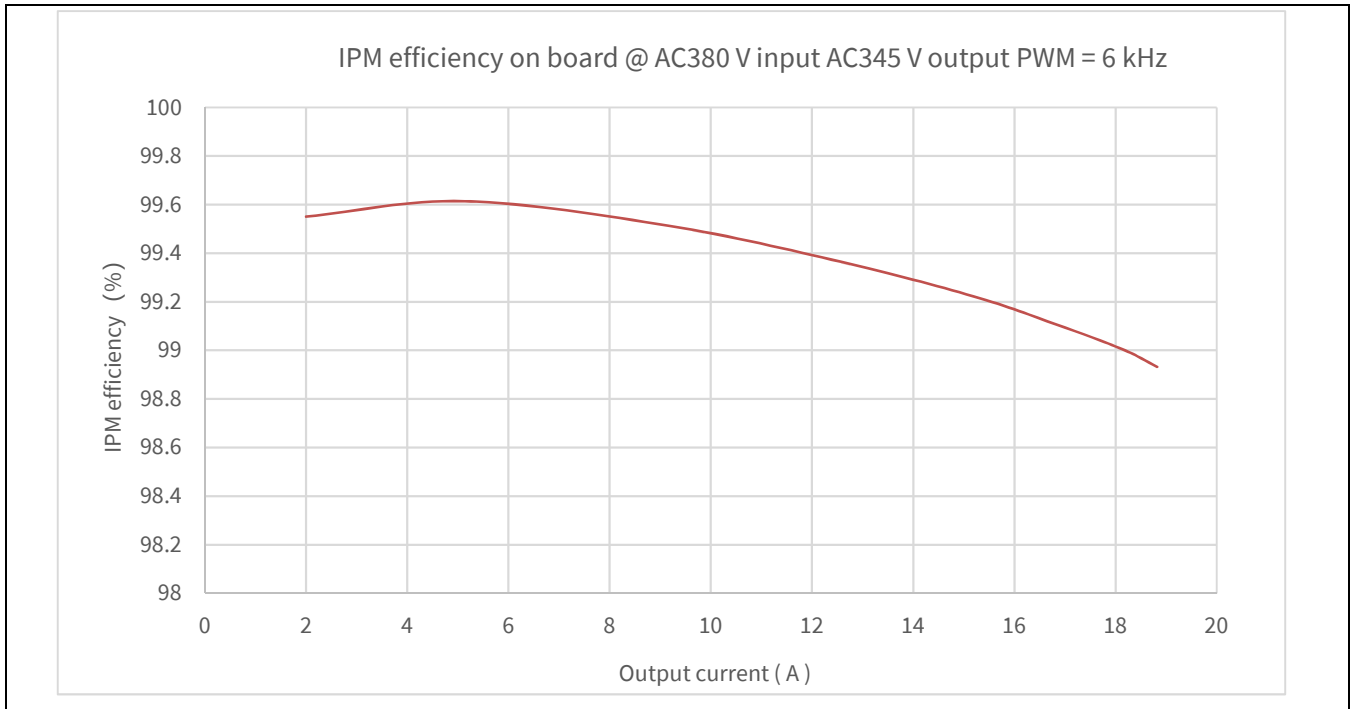

Figure 38 IM828-XCC efficiency vs output current @ 380 V AC input, output 342 V AC, 6 kHz

5 References and appendices

5.1 Abbreviations and definitions

Table 11 Abbreviations

Abbreviation	Meaning
MADK	Modular application design kit
CE	Conformité européenne
EMI	Electromagnetic interference
UL	Underwriters laboratories
OPA	Operational amplifier
LPF	Low-pass filter

5.2 References

- [1] Infineon Technologies AG. Datasheet of Infineon IM828-XCC Datasheet (2020). V2.0 www.infineon.com
- [2] Infineon Technologies AG. Datasheet of Infineon IMC101T Datasheet (2020). V1.6 <https://infineon.com>

5.3 Additional information

The power board is now available for customers in small order quantities. In order to initiate the testing, customers are advised to order the following items:

Table 12 Ordering information

Part number	Symbol	Package	Quantity
EVAL-M1-IM828-A		Boxed	1
IM828-XCC	U3	DIP 36x23D	1
ICE5QSAG	U2	PG-DSO-8	1
IMBF170R1K0M1	Q1	PG-TO263-7	1

Revision history

Revision history

Document version	Date of release	Description of changes
V1.0	2020-10-09	First release

Trademarks

All referenced product or service names and trademarks are the property of their respective owners.

Edition 2020-10-09

Published by

Infineon Technologies AG

81726 Munich, Germany

© 2020 Infineon Technologies AG.

All Rights Reserved.

Do you have a question about this document?

Email: erratum@infineon.com

Document reference

UG-2020-27

For further information on the product, technology, delivery terms and conditions and prices please contact your nearest Infineon Technologies office (www.infineon.com).

WARNINGS

Due to technical requirements products may contain dangerous substances. For information on the types in question please contact your nearest Infineon Technologies office.

Except as otherwise explicitly approved by Infineon Technologies in a written document signed by authorized representatives of Infineon Technologies, Infineon Technologies' products may not be used in any applications where a failure of the product or any consequences of the use thereof can reasonably be expected to result in personal injury.