

RECOMMENDED PCB LAYOUT AND KEEP-OUT ZONE

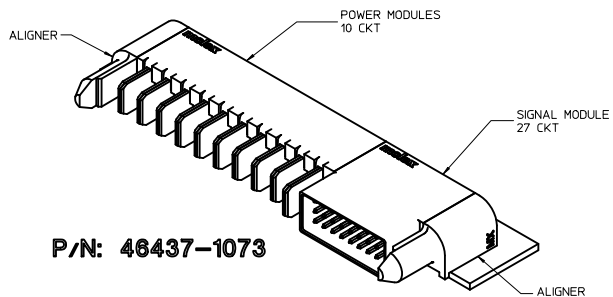
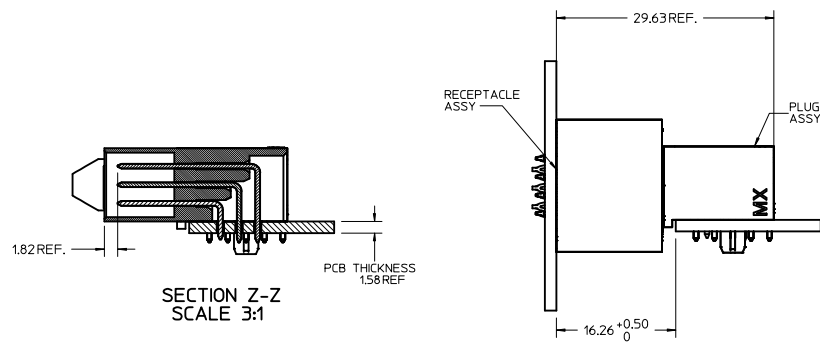
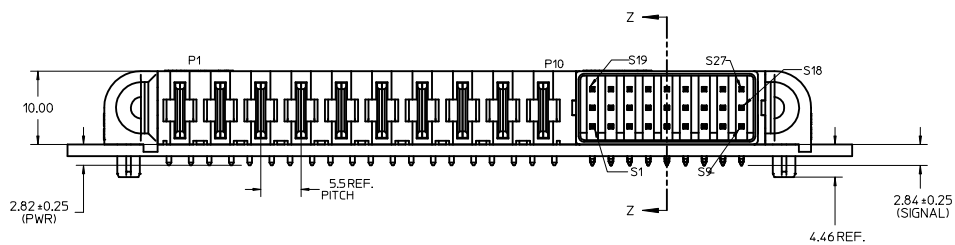

NOTES:

- MATERIAL:
 - HOUSINGS: LCP UL-94, V-0, COLOR: BLACK
 - TERMINALS: COPPER ALLOY
 - PLATING: .00127 NICKEL OVERALL WITH 0.00254 SELECTIVE TIN ON SOLDER TAILS AND 0.000762 SELECTIVE GOLD ON CONTACT AREA.
- PACKAGING: ASSEMBLIES TO BE TRAY PACKED, QTY TBD.
- PRODUCT SPEC: PS-46436-100.
- APPLICATION SPEC: AS-46436-100.
- PC BOARD REQUIRES SOLDER THRU HOLES, REFER TO PS-46436-100 FOR DETAILS.
- PRODUCT TO MEET ROHS REQUIREMENTS.
- ASSEMBLY MATES TO MOLEX VERTICAL RECEPTACLE ASSEMBLY P/N: 46562-1073.

P1 & P10 REVERSED EC NO. UCP2010-1478 DRAWN BY CHYD/BKOSTIC 2009/11/24 CHECKED BY CHYD/BKOSTIC 2010/01/21 APPR:APATEL 2010/02/10 REV DESCRIPTION	QUALITY SYMBOLS		GENERAL TOLERANCES (UNLESS SPECIFIED)		DIMENSION STYLE		SCALE	DESIGN UNITS	THIRD ANGLE PROJECTION
			mm INCH		MM ONLY		2:1	METRIC	
	4 PLACES	±	---	±	---	DRAWN BY BKOSTIC	DATE 4/21/09	TITLE	
	3 PLACES	±	---	±	---	CHECKED BY BKOSTIC	DATE 4/21/09	RA PLUG ASSY 10P-27S TEN60 POWER FAMILY	
2 PLACES	±	0.25	±	---	APPROVED BY	DATE	MOLEX MOLEX INCORPORATED		
1 PLACE	±	0.25	±	---	ANGULAR ±1/2°				
DRAFT WHERE APPLICABLE MUST REMAIN WITHIN DIMENSIONS					MATERIAL NO. 46437-1073		DOCUMENT NO. SD-46437-1073		SHEET NO. 1 OF 1
THIS DRAWING CONTAINS INFORMATION THAT IS PROPRIETARY TO MOLEX INCORPORATED AND SHOULD NOT BE USED WITHOUT WRITTEN PERMISSION									