



SANYO Semiconductors

# DATA SHEET

An ON Semiconductor Company

Monolithic Digital IC

## LB1973M — Two-channel H-Bridge Driver

### Overview

The LB1973M is a two-channel H-bridge driver that supports for low saturation drive operation. It is optimal for H-bridge drive of stepping motors (AF and zoom) in portable equipment such as camera cell phones.

### Features

- Two-channel H-bridge driver
- The range of the operation voltage is wide.(1.8V to 7.5V)
- Small package : MFP10S(225mil)
- Built-in thermal protection

### Specifications

**Absolute Maximum Ratings** at  $T_a = 25^\circ\text{C}$

Parameter	Symbol	Conditions	Ratings	Unit
Maximum supply voltage	$V_{CC}$ max		-0.3 to +8.0	V
Output voltage	$V_{OUT}$ max		-0.3 to $V_{CC}+V_{SF}$	V
Input voltage	$V_{IN}$ max	CONT, IN	-0.3 to +8.0	V
Ground pin source current	$I_{GND}$	Per channel	1000	mA
Allowable power dissipation	$P_d$ max1	For Unit	350	mW
	$P_d$ max2	Mounted on a circuit board.*	870	mW
Operating temperature	$T_{opr}$		-20 to +85	$^\circ\text{C}$
Storage temperature	$T_{stg}$		-40 to +150	$^\circ\text{C}$

\* Mounted on a Specified board : 114.3mm×76.1mm×1.6mm, glass epoxy

**Allowable Operating Ratings** at  $T_a = 25^\circ\text{C}$

Parameter	Symbol	Conditions	Ratings	Unit
Supply voltage	$V_{CC}$		1.8 to 7.5	V
High-level input voltage	$V_{IH}$		1.3 to 7.5	V
Low-level input voltage	$V_{IL}$		-0.3 to +0.5	V

■ Any and all SANYO Semiconductor Co.,Ltd. products described or contained herein are, with regard to "standard application", intended for the use as general electronics equipment (home appliances, AV equipment, communication device, office equipment, industrial equipment etc.). The products mentioned herein shall not be intended for use for any "special application" (medical equipment whose purpose is to sustain life, aerospace instrument, nuclear control device, burning appliances, transportation machine, traffic signal system, safety equipment etc.) that shall require extremely high level of reliability and can directly threaten human lives in case of failure or malfunction of the product or may cause harm to human bodies, nor shall they grant any guarantee thereof. If you should intend to use our products for applications outside the standard applications of our customer who is considering such use and/or outside the scope of our intended standard applications, please consult with us prior to the intended use. If there is no consultation or inquiry before the intended use, our customer shall be solely responsible for the use.

■ Specifications of any and all SANYO Semiconductor Co.,Ltd. products described or contained herein stipulate the performance, characteristics, and functions of the described products in the independent state, and are not guarantees of the performance, characteristics, and functions of the described products as mounted in the customer's products or equipment. To verify symptoms and states that cannot be evaluated in an independent device, the customer should always evaluate and test devices mounted in the customer's products or equipment.

**SANYO Semiconductor Co., Ltd.**

<http://semicon.sanyo.com/en/network>

# LB1973M

**Electrical Characteristics** at  $T_a = 25^\circ\text{C}$ ,  $V_{CC} = 1.9\text{V}$

Parameter	Symbol	Conditions	Ratings			Unit
			min	typ	max	
Source current	$I_{CCO1}$	$V_{CC} = 1.9\text{V}, IN1 \text{ to } IN4 = 0\text{V}$		0.01	1	$\mu\text{A}$
	$I_{CCO2}$	$V_{CC} = 3\text{V}, IN1 \text{ to } IN4 = 0\text{V}$		0.01	1	$\mu\text{A}$
	$I_{CC1}$	$IN1 = 1.9\text{V}, IN2 \text{ to } IN4 = 0\text{V}$		18	25	$\text{mA}$
	$I_{CC2}$	$IN1 = 3\text{V}, IN2 \text{ to } IN4 = 0\text{V}, V_{CC} = 3\text{V}$		19	26	$\text{mA}$
Output saturation voltage1 (single connection)	$V_{OUT11}$	$I_{OUT} = 270\text{mA}, V_{CC} = 1.9\text{V to } 3.6\text{V}, V_{OUT} =$ Upper Tr and Under Tr $IN1 = 1.3\text{V}, IN2 \text{ to } IN4 = 0\text{V}$ Supplementation: Standard similar as for IN2 to IN4 = 1.3V		0.2	0.3	V
	$V_{OUT12}$	$I_{OUT} = 350\text{mA}, V_{CC} = 1.9\text{V to } 3.6\text{V}, V_{OUT} =$ Upper Tr and Under Tr $IN1 = 1.3\text{V}, IN2 \text{ to } IN4 = 0\text{V}$ Supplementation: Standard similar as for IN2 to IN4 = 1.3V		0.25	0.4	V
Output saturation voltage2 (parallel connection)	$V_{OUT21}$	$I_{OUT} = 270\text{mA}, V_{CC} = 1.9\text{V to } 3.6\text{V}, V_{OUT} =$ Upper Tr and Under Tr OUT1-3, OUT2-4 short. $IN1 \text{ and } IN3 =$ $1.3\text{V}, IN2 \text{ and } IN4 = 0\text{V}$ Supplementation: Standard similar as for IN2 and IN4 = 1.3V		0.12	0.2	V
	$V_{OUT22}$	$I_{OUT} = 500\text{mA}, V_{CC} = 1.9\text{V to } 3.6\text{V}, V_{OUT} =$ Upper Tr and Under Tr OUT1-3, OUT2-4 short. $IN1 \text{ and } IN3 =$ $1.3\text{V}, IN2 \text{ and } IN4 = 0\text{V}$ Supplementation: Standard similar as for IN2 and IN4 = 1.3V		0.2	0.35	V
Input current	$I_{IN}$	$V_{IN} = 1.9\text{V}$		32	70	$\mu\text{A}$
Thermal shutdown operation temperature	$T_{tsd}$			140		$^\circ\text{C}$
Temperature hysteresis width	$\Delta T$			20		$^\circ\text{C}$
Spark killer Diode						
Reverse current	$I_S(\text{leak})$	$V_{CC-OUT} = 8\text{V}, V_{IN} = 0\text{V}$			10	$\mu\text{A}$
Forward voltage	$V_{SF}$	$I_{OUT} = 400\text{mA}, V_{IN} = 0\text{V}$			1.7	V

## Package Dimensions

unit : mm (typ)

3086B

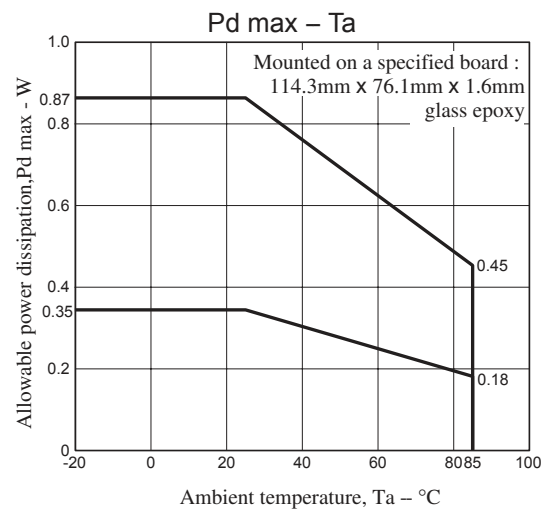
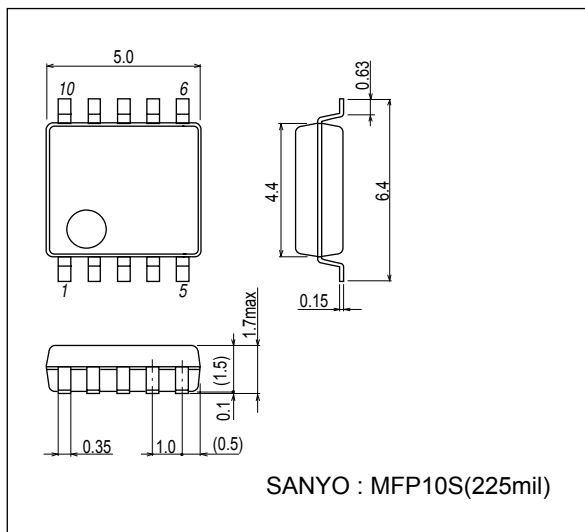

# LB1973M

## Pin Assignment

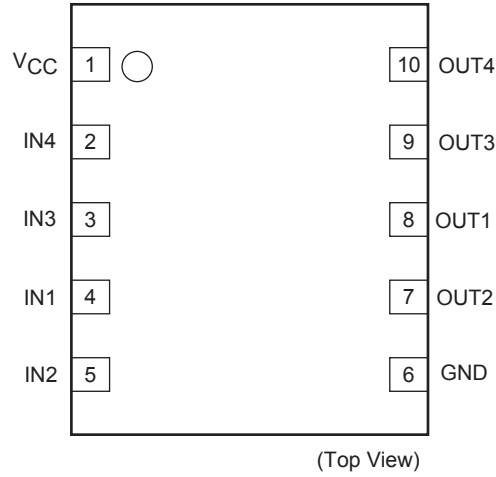

## Truth Table

Input				Output				Mode
IN1	IN2	IN3	IN4	OUT1	OUT2	OUT3	OUT4	
Low	Low	Low	Low	Off	Off	Off	Off	Standby mode
High	Low	-	-	High	Low	-	-	Channel 1, forward
Low	High			Low	High			Channel 1, reverse
-	-	High	Low	-	-	High	Low	Channel 2, forward
		Low	High			Low	High	Channel 2, reverse
High	High	-	-	The logic output for the first high-level input is produced.				
-	-	High	High					

## Block Diagram

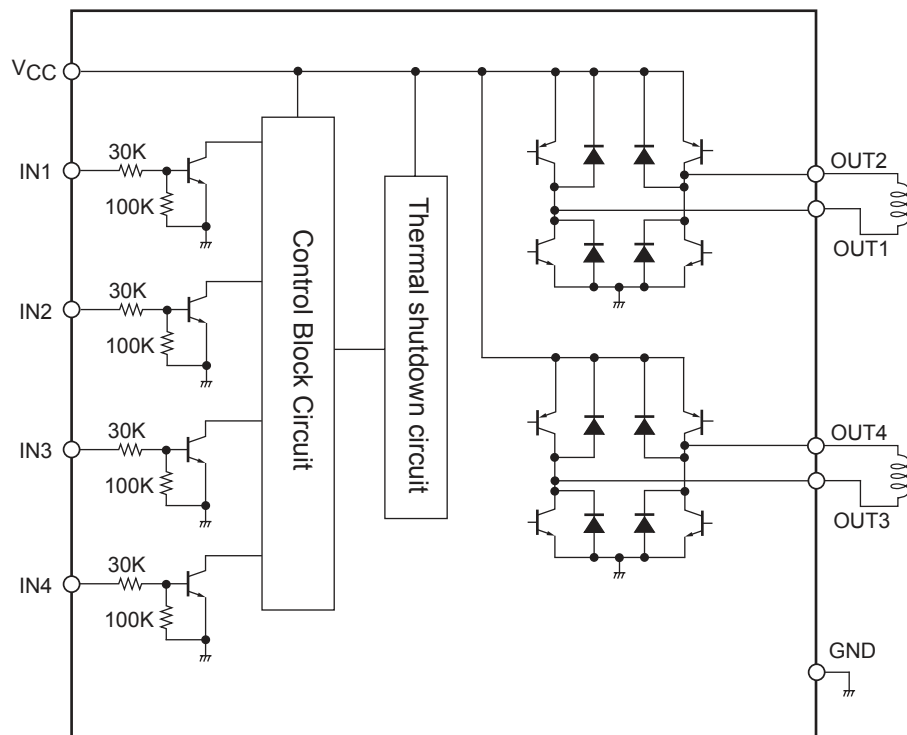

Timing Chart

(1) Stepper motor timing chart  
Timing chart for 2-phase drive

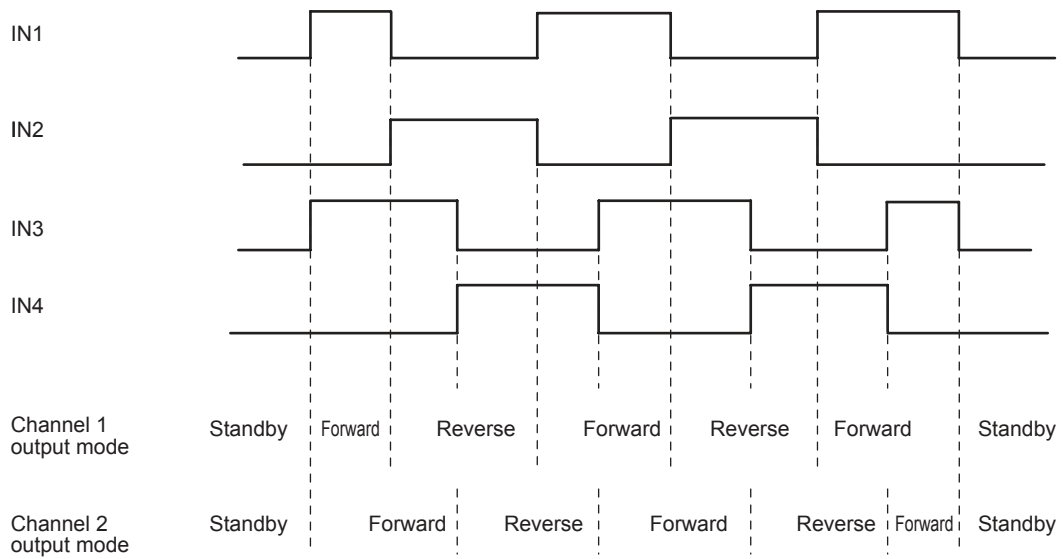

(2) Timing chart for 1-2 phase drive (Fastdecay mode)

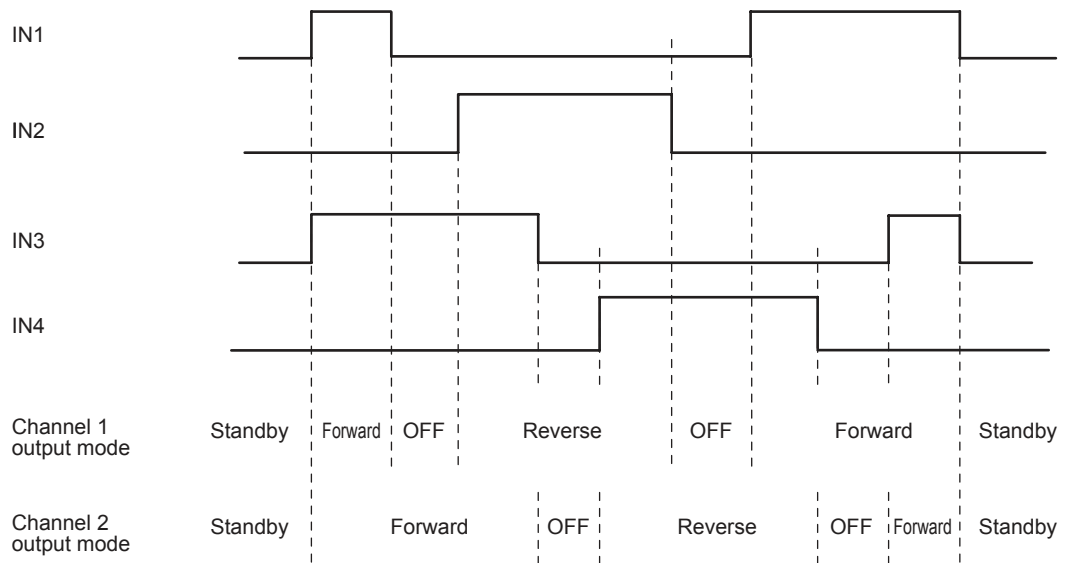

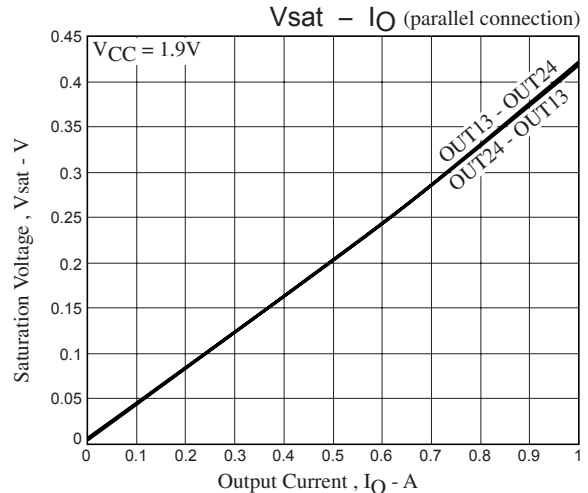
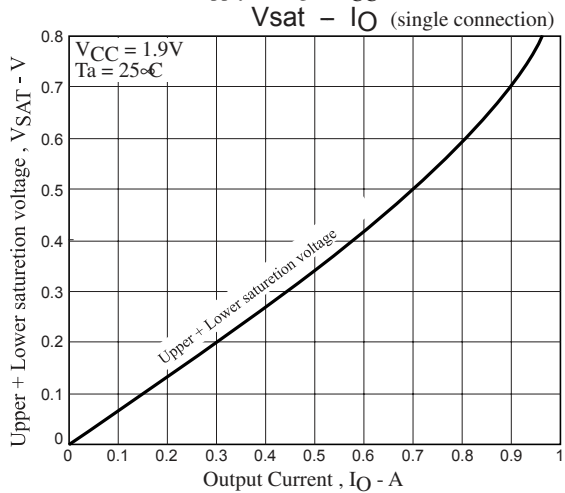
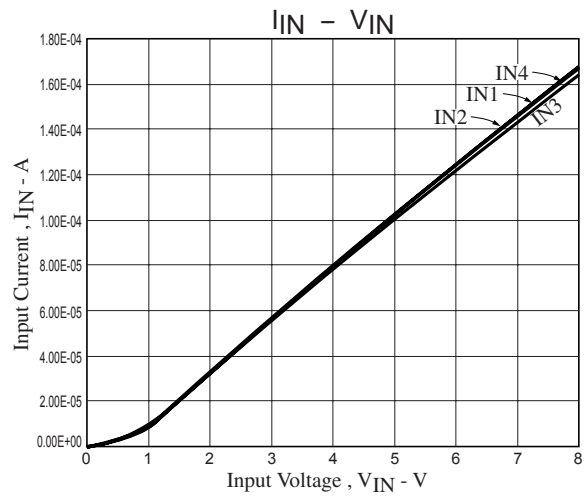
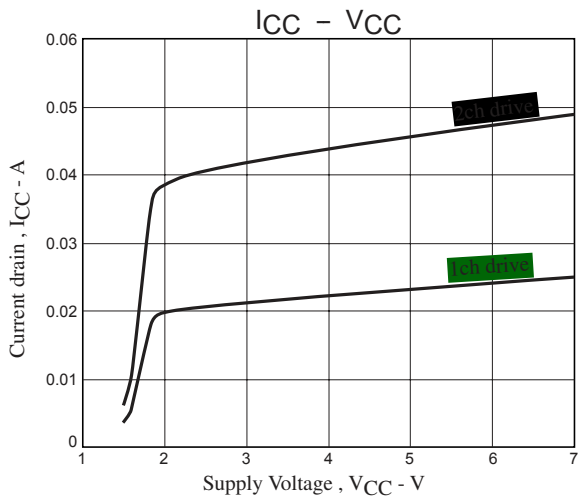

- SANYO Semiconductor Co.,Ltd. assumes no responsibility for equipment failures that result from using products at values that exceed, even momentarily, rated values (such as maximum ratings, operating condition ranges, or other parameters) listed in products specifications of any and all SANYO Semiconductor Co.,Ltd. products described or contained herein.
- SANYO Semiconductor Co.,Ltd. strives to supply high-quality high-reliability products, however, any and all semiconductor products fail or malfunction with some probability. It is possible that these probabilistic failures or malfunction could give rise to accidents or events that could endanger human lives, trouble that could give rise to smoke or fire, or accidents that could cause damage to other property. When designing equipment, adopt safety measures so that these kinds of accidents or events cannot occur. Such measures include but are not limited to protective circuits and error prevention circuits for safe design, redundant design, and structural design.
- In the event that any or all SANYO Semiconductor Co.,Ltd. products described or contained herein are controlled under any of applicable local export control laws and regulations, such products may require the export license from the authorities concerned in accordance with the above law.
- No part of this publication may be reproduced or transmitted in any form or by any means, electronic or mechanical, including photocopying and recording, or any information storage or retrieval system, or otherwise, without the prior written consent of SANYO Semiconductor Co.,Ltd.
- Any and all information described or contained herein are subject to change without notice due to product/technology improvement, etc. When designing equipment, refer to the "Delivery Specification" for the SANYO Semiconductor Co.,Ltd. product that you intend to use.
- Information (including circuit diagrams and circuit parameters) herein is for example only; it is not guaranteed for volume production.
- Upon using the technical information or products described herein, neither warranty nor license shall be granted with regard to intellectual property rights or any other rights of SANYO Semiconductor Co.,Ltd. or any third party. SANYO Semiconductor Co.,Ltd. shall not be liable for any claim or suits with regard to a third party's intellectual property rights which has resulted from the use of the technical information and products mentioned above.

This catalog provides information as of April, 2011. Specifications and information herein are subject to change without notice.