

THE INFORMATION CONTAINED IN THIS DRAWING IS THE SOLE PROPERTY OF ANDERSON POWER PRODUCTS. ANY REPRODUCTION IN PART OR WHOLE WITHOUT THE WRITTEN PERMISSION OF ANDERSON POWER PRODUCTS IS PROHIBITED.

REV.	DESCRIPTION OF CHANGES	BY:	DATE
1	ECRN 13502-.21 WAS .24	CMS	7/2/02
2	ECRN 14110 - REDRAWN	AMS	2/28/07

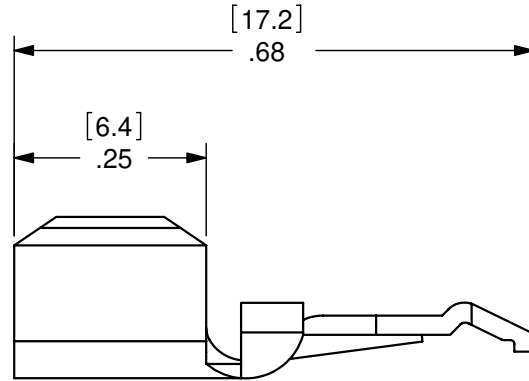
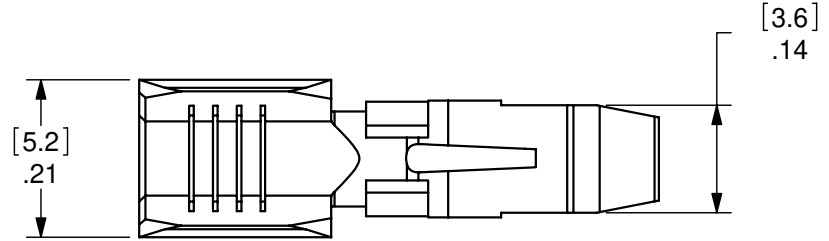
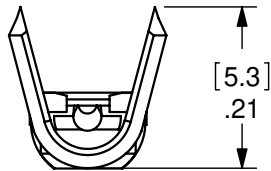
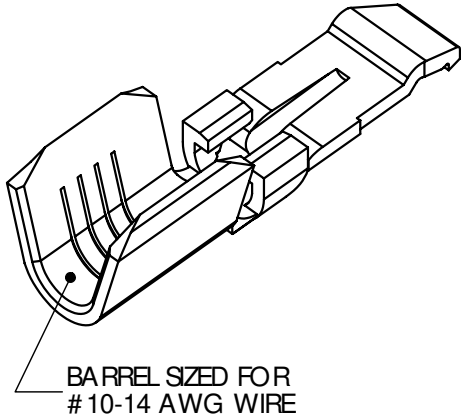

ITEM NO.	PART OR IDENTIFYING NO.	NOMENCLATURE OR DESCRIPTION	MATERIAL SPECIFICATION	QTY REQD
COPYRIGHT 1999 ANDERSON POWER PRODUCTS. ALL RIGHTS RESERVED. UNAUTHORIZED REPRODUCTION HEREBY PROHIBITED.				
DIMENSIONS ARE IN INCHES DIMENSIONS IN PARENTHESES [] ARE IN MILLIMETERS		CAD GENERATED DRAWING, DO NOT MANUALLY UPDATE		ANDERSON POWER PRODUCTS CATALOG NUMBER 269G3 45 AMP HIGH DETENT CONTACT FOR REEL TYPE "F" CRIMP #10-14 WIRE
TOLERANCES ARE: 2PL- ±.02 [±.5]		APPROVALS	DATE	
MATERIALS: <i>COPPER</i>		DRAWN	CMS 6/29/99	
FINISH: <i>HOT TIN DIP</i>		CHECKED	DJD 6/30/99	
NEXT ASSY	USED ON	RESP ENG	UFR 6/30/99	SIZE A SPECIFICATION: 113967S3 REV. 2
APPLICATION	DO NOT SCALE DRAWING	MFG ENG	CHB 6/30/99	
		QUAL ENG	RPO 7/8/99	SCALE NONE
			CADFILES 01063	SHEET 1 OF 1