

THIS DRAWING IS UNPUBLISHED. RELEASED FOR PUBLICATION  
 © COPYRIGHT - By - ALL RIGHTS RESERVED.

LOC		DIST		REVISIONS			
P	LTR	DESCRIPTION	DATE	DWN	APVD		
AD	00	B2	REVISED PER ECO-11-004587	11MAR11	RK	HMR	

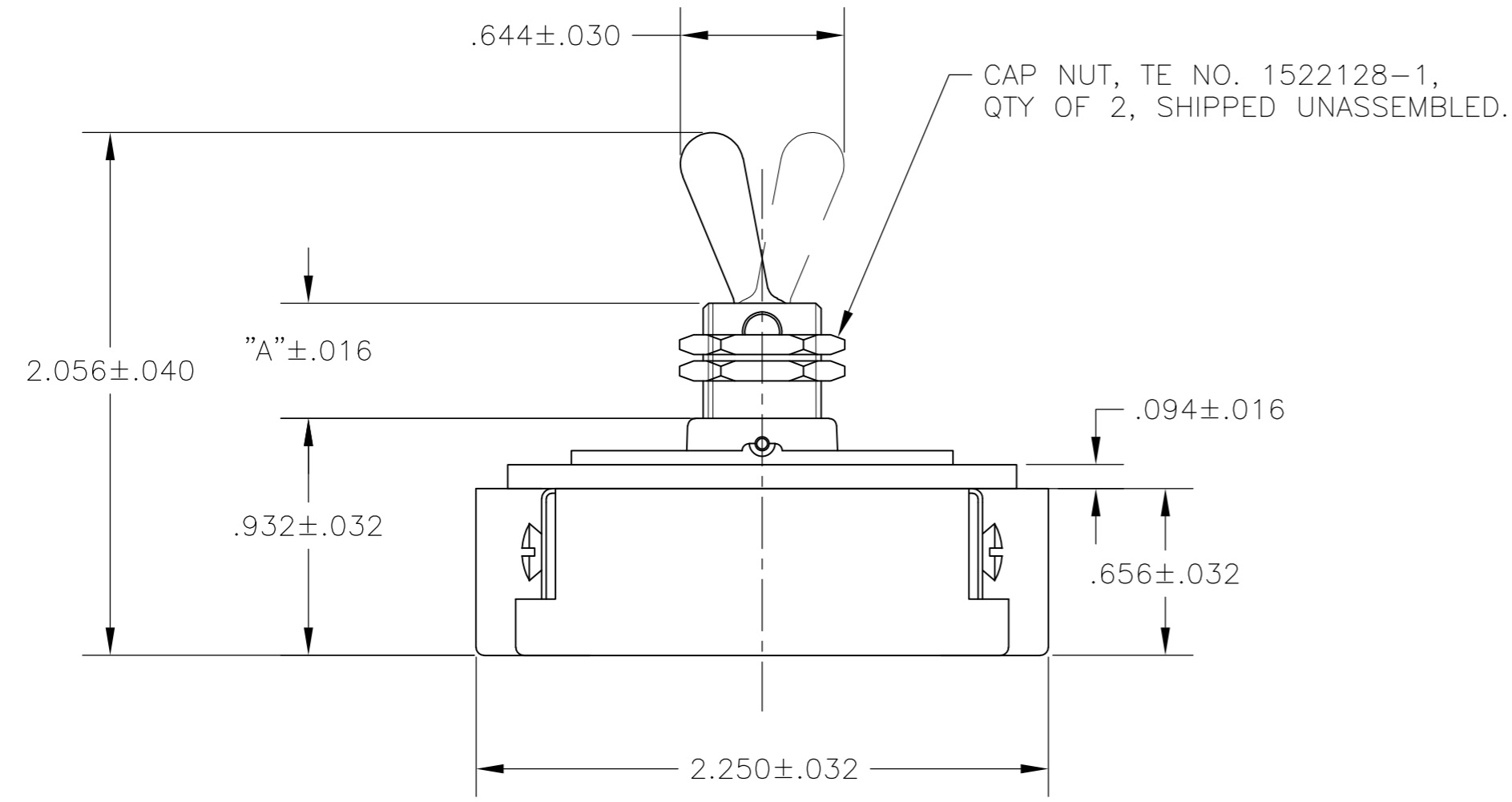

6-32 X .250 LONG UNDERCUT BDG. HD. SCREW, PART NO. 1523927-1. SWITCHES 1520228-1, 1520228-2, 1520228-3, 1-1520228-1, 2-1520228-3, 2-1520228-4, 6520228-1, 6520228-2, 6520228-3, 1-6520228-1, 2-6520228-3, 2-6520228-4: QTY OF 4, SHIPPED UNASSEMBLED. SWITCH 1-1520228-0, 1-6520228-0 ONLY: QTY OF 4, SHIPPED ASSEMBLED.

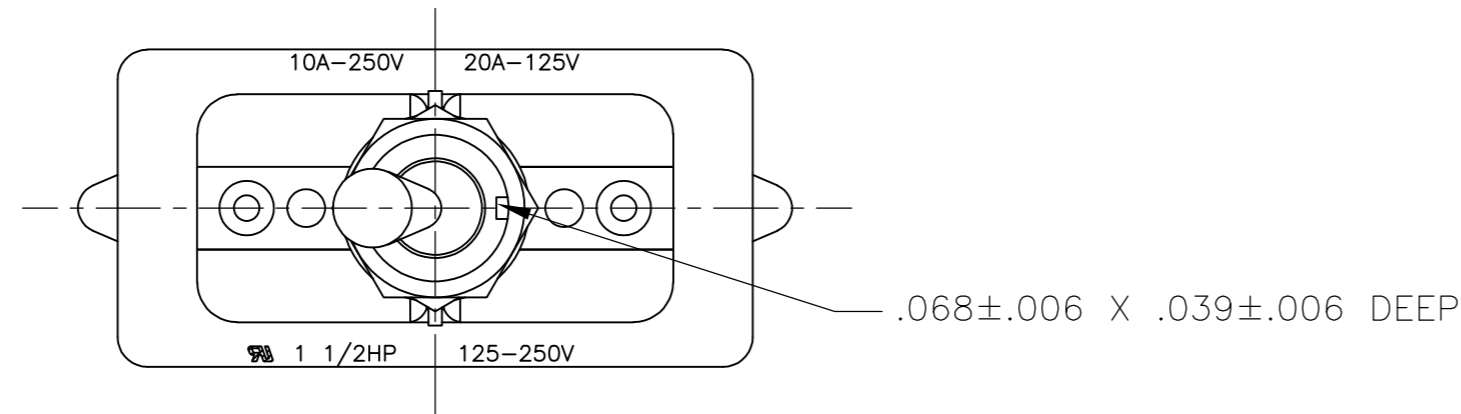
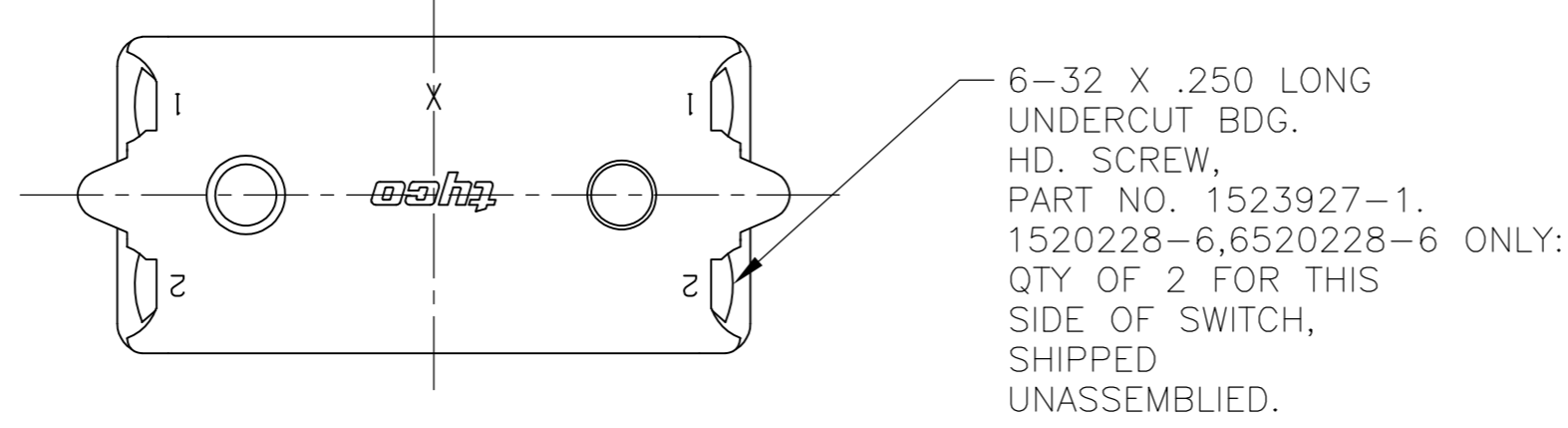
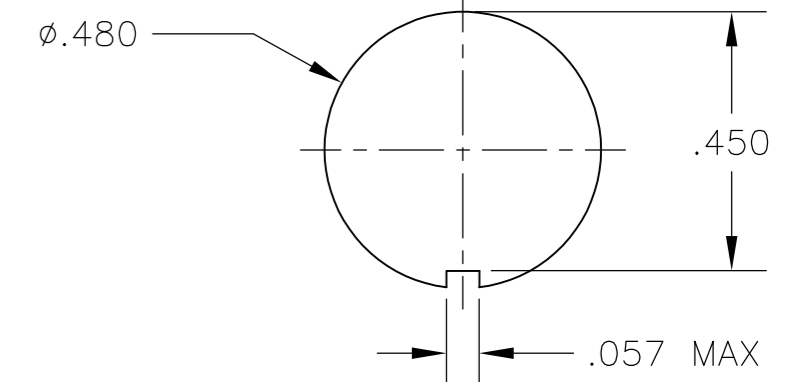
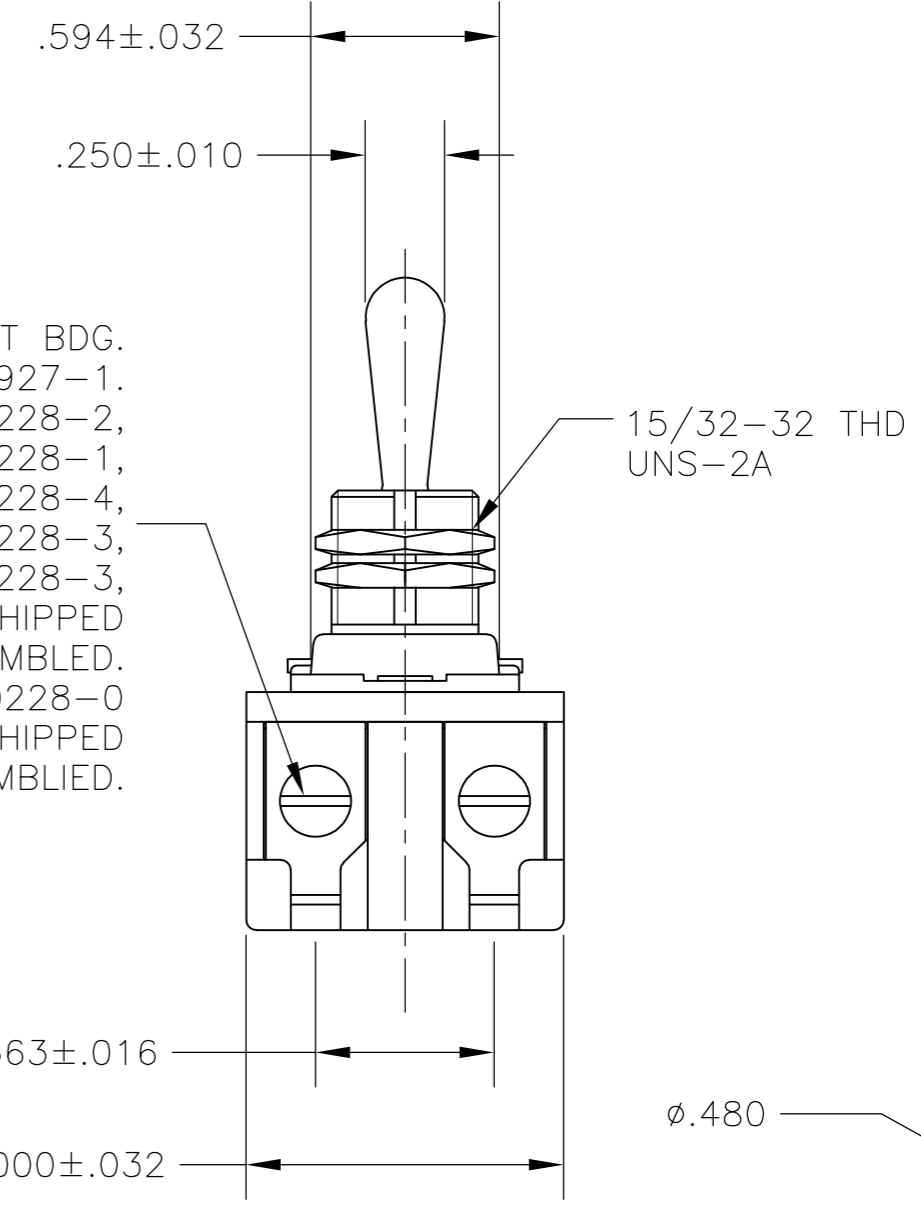

- 1 T-PAK - SWITCH AND HARDWARE INDIVIDUALLY PACKED IN PLASTIC BAGS BEFORE BEING PLACED IN A INTERMEDIATE BOX WHICH IS THEN PLACED IN A SHIPPING BOX. SEE TABLE.
- 2 P/N X-6520228-X IS ROHS COMPLIANT.
- 3 MOUNTING DIMENSIONS FOR REFERENCE ONLY.

2-1520228-4/2-6520228-4	7360K8 T-PAK	15/32" THD LENGTH DIE CAST	.469	DPST
2-1520228-3/2-6520228-3	7360K7 T-PAK	11/32" THD LENGTH DIE CAST	.344	DPST
1-1520228-1/1-6520228-1	8910K219	15/32" THD LENGTH DIE CAST	.469	DPST
1-1520228-0/1-6520228-0	8910K205	11/32" THD LENGTH DIE CAST	.344	DPST
1520228-6/6520228-6	7362K4	15/32" THD LENGTH DIE CAST	.469	SPST WITH BUSSING
1520228-3/6520228-3	7360K7	11/32" THD LENGTH DIE CAST	.344	DPST
1520228-2/6520228-2	7359K3	15/32" THD LENGTH DIE CAST	.469	DPST
1520228-1/6520228-1	7359K2	11/32" THD LENGTH DIE CAST	.344	DPST
PART NO.	ARAB NO.	BUSHING / PLATE ASSY	A	DESCRIPTION

90-345

THIS DRAWING IS A CONTROLLED DOCUMENT.		DWN	26SEP02	<b>TE</b> TE Connectivity	
DIMENSIONS: INCHES		CHK	-		
TOLERANCES UNLESS OTHERWISE SPECIFIED:		APVD	-	NAME	
0 PLC	± -	PRODUCT SPEC		20 AMP 125V AC/DC, 10 AMP 250V AC/DC, 1 1/2 HP 125V/250V AC/DC, ONE HOLE MOUNTING TOOL HANDLE TOGGLE SWITCH	
1 PLC	± -	APPLICATION SPEC		SIZE	A2
2 PLC	± -	WEIGHT		CAGE CODE	00779
3 PLC	± -	CUSTOMER DRAWING		DRAWING NO	1520228
4 PLC	± -	SCALE		RESTRICTED TO	-
ANGLES	± -	SHEET		1 of 4	
FINISH	-	REV		B2	

THIS DRAWING IS UNPUBLISHED. RELEASED FOR PUBLICATION  
 © COPYRIGHT - By - ALL RIGHTS RESERVED.

LOC	DIST	REVISIONS			
P	LTR	DESCRIPTION	DATE	DWN	APVD
AD	00	SEE SHEET 1	-	-	-

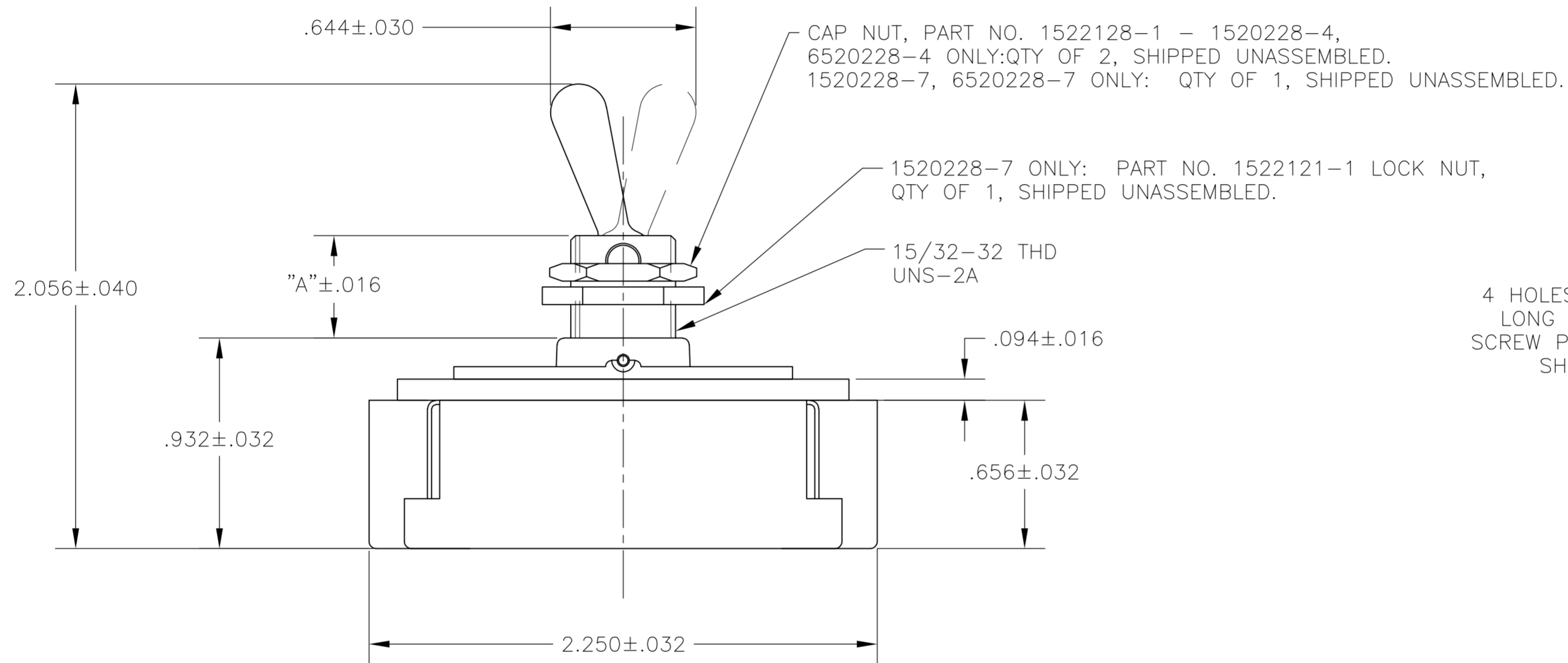
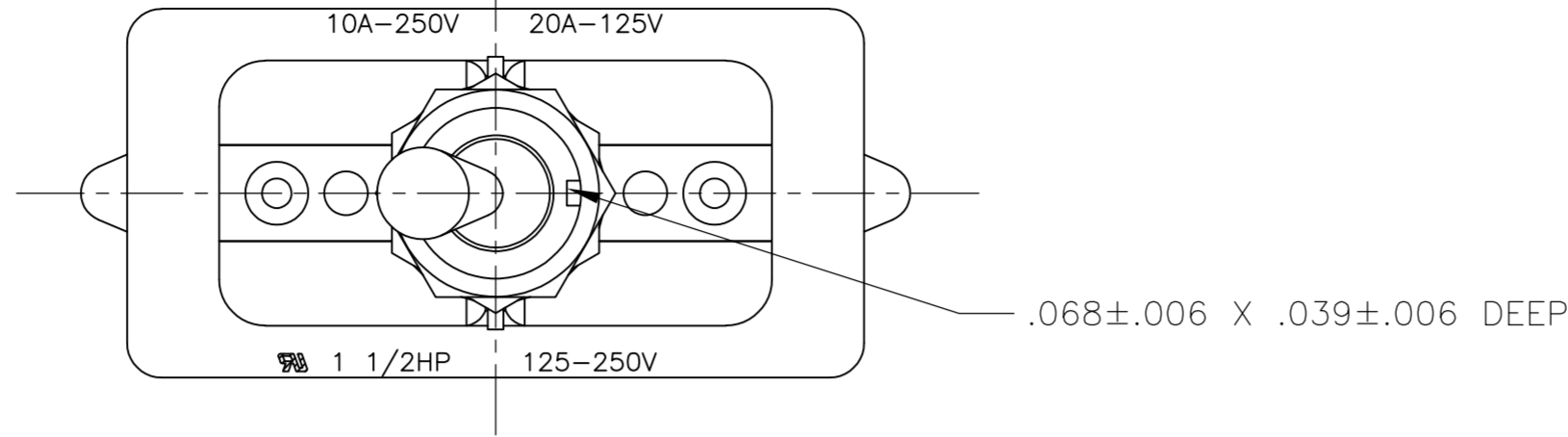

4 HOLES FOR 6-32 X .250  
 LONG UNDERCUT BDG. HD.  
 SCREW PART NO. 1523927-1  
 SHIPPED UNASSEMBLED

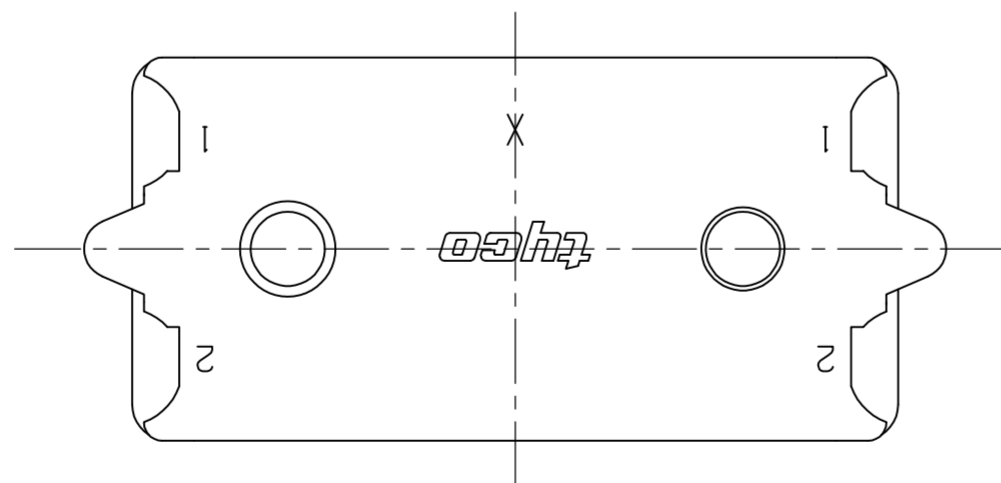
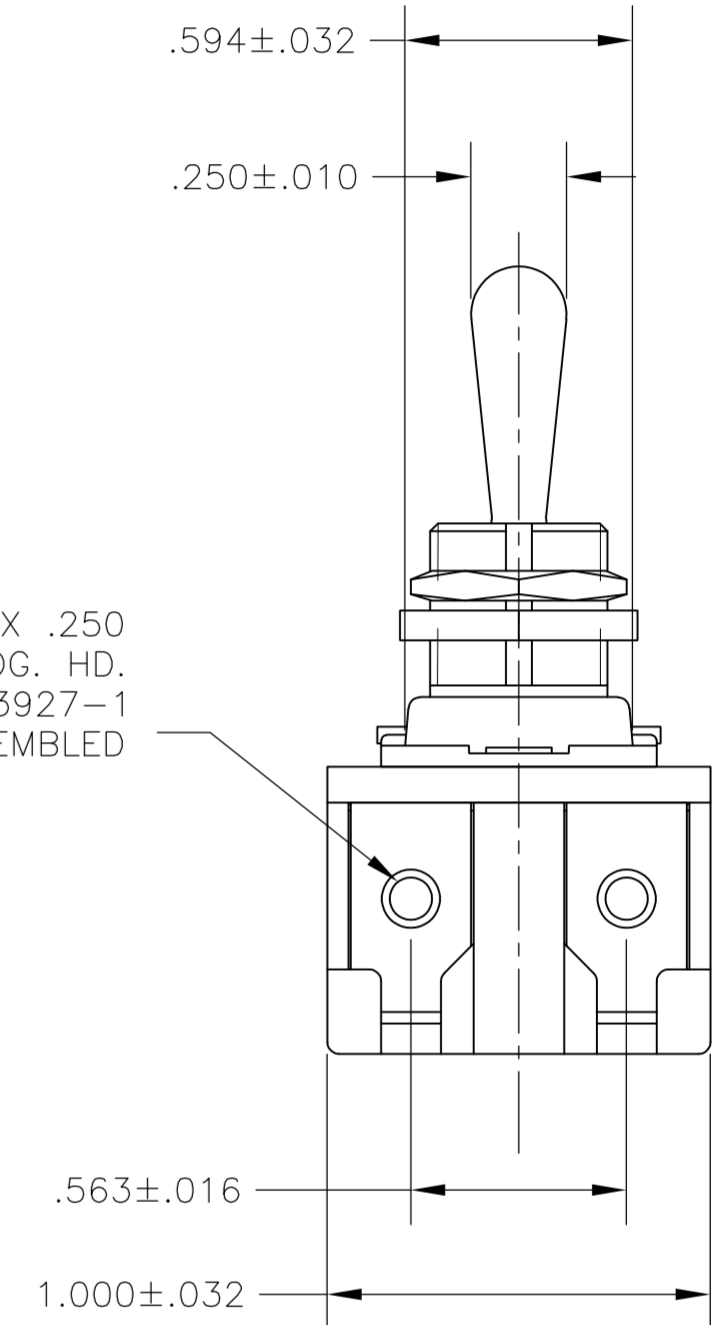

- 1 T-PAK - SWITCH AND HARDWARE INDIVIDUALLY PACKED IN PLASTIC BAGS BEFORE BEING PLACED IN AN INTERMEDIATE BOX WHICH IS THEN PLACED IN A SHIPPING BOX. SEE TABLE.
- 2 P/N X-6520228-X IS ROHS COMPLIANT.
- 3 MOUNTING DIMENSIONS FOR REFERENCE ONLY.

91-399

PART NO.	ARAB NO.	BUSHING / PLATE ASSY	A	DESCRIPTION
1520228-7/6520228-7	8909K23	15/32" THD LENGTH DIE CAST	.469	DPST T-PAKED W/SPECIAL HARDWARE
1520228-4/6520228-4	7360K8	15/32" THD LENGTH DIE CAST	.469	DPST

THIS DRAWING IS A CONTROLLED DOCUMENT.		DWN W. HANSON 29APR93	<b>STE</b> TE Connectivity	
DIMENSIONS: INCHES		CHK W. Leonard 02MAY93		
TOLERANCES UNLESS OTHERWISE SPECIFIED:		APVD E. WESOLEK 03MAY93	NAME 20 AMP 125V AC/DC, 10 AMP 250V AC/DC, 1 1/2 HP 125V/250V AC/DC, ONE HOLE MOUNTING TOOL HANDLE TOGGLE SWITCH	
MATERIAL		FINISH	SIZE A2	CAGE CODE 00779
MATERIAL		FINISH	DRAWING NO C=1520228	
MATERIAL		FINISH	RESTRICTED TO	
MATERIAL		FINISH	SCALE 2:1	SHEET 2 of 4
MATERIAL		FINISH	REV B2	
MATERIAL		FINISH	CUSTOMER DRAWING	

THIS DRAWING IS UNPUBLISHED. RELEASED FOR PUBLICATION  
 © COPYRIGHT - By - ALL RIGHTS RESERVED.

LOC	DIST	REVISIONS			
P	LTR	DESCRIPTION	DATE	DWN	APVD
AD	00	SEE SHEET 1	-	-	-

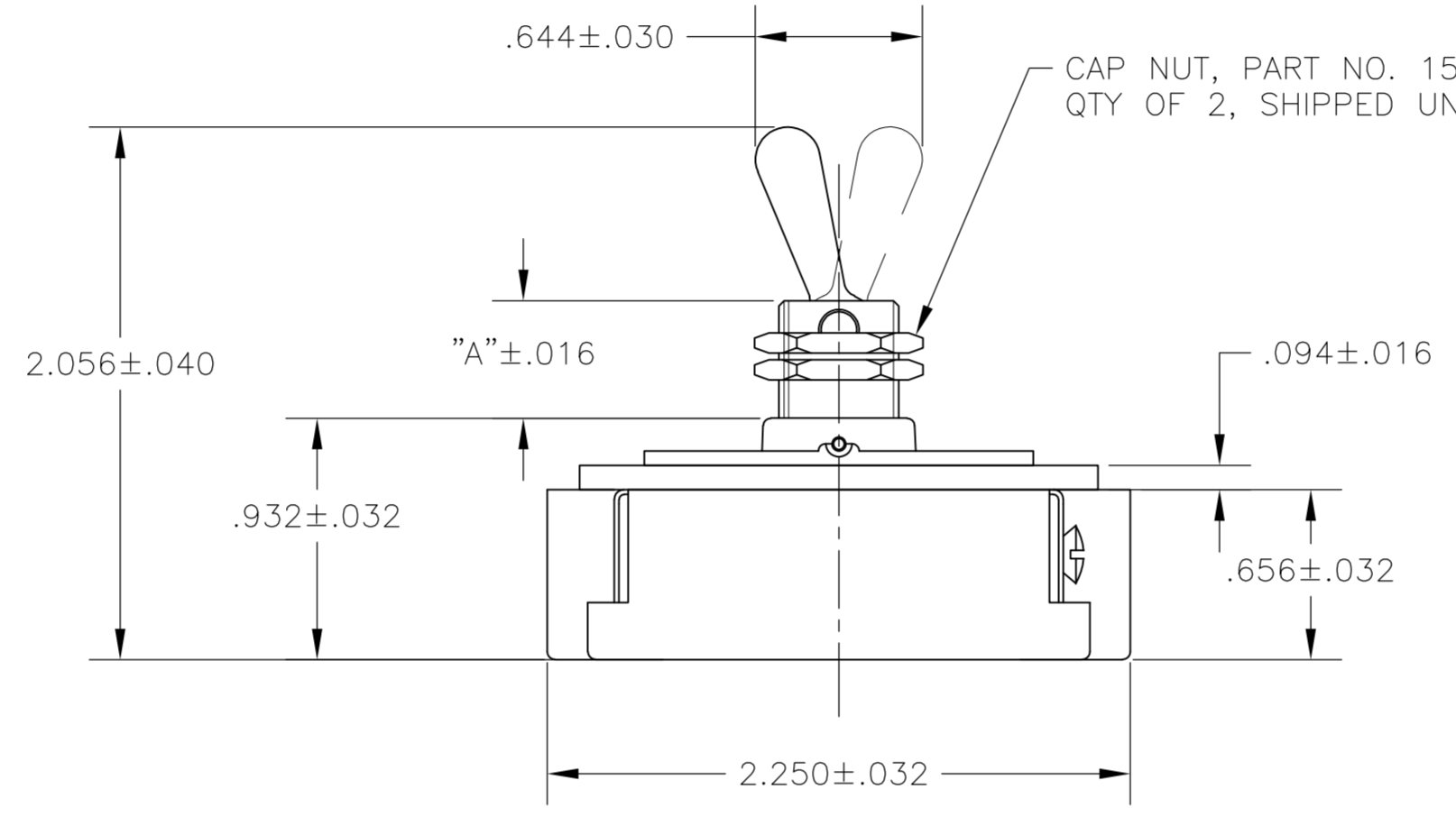
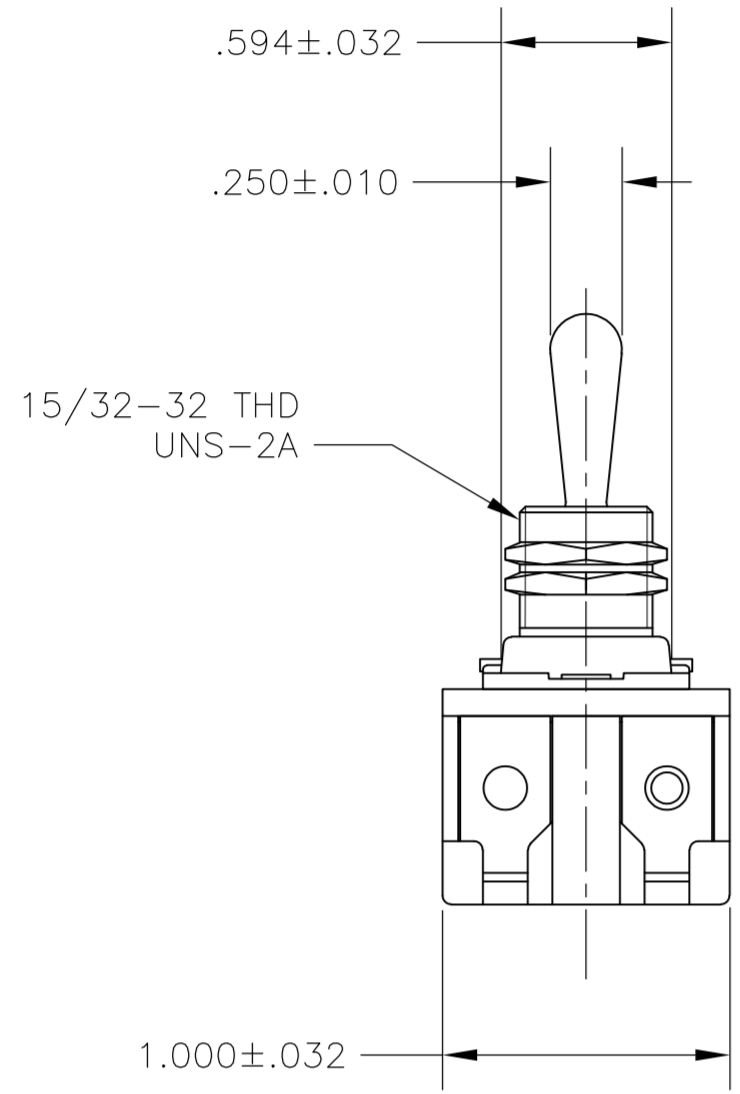
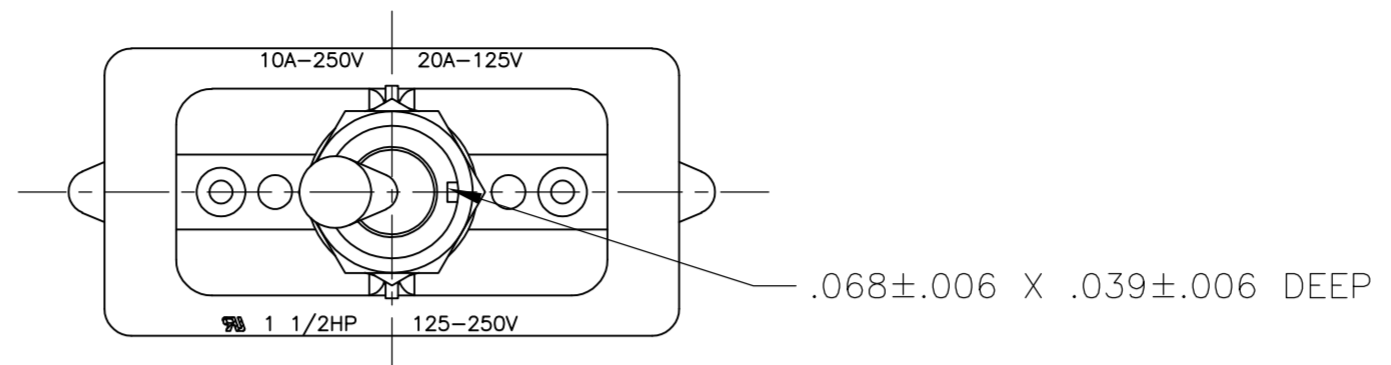

6-32 X .250 LONG UNDERCUT BDG. HD. SCREW, PART NO. 1523927-1. QTY OF 2 APPLIED THIS END ONLY, SHIPPED UNASSEMBLED.

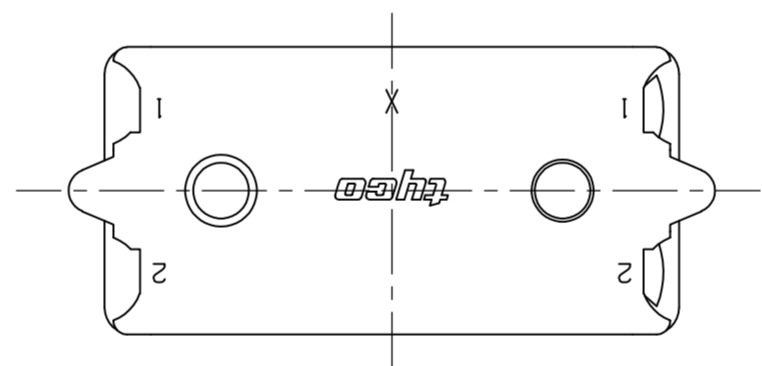
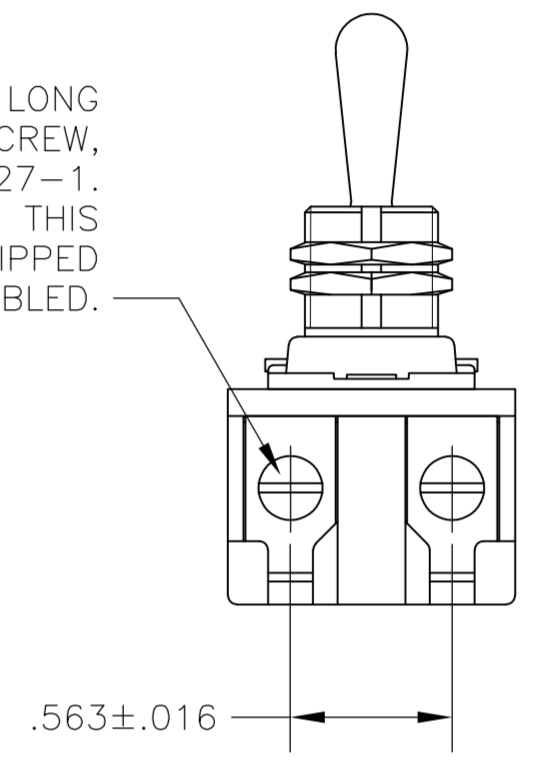

- 1 T-PAK - SWITCH AND HARDWARE INDIVIDUALLY PACKED IN PLASTIC BAGS BEFORE BEING PLACED IN A INTERMEDIATE BOX WHICH IS THEN PLACED IN A SHIPPING BOX. SEE TABLE.
- 2 PLY-0-PAK - SWITCH AND HARDWARE INDIVIDUALLY PACKED IN PLASTIC BAGS BEFORE BEING PACKED LOOSE IN A SHIPPING BOX. SEE TABLE.
- 3 P/N X-6520228-X IS ROHS COMPLIANT.
- 4 MOUNTING DIMENSIONS FOR REFERENCE ONLY.

PART NO.	ARAB NO.	BUSHING / PLATE ASSY	A	DESCRIPTION	
2-1520228-5/2-6520228-5	7361K5	T-PAK	15/32" THD LENGTH DIE CAST	.469	SPST
1520228-9/6520228-9	8910K191		15/32" THD LENGTH DIE CAST	.469	SPST (PLY-0-PAK)
1520228-5/6520228-5	7361K5		15/32" THD LENGTH DIE CAST	.469	SPST

THIS DRAWING IS A CONTROLLED DOCUMENT.

DWN	J. SMITH	13DEC77
CHK	R. GLENN	13DEC77
APVD	M.R. DUMMER	13DEC77

TE Connectivity

NAME: 20 AMP 125V AC/DC, 10 AMP 250V AC/DC, 1 1/2 HP 125V/250V AC/DC, ONE HOLE MOUNTING TOOL HANDLE TOGGLE SWITCH

SIZE	A2	CAGE CODE	00779	DRAWING NO	C=1520228	RESTRICTED TO	-
CUSTOMER DRAWING	SCALE	NTS	SHEET	3 of 4	REV	B2	

THIS DRAWING IS UNPUBLISHED. RELEASED FOR PUBLICATION  
 © COPYRIGHT - By - ALL RIGHTS RESERVED.

LOC	DIST	REVISIONS			
P	LTR	DESCRIPTION	DATE	DWN	APVD
AD	00	SEE SHEET 1	-	-	-

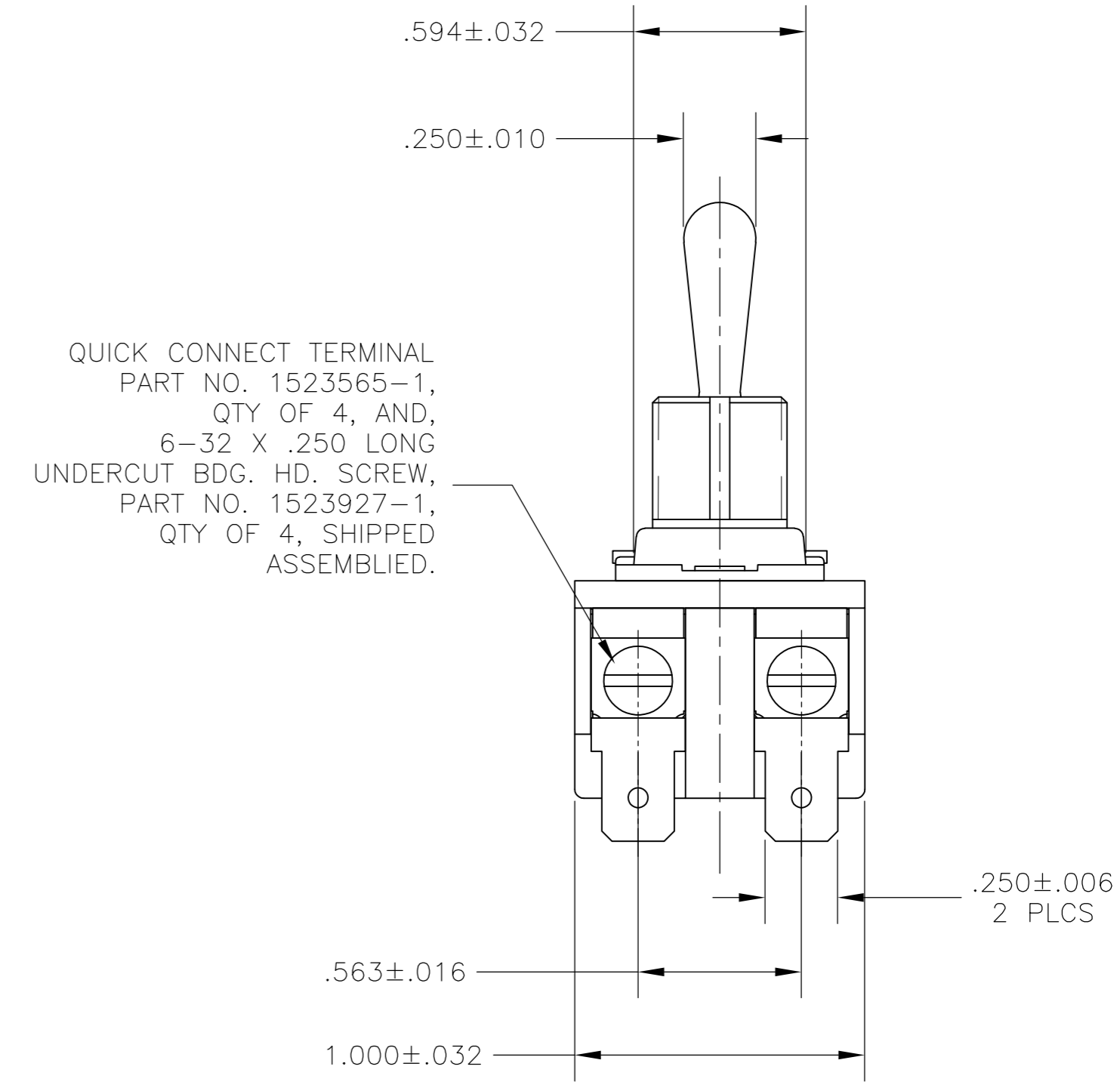
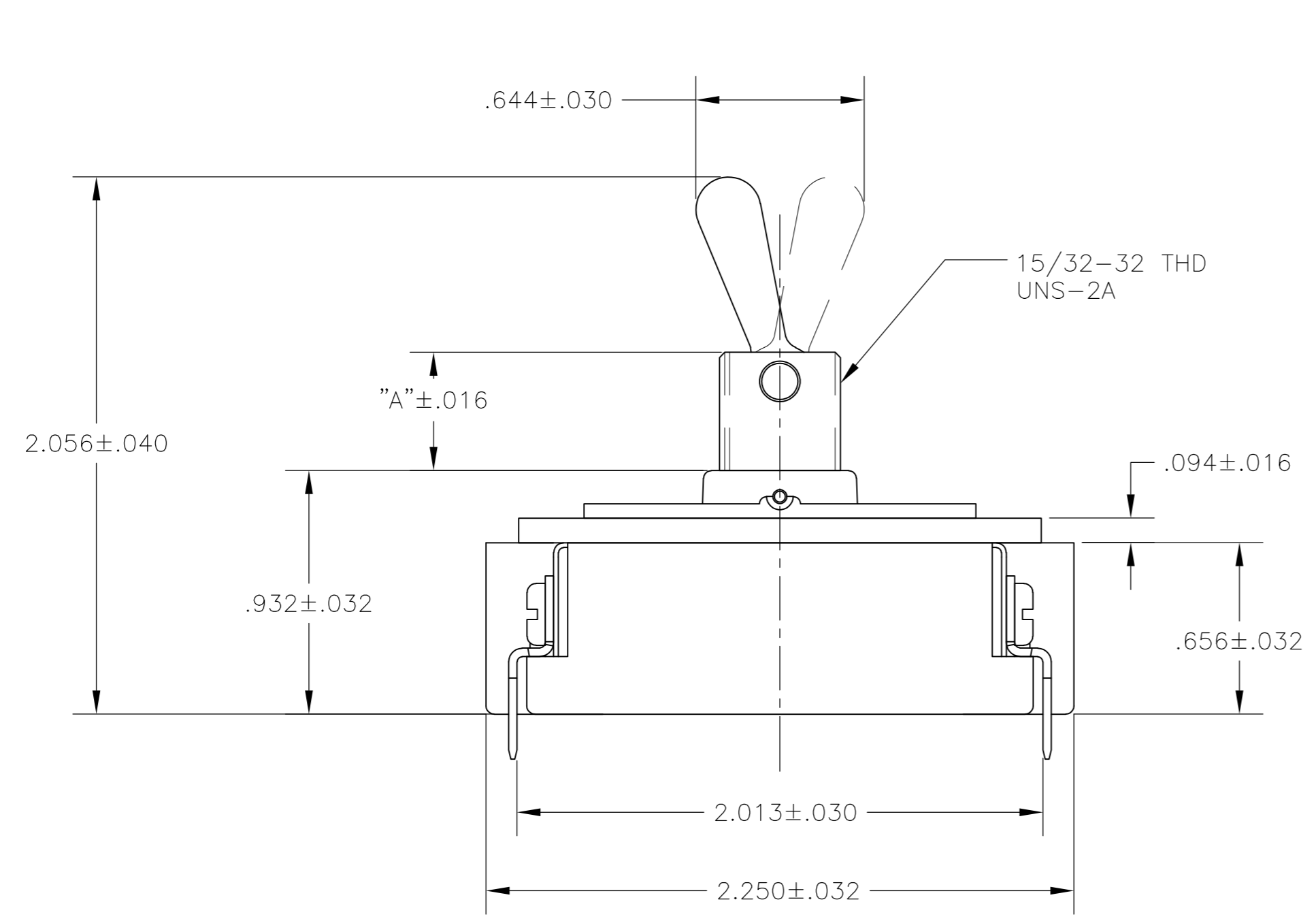
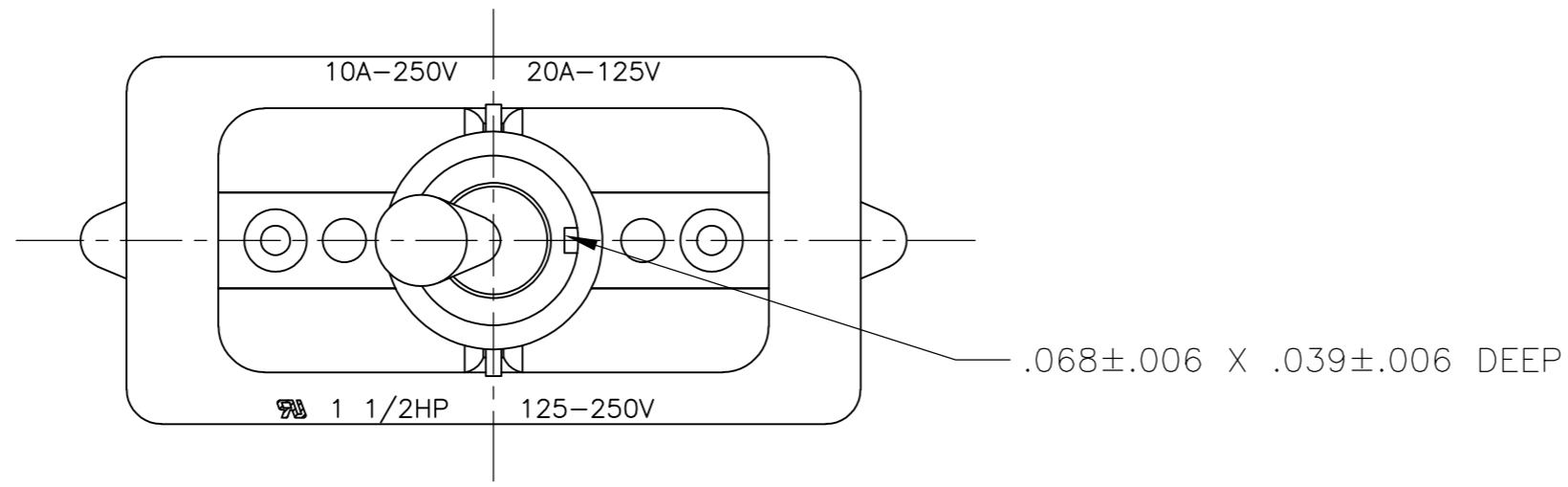

- 1 P/N X-6520228-X IS ROHS COMPLIANT.
- 2 MOUNTING DIMENSIONS FOR REFERENCE ONLY.

91-601

PART NO.	ARAB NO.	BUSHING / PLATE ASSY	A	DESCRIPTION
1520228-8/6520228-8	8910K12	15/32" THD LENGTH DIE CAST	.469	DPST

THIS DRAWING IS A CONTROLLED DOCUMENT.		DWN T.CHRISTENSEN 25OCT95	<b>TE</b> TE Connectivity	
DIMENSIONS: INCHES		CHK W.HANSON 01NOV95		
TOLERANCES UNLESS OTHERWISE SPECIFIED:		APVD M.R.DUMMER 09NOV95	NAME 20 AMP 125V AC/DC, 10 AMP 250V AC/DC, 1 1/2 HP 125V/250V AC/DC, ONE HOLE MOUNTING TOOL HANDLE TOGGLE SWITCH	
0 PLC ± -		PRODUCT SPEC -	SIZE A2	CAGE CODE 00779
1 PLC ± -		APPLICATION SPEC -	DRAWING NO C=1520228	RESTRICTED TO -
2 PLC ± -		WEIGHT -	SCALE 2:1	SHEET 4 of 4
3 PLC ± -		MATERIAL -	REV B2	
4 PLC ± -		FINISH -		
ANGLES ± -		CUSTOMER DRAWING		