

FEATURES

- Low on resistance (300 Ω typical)
- Fast switching times
 - t_{ON} : 250 ns maximum
 - t_{OFF} : 250 ns maximum
- Low power dissipation (3.3 mW maximum)
- Fault and overvoltage protection (-40 V to $+55$ V)
- All switches off with power supply off
- Analog output of on channel clamped within power supplies if an overvoltage occurs
- Latch-up proof construction
- Break-before-make construction
- TTL and CMOS compatible inputs

APPLICATIONS

- Existing multiplexer applications (both fault-protected and nonfault-protected)
- New designs requiring multiplexer functions

GENERAL DESCRIPTION

The ADG528F¹ is a CMOS analog multiplexer, with the comprising eight single channels. This multiplexer provides fault protection. Using a series n-channel, p-channel, n-channel MOSFET structure, both device and signal source protection is provided in the event of an overvoltage or power loss. The multiplexer can withstand continuous overvoltage inputs from -40 V to $+55$ V. During fault conditions, the multiplexer input (or output) appears as an open circuit and only a few nanoamperes of leakage current will flow. This protects not only the multiplexer and the circuitry driven by the multiplexer, but also protects the sensors or signal sources that drive the multiplexer.

The ADG528F switches one of eight inputs to a common output as determined by the 3-bit binary address lines A0, A1, and A2. The ADG528F has on-chip address and control latches that facilitate microprocessor interfacing. An EN input on the device is used to enable or disable the device. When disabled, all channels are switched off.

FUNCTIONAL BLOCK DIAGRAM

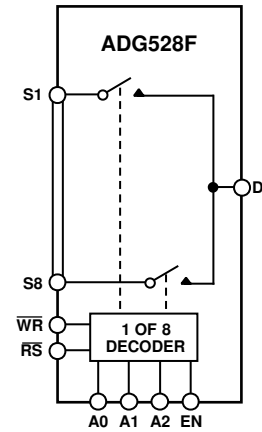

Figure 1.

PRODUCT HIGHLIGHTS

1. Fault protection.
The ADG528F can withstand continuous voltage inputs from -40 V to $+55$ V. When a fault occurs due to the power supplies being turned off, all the channels are turned off and only a leakage current of a few nanoamperes flows.
2. On channel turns off while fault exists.
3. Low R_{ON} .
4. Fast switching times.
5. Break-before-make switching.
Switches are guaranteed break-before-make so that input signals are protected against momentary shorting.
6. Trench isolation eliminates latch-up.
A dielectric trench separates the p-channel and n-channel MOSFETs thereby preventing latch-up.

Rev. F

Information furnished by Analog Devices is believed to be accurate and reliable. However, no responsibility is assumed by Analog Devices for its use, nor for any infringements of patents or other rights of third parties that may result from its use. Specifications subject to change without notice. No license is granted by implication or otherwise under any patent or patent rights of Analog Devices. Trademarks and registered trademarks are the property of their respective owners.

TABLE OF CONTENTS

Features	1	Absolute Maximum Ratings	6
Applications.....	1	ESD Caution.....	6
Functional Block Diagram	1	Pin Configuration and Function Descriptions.....	7
General Description	1	Typical Performance Characteristics	8
Product Highlights	1	Terminology	10
Revision History	2	Theory of Operation	11
Specifications.....	3	Test Circuits.....	12
Dual Supply	3	Outline Dimensions	15
Truth Table	4	Ordering Guide	15
Timing Diagrams.....	5		

REVISION HISTORY

7/11—Rev. E to Rev. F

Deleted ADG508F/ADG509F	Universal
Changes to Table 3.....	6
Added Table 4.....	7
Updated Outline Dimensions	15
Changes to Ordering Guide	15

7/09—Rev. D to Rev. E

Updated Format	Universal
Added TSSOP	Universal
Updated Outline Dimensions	15
Changes to Ordering Guide	18

4/01—Data Sheet Changed from Rev. C to Rev. D.

Changes to Ordering Guide	1
Changes to Specifications Table.....	2
Max Ratings Changed	4
Deleted 16-Lead Cerdip from Outline Dimensions	11
Deleted 18-Lead Cerdip from Outline Dimensions	12

SPECIFICATIONS

DUAL SUPPLY

$V_{DD} = +15\text{ V} \pm 10\%$, $V_{SS} = -15\text{ V} \pm 10\%$, $GND = 0\text{ V}$, unless otherwise noted.

Table 1.

Parameter	B Version		Unit	Test Conditions/Comments
	+25°C	-40°C to +85°C		
ANALOG SWITCH				
Analog Signal Range		$V_{SS} + 3$ $V_{DD} - 1.5$	V min V max	
R_{ON}	300	350	Ω typ	$-10\text{ V} \leq V_S \leq +10\text{ V}$, $I_S = 1\text{ mA}$; $V_{DD} = +15\text{ V} \pm 10\%$, $V_{SS} = -15\text{ V} \pm 10\%$
		400	Ω max	$-10\text{ V} \leq V_S \leq +10\text{ V}$, $I_S = 1\text{ mA}$; $V_{DD} = +15\text{ V} \pm 5\%$, $V_{SS} = -15\text{ V} \pm 5\%$
R_{ON} Drift	0.6		%/°C typ	$V_S = 0\text{ V}$, $I_S = 1\text{ mA}$
R_{ON} Match	5		% max	$V_S = 0\text{ V}$, $I_S = 1\text{ mA}$
LEAKAGE CURRENTS				
Source Off Leakage I_S (Off)	± 0.02 ± 1	± 50	nA typ nA max	$V_D = \pm 10\text{ V}$, $V_S = \mp 10\text{ V}$; See Figure 19
Drain Off Leakage I_D (Off)	± 0.04 ± 1	± 60	nA typ nA max	$V_D = \pm 10\text{ V}$, $V_S = \mp 10\text{ V}$; See Figure 20
Channel On Leakage I_D , I_S (On)	± 0.04 ± 1	± 60	nA typ nA max	$V_S = V_D = \pm 10\text{ V}$; See Figure 21
FAULT				
Output Leakage Current (With Overvoltage)	± 0.02 ± 2	± 2	nA typ μA max	$V_S = \pm 33\text{ V}$, $V_D = 0\text{ V}$, see Figure 20
Input Leakage Current (With Overvoltage)	± 0.005 ± 2		μA typ μA max	$V_S = \pm 25\text{ V}$, $V_D = \mp 10\text{ V}$, see Figure 22
Input Leakage Current (With Power Supplies Off)	± 0.001 ± 2		μA typ μA max	$V_S = \pm 25\text{ V}$, $V_D = V_{EN} = A0, A1, A2 = 0\text{ V}$ See Figure 23
DIGITAL INPUTS				
Input High Voltage, V_{INH}		2.4	V min	
Input Low Voltage, V_{INL}		0.8	V max	
Input Current, I_{INL} or I_{INH}		± 1	μA max	$V_{IN} = 0$ or V_{DD}
C_{IN} , Digital Input Capacitance	5		pF typ	
DYNAMIC CHARACTERISTICS¹				
$t_{TRANSITION}$	200 300	400	ns typ ns max	$R_L = 1\text{ M}\Omega$, $C_L = 35\text{ pF}$; $V_{S1} = \pm 10\text{ V}$, $V_{S8} = \mp 10\text{ V}$; see Figure 24
t_{OPEN}	50 25	10	ns typ ns min	$R_L = 1\text{ k}\Omega$, $C_L = 35\text{ pF}$; $V_S = 5\text{ V}$; see Figure 25
t_{ON} (EN, \overline{WR})	200 250	400	ns typ ns max	$R_L = 1\text{ k}\Omega$, $C_L = 35\text{ pF}$; $V_S = 5\text{ V}$; see Figure 26
t_{OFF} (EN, \overline{RS})	200		ns typ	$R_L = 1\text{ k}\Omega$, $C_L = 35\text{ pF}$;
t_{SETT} , Settling Time	250	400	ns max	$V_S = 5\text{ V}$; see Figure 26
0.1%		1	μs typ	$R_L = 1\text{ k}\Omega$, $C_L = 35\text{ pF}$;
0.01%		2.5	μs typ	$V_S = 5\text{ V}$
t_W , Write Pulse Width	100	120	ns min	
t_S , Address, Enable Setup Time		100	ns min	
t_H , Address, Enable Hold Time		10	ns min	
t_{RS} , Reset Pulse Width		100	ns min	

ADG528F

Parameter	B Version		Unit	Test Conditions/Comments
	+25°C	-40°C to +85°C		
Charge Injection	4		pC typ	$V_S = 0\text{ V}$, $R_S = 0\ \Omega$, $C_L = 1\ \text{nF}$; see Figure 29 $R_L = 1\ \text{k}\Omega$, $C_L = 15\ \text{pF}$, $f = 100\ \text{kHz}$; $V_S = 7\ \text{V rms}$; see Figure 30
Off Isolation	68		dB typ	
	50		dB min	
C_S (Off)	5		pF typ	
C_D (Off)	50		pF typ	
POWER REQUIREMENTS				
I_{DD}	0.1	0.2	mA max	$V_{IN} = 0\ \text{V}$ or $5\ \text{V}$
I_{SS}	0.1	0.1	mA max	

¹ Guaranteed by design, not subject to production test.

TRUTH TABLE

Table 2. ADG528F Truth Table¹

A2	A1	A0	EN	WR	RS	On Switch
X	X	X	X	\downarrow	1	Retains previous switch condition
X	X	X	X	X	0	None (address and enable latches cleared)
X	X	X	0	0	1	None
0	0	0	1	0	1	1
0	0	1	1	0	1	2
0	1	0	1	0	1	3
0	1	1	1	0	1	4
1	0	0	1	0	1	5
1	0	1	1	0	1	6
1	1	0	1	0	1	7
1	1	1	1	0	1	8

¹ X = don't care.

TIMING DIAGRAMS

Figure 2 shows the timing sequence for latching the switch address and enable inputs. The latches are level sensitive; therefore, while \overline{WR} is held low, the latches are transparent and the switches respond to the address and enable inputs.

This input data is latched on the rising edge of \overline{WR} . Figure 3 shows the reset pulse width, t_{RS} , and the reset turnoff time, t_{OFF} (\overline{RS}). Note that all digital input signals rise and fall times are measured from 10% to 90% of 3 V. $t_R = t_F = 20$ ns.

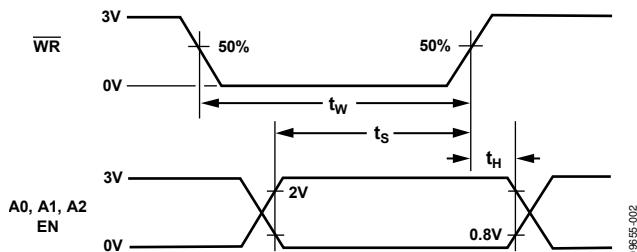

Figure 2. Timing Sequence for Latching the Switch Address and Enable Inputs

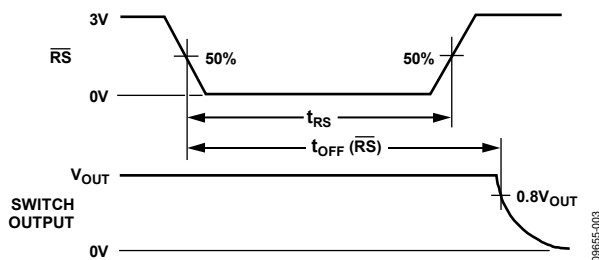

Figure 3. Reset Pulse Width

ABSOLUTE MAXIMUM RATINGS

T_A = 25°C unless otherwise noted.

Table 3.

Parameter	Rating
V _{DD} to V _{SS}	44 V
V _{DD} to GND	−0.3 V to +25 V
V _{SS} to GND	+0.3 V to −25 V
Digital Input, EN, Ax	−0.3 V to V _{DD} + 2 V or 20 mA, whichever occurs first
V _S , Analog Input Overvoltage with Power On (V _{DD} = +15 V, V _{SS} = −15 V)	V _{SS} − 25 V to V _{DD} + 40 V
V _S , Analog Input Overvoltage with Power Off (V _{DD} = 0 V, V _{SS} = 0 V)	−40 V to +55 V
Continuous Current, S or D	20 mA
Peak Current, S or D (Pulsed at 1 ms, 10% Duty Cycle Max)	40 mA
Operating Temperature Range Industrial (B Version)	−40°C to +85°C
Storage Temperature Range	−65°C to +150°C
Junction Temperature	150°C
θ _{JA} , Thermal Impedance	90°C/W
Lead Temperature, Soldering Vapor Phase (60 sec)	215°C
Infrared (15 sec)	220°C

Stresses above those listed under Absolute Maximum Ratings may cause permanent damage to the device. This is a stress rating only; functional operation of the device at these or any other conditions above those indicated in the operational section of this specification is not implied. Exposure to absolute maximum rating conditions for extended periods may affect device reliability.

ESD CAUTION



ESD (electrostatic discharge) sensitive device. Charged devices and circuit boards can discharge without detection. Although this product features patented or proprietary protection circuitry, damage may occur on devices subjected to high energy ESD. Therefore, proper ESD precautions should be taken to avoid performance degradation or loss of functionality.

PIN CONFIGURATION AND FUNCTION DESCRIPTIONS

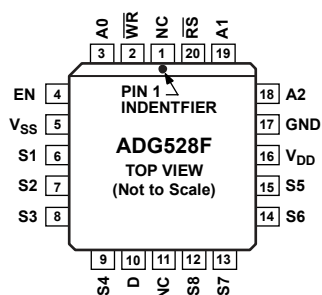

NC = NO CONNECT. DO NOT CONNECT TO THIS PIN.

Figure 4. Pin Configuration

09655F-007

Table 4. Pin Function Descriptions

Pin No.	Mnemonic	Description
1	NC	No Connect. This pin is open.
2	$\overline{\text{WR}}$	Write. The $\overline{\text{WR}}$ signal latches the state of the address control lines and the enable line.
3	A0	Logic Control Input.
4	EN	Active High Digital Input. When low, the device is disabled and all switches are off. When high, Ax logic inputs determine on switches.
5	V _{SS}	Most Negative Power Supply Potential. In single-supply applications, this pin can be connected to ground.
6	S1	Source Terminal 1. This pin can be an input or an output.
7	S2	Source Terminal 2. This pin can be an input or an output.
8	S3	Source Terminal 3. This pin can be an input or an output.
9	S4	Source Terminal 4. This pin can be an input or an output.
10	D	Drain Terminal. This pin can be an input or an output.
11	NC	No Connect. This pin is open.
12	S8	Source Terminal 8. This pin can be an input or an output.
13	S7	Source Terminal 7. This pin can be an input or an output.
14	S6	Source Terminal 6. This pin can be an input or an output.
15	S5	Source Terminal 5. This pin can be an input or an output.
16	V _{DD}	Most Positive Power Supply Potential.
17	GND	Ground (0 V) Reference.
18	A2	Logic Control Input.
19	A1	Logic Control Input.
20	$\overline{\text{RS}}$	Reset. The $\overline{\text{RS}}$ signal clears both the address and enable data in the latches resulting in no output (all switches off).

TYPICAL PERFORMANCE CHARACTERISTICS

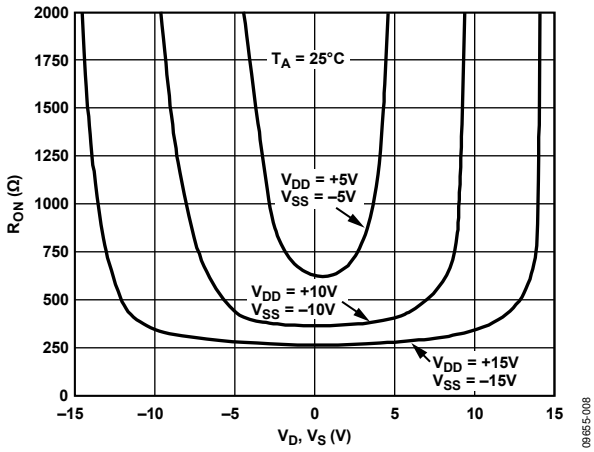

Figure 5. On Resistance as a Function of V_D (V_S)

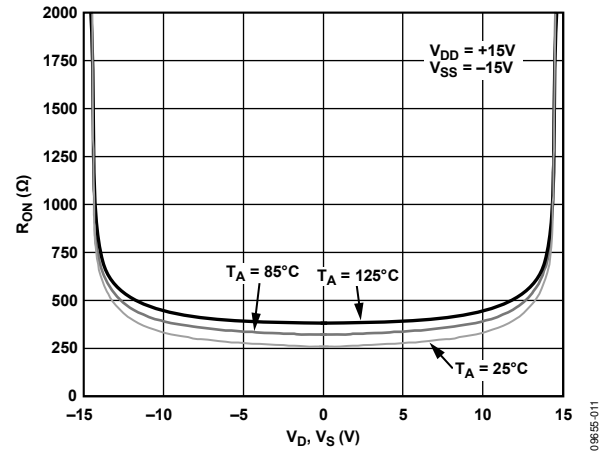

Figure 8. On Resistance as a Function of V_D (V_S) for Different Temperatures

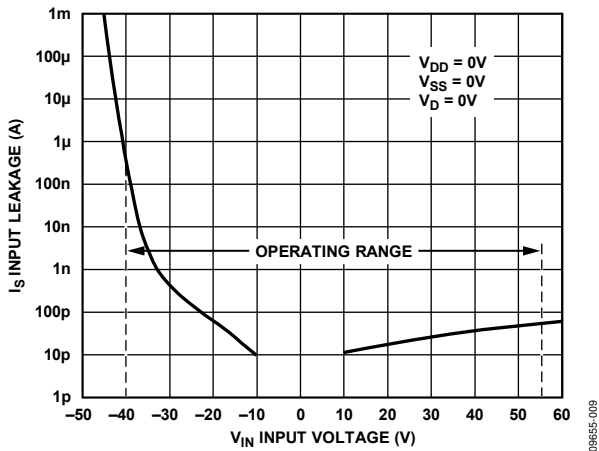

Figure 6. Input Leakage Current as a Function of V_S (Power Supplies Off) During Overvoltage Conditions

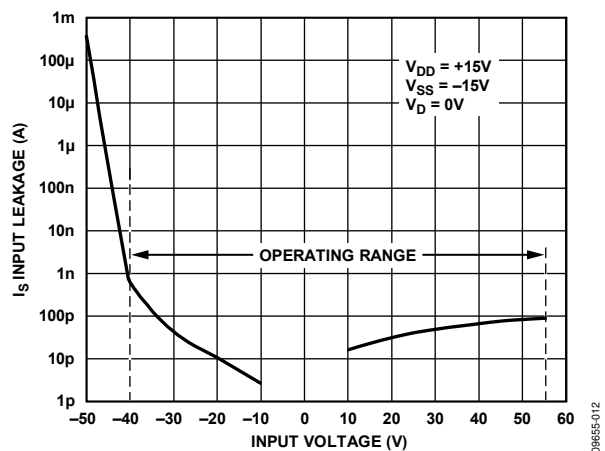

Figure 9. Input Leakage Current as a Function of V_S (Power Supplies On) During Overvoltage Conditions

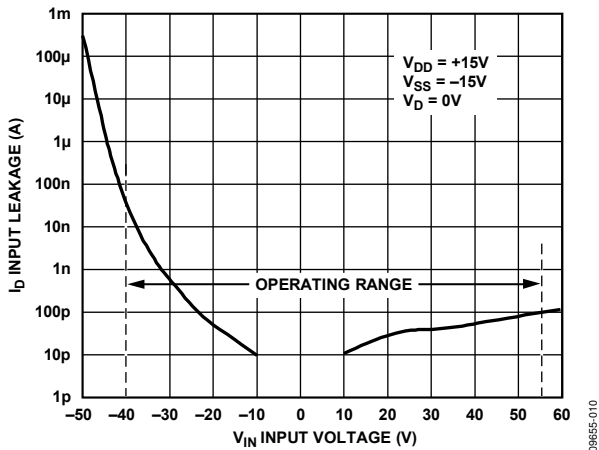

Figure 7. Output Leakage Current as a Function of V_S (Power Supplies On) During Overvoltage Conditions

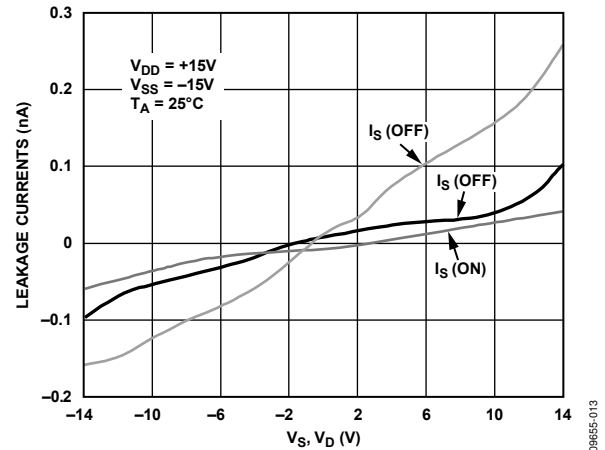

Figure 10. Leakage Currents as a Function of V_D (V_S)

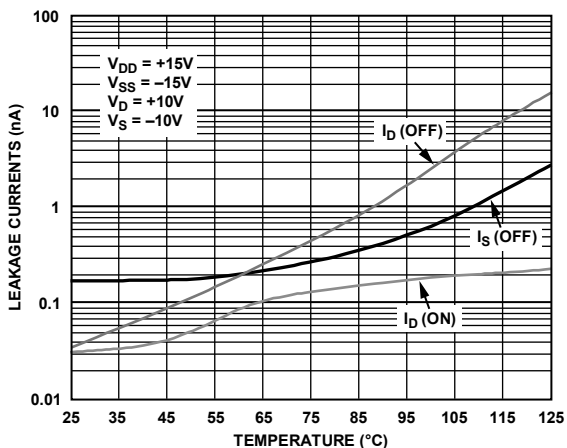

Figure 11. Leakage Currents as a Function of Temperature

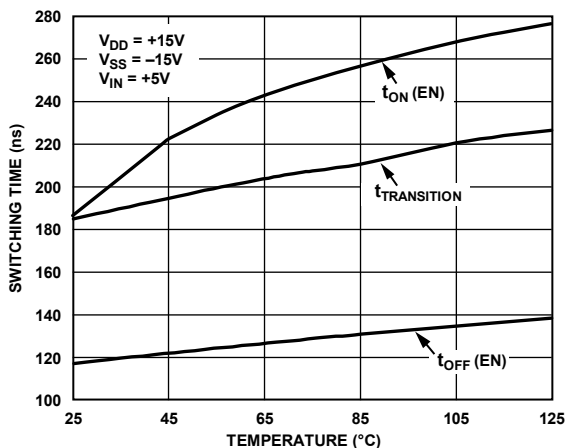

Figure 13. Switching Time vs. Temperature

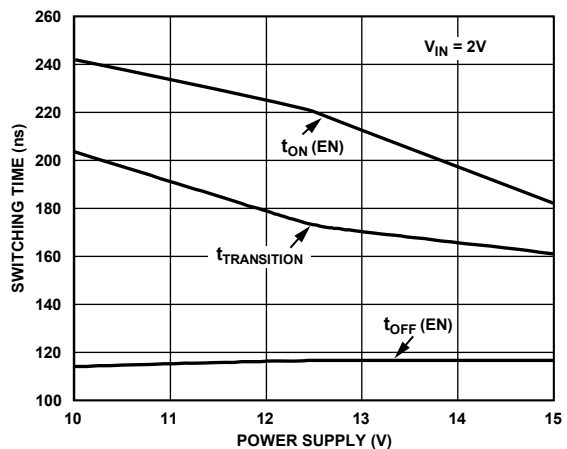

Figure 12. Switching Time vs. Power Supply

TERMINOLOGY

V_{DD} Most positive power supply potential.	t_{ON} (EN) Delay time between the 50% and 90% points of the digital input and switch on condition.
V_{SS} Most negative power supply potential.	t_{OFF} (EN) Delay time between the 50% and 90% points of the digital input and switch off condition.
GND Ground (0 V) reference.	t_{TRANSITION} Delay time between the 50% and 90% points of the digital inputs and the switch on condition when switching from one address state to another.
R_{ON} Ohmic resistance between D and S.	t_{OPEN} Off time measured between 80% points of both switches when switching from one address state to another.
R_{ON} Drift Change in R _{ON} when temperature changes by one degree Celsius.	V_{INL} Maximum input voltage for Logic 0.
R_{ON} Match Difference between the R _{ON} of any two channels.	V_{INH} Minimum input voltage for Logic 1.
I_S (Off) Source leakage current when the switch is off.	I_{INL} (I_{INH}) Input current of the digital input.
I_D (Off) Drain leakage current when the switch is off.	Off Isolation A measure of unwanted signal coupling through an off channel.
I_D, I_S (On) Channel leakage current when the switch is on.	Charge Injection A measure of the glitch impulse transferred from the digital input to the analog output during switching.
V_D (V_S) Analog Voltage on Terminal D and Terminal S.	I_{DD} Positive supply current.
C_S (Off) Channel input capacitance for off condition.	I_{SS} Negative supply current.
C_D (Off) Channel output capacitance for off condition.	
C_D, C_S (On) On switch capacitance.	
C_{IN} Digital input capacitance.	

THEORY OF OPERATION

The ADG528F multiplexer is capable of withstanding overvoltages from -40 V to $+55\text{ V}$, irrespective of whether the power supplies are present or not. Each channel of the multiplexer consists of an n-channel MOSFET, a p-channel MOSFET, and an n-channel MOSFET, connected in series. When the analog input exceeds the power supplies, one of the MOSFETs will switch off, limiting the current to submicroamp levels, thereby preventing the overvoltage from damaging any circuitry following the multiplexer. Figure 14 illustrates the channel architecture that enables these multiplexers to withstand continuous overvoltages.

When an analog input of $V_{SS} + 3\text{ V}$ to $V_{DD} - 1.5\text{ V}$ is applied to the ADG528F, the multiplexer behaves as a standard multiplexer, with specifications similar to a standard multiplexer, for example, the on-resistance is $400\ \Omega$ maximum. However, when an overvoltage is applied to the device, one of the three MOSFETs will turn off.

Figure 14 to Figure 17 show the conditions of the three MOSFETs for the various overvoltage situations. When the analog input applied to an on channel approaches the positive power supply line, the n-channel MOSFET turns off because the voltage on the analog input exceeds the difference between V_{DD} and the n-channel threshold voltage (V_{TN}). When a voltage more negative than V_{SS} is applied to the multiplexer, the p-channel MOSFET will turn off because the analog input is more negative than the difference between V_{SS} and the p-channel threshold voltage (V_{TP}). Because V_{TN} is nominally 1.5 V and V_{TP} is typically 3 V , the analog input range to the multiplexer is limited to -12 V to $+13.5\text{ V}$ when a $\pm 15\text{ V}$ power supply is used.

When the power supplies are present but the channel is off, again either the p-channel MOSFET or one of the n-channel MOSFETs will turn off when an overvoltage occurs.

Finally, when the power supplies are off, the gate of each MOSFET will be at ground. A negative overvoltage switches on the first n-channel MOSFET but the bias produced by the overvoltage causes the p-channel MOSFET to remain turned off. With a positive overvoltage, the first MOSFET in the series will remain off because the gate to source voltage applied to this MOSFET is negative.

During fault conditions, the leakage current into and out of the ADG528F is limited to a few microamps. This protects the multiplexer and succeeding circuitry from over stresses as well as protecting the signal sources, which drive the multiplexer. Also, the other channels of the multiplexer will be undisturbed by the overvoltage and will continue to operate normally.

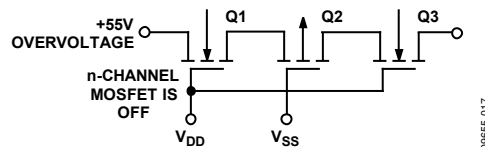

Figure 14. $+55\text{ V}$ Overvoltage Input to the On Channel

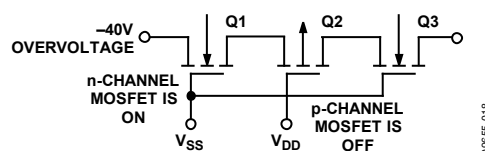

Figure 15. -40 V Overvoltage on an Off Channel with Multiplexer Power On

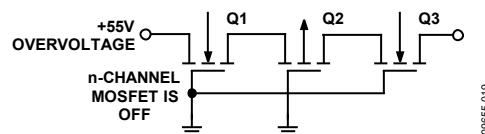

Figure 16. $+55\text{ V}$ Overvoltage with Power Off

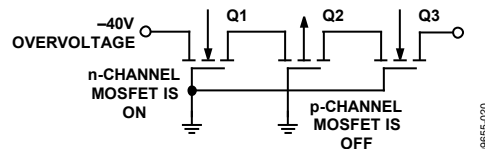

Figure 17. -40 V Overvoltage with Power Off

TEST CIRCUITS

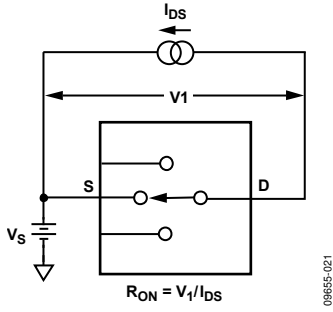

Figure 18. On Resistance

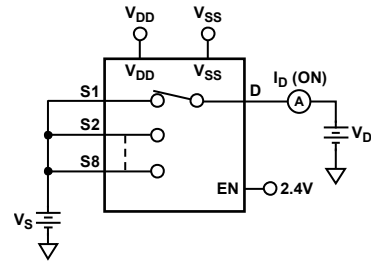

Figure 21. I_D (On)

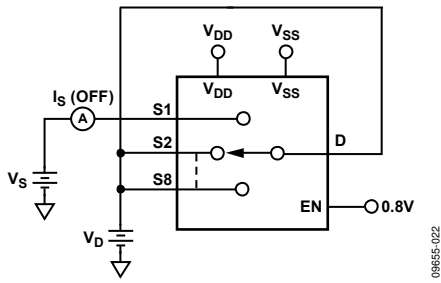

Figure 19. I_S (Off)

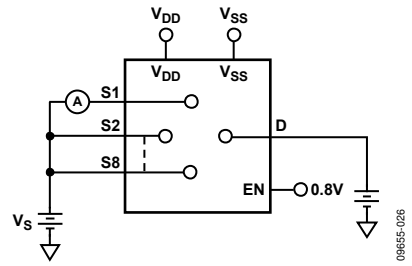

Figure 22. Input Leakage Current (with Overvoltage)

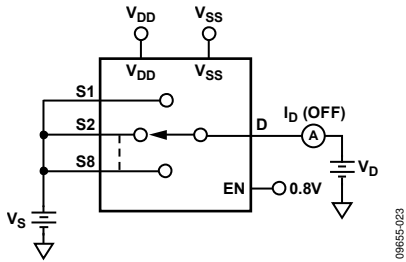

Figure 20. I_D (Off)

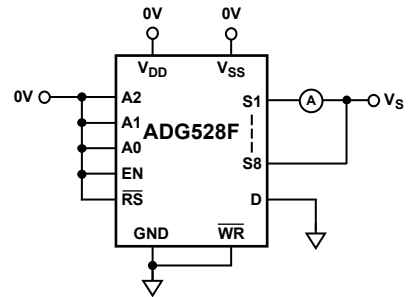

Figure 23. Input Leakage Current (with Power Supplies Off)

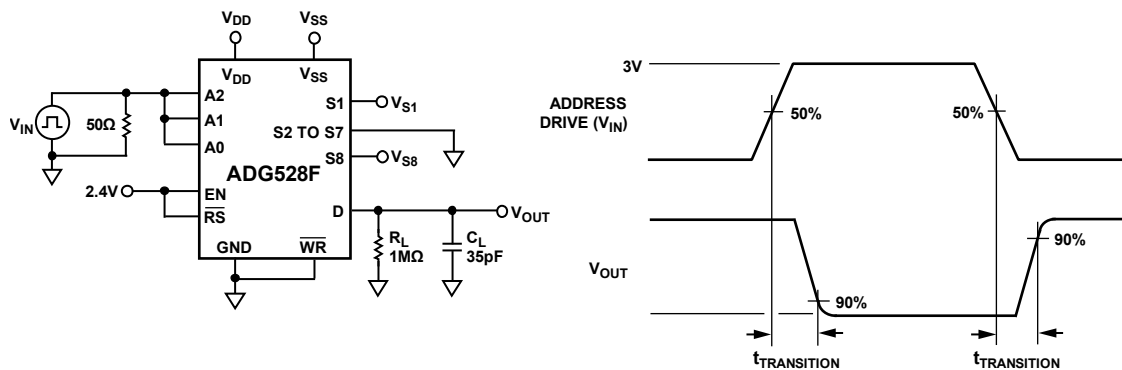

Figure 24. Switching Time of Multiplexer, $t_{\text{TRANSITION}}$

09655-024

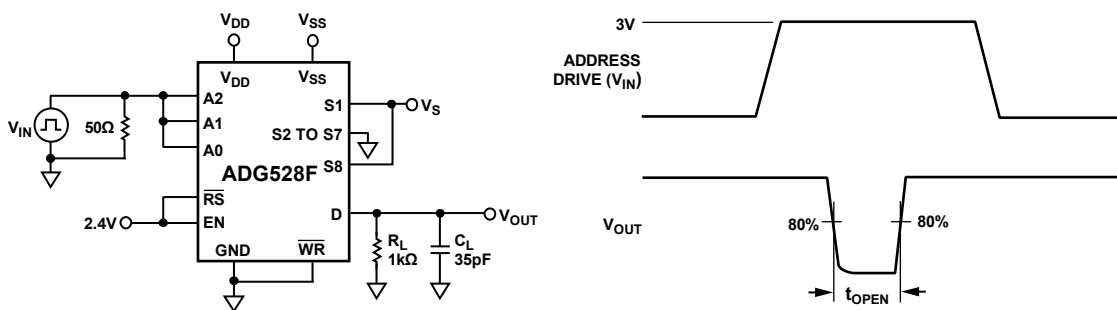

Figure 25. Break-Before-Make Delay, t_{OPEN}

09655-028

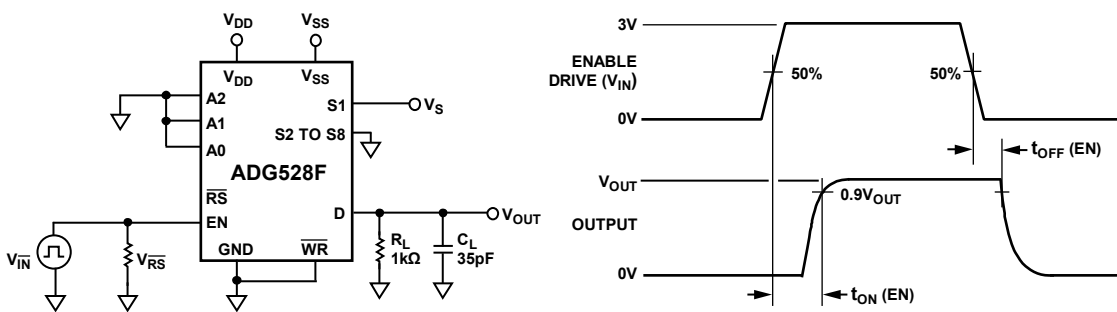

Figure 26. Enable Delay, $t_{\text{ON}}(\text{EN})$, $t_{\text{OFF}}(\text{EN})$

09655-030

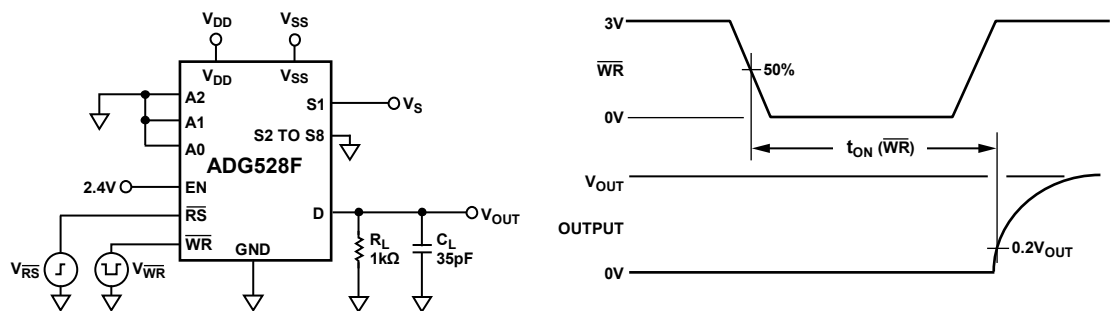

Figure 27. Write Turn-On Time, $t_{\text{ON}}(\overline{\text{WR}})$

09655-031

ADG528F

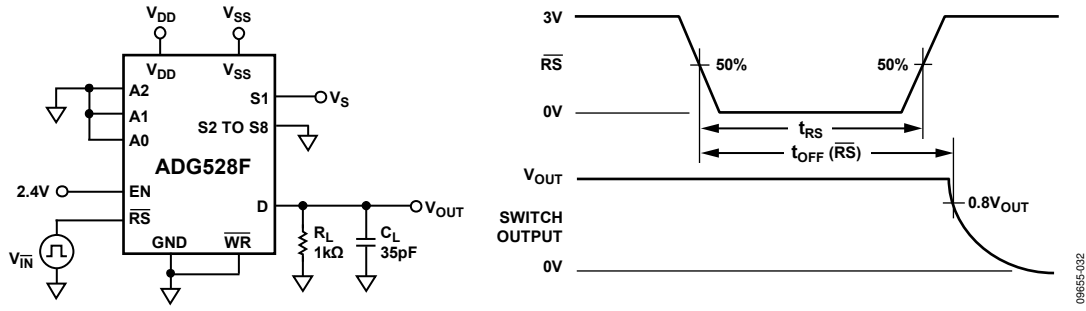

Figure 28. Reset Turn-Off Time, $t_{OFF}(\overline{RS})$

09655-032

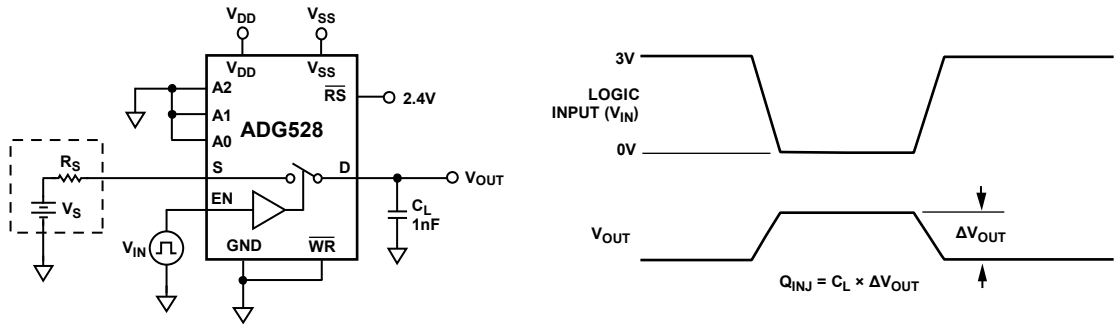

Figure 29. Charge Injection

09655-033

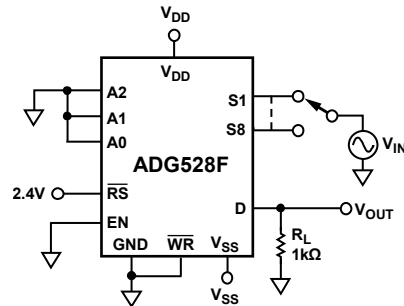
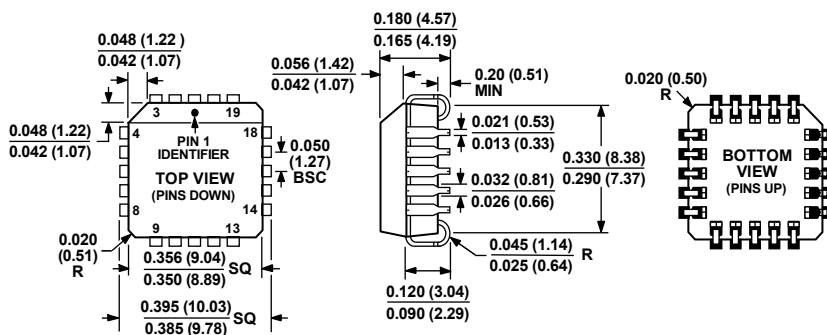

Figure 30. Off Isolation

0965-034

OUTLINE DIMENSIONS



COMPLIANT TO JEDEC STANDARDS MO-047-AA
 CONTROLLING DIMENSIONS ARE IN INCHES; MILLIMETER DIMENSIONS
 (IN PARENTHESES) ARE ROUNDED-OFF INCH EQUIVALENTS FOR
 REFERENCE ONLY AND ARE NOT APPROPRIATE FOR USE IN DESIGN.

Figure 31. 20-Lead Plastic Leaded Chip Carrier [PLCC]
 (P-20)

Dimensions shown in inches and (millimeters)

ORDERING GUIDE

Model ¹	Temperature Range	Package Description	Package Option
ADG528FBP	-40°C to +85°C	20-Lead PLCC	P-20
ADG528FBPZ	-40°C to +85°C	20-Lead PLCC	P-20

¹ Z = RoHS Compliant Part.

ADG528F

NOTES