



SpeedPLUS™ 10-Bit, 20MHz, +3V Supply ANALOG-TO-DIGITAL CONVERTER

FEATURES

- +2.7V TO +3.7V SUPPLY OPERATION
- INTERNAL REFERENCE
- LOW POWER: 52mW at +3V
- SINGLE-ENDED INPUT RANGE: 1V to 2V
- WIDEBAND TRACK/HOLD: 350MHz
- SSOP-28 PACKAGE

APPLICATIONS

- PORTABLE INSTRUMENTATION
- IF AND BASEBAND COMMUNICATIONS
- CABLE MODEMS
- SET-TOP BOXES
- PORTABLE TEST EQUIPMENT
- COMPUTER SCANNERS

DESCRIPTION

The ADS900 is a high-speed pipelined Analog-to-Digital Converter (ADC). This complete converter includes a high bandwidth track-and-hold, a 10-bit quantizer, and an internal reference.

The ADS900 employs digital error correction techniques to provide excellent differential linearity for demanding imaging applications. Its low distortion and high SNR give the extra margin needed for telecommunications, video and test instrumentation applications.

This high-performance ADC is specified for performance at a 20MHz sampling rate. The ADS900 is available in an SSOP-28 package.

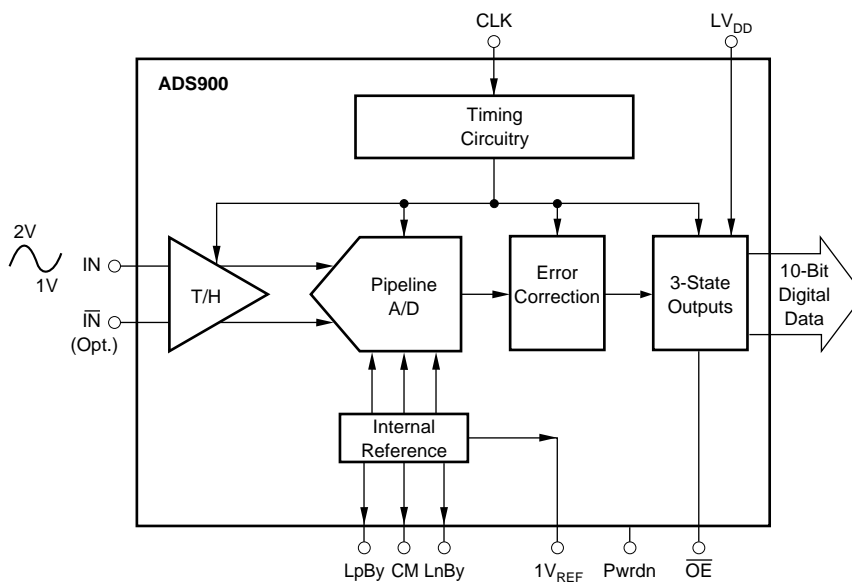

Please be aware that an important notice concerning availability, standard warranty, and use in critical applications of Texas Instruments semiconductor products and disclaimers thereto appears at the end of this data sheet.

ABSOLUTE MAXIMUM RATINGS

+V _S	+6V
Analog Input	+V _S +0.3V
Logic Input	+V _S +0.3V
Case Temperature	+100°C
Junction Temperature	+150°C
Storage Temperature	+150°C



ELECTROSTATIC DISCHARGE SENSITIVITY

This integrated circuit can be damaged by ESD. Texas Instruments recommends that all integrated circuits be handled with appropriate precautions. Failure to observe proper handling and installation procedures can cause damage.

ESD damage can range from subtle performance degradation to complete device failure. Precision integrated circuits may be more susceptible to damage because very small parametric changes could cause the device not to meet its published specifications.

PACKAGE/ORDERING INFORMATION

PRODUCT	PACKAGE	PACKAGE DRAWING NUMBER	SPECIFIED TEMPERATURE RANGE	PACKAGE MARKING	ORDERING NUMBER ⁽¹⁾	TRANSPORT MEDIA
ADS900E	SSOP-28	324	-40°C to +85°C	ADS900E	ADS900E	Rails
"	"	"	"	ADS900E	ADS900E/1K	Tape and Reel

NOTE: (1) Models with a slash (/) are available only in Tape and Reel in the quantities indicated (e.g., /1K indicates 1000 devices per reel). Ordering 1000 pieces of "ADS900E/1K" will get a single 1000-piece Tape and Reel.

ELECTRICAL CHARACTERISTICS

At T_A = +25°C, V_S = LV_{DD} = +3V, Single-Ended Input, Sampling Rate = 20MHz, unless otherwise specified.

PARAMETER	CONDITIONS	TEMP	ADS900E			UNITS
			MIN	TYP	MAX	
Resolution Specified Temperature Range	Ambient Air		-40	10	+85	Bits °C
ANALOG INPUT Single-Ended Full Scale Input Range Differential Full Scale Input Range Common-Mode Voltage Analog Input Bias Current Input Impedance	(1Vp-p) (0.5Vp-pX 2)		+1.0 +1.25	1.5 1 1.25 5	+2.0 +1.75	V V V μA MΩ pF
DIGITAL INPUTS Logic Family High Input Voltage, V _{IH} Low Input Voltage, V _{IL} High Input Current, I _{IH} Low Input Current, I _{IL} Input Capacitance			TTL/HCT COMPATIBLE CMOS 2.0			V V μA μA pF
CONVERSION CHARACTERISTICS Start Conversion Sample Rate Data Latency		Full	RISING EDGE OF CONVERT CLOCK 10k			Samples/s Clk Cyc
				5	20M	

ELECTRICAL CHARACTERISTICS (Cont.)

At $T_A = +25^\circ\text{C}$, $V_S = +3\text{V}$, Single-Ended Input, Sampling Rate = 20MHz, unless otherwise specified.

PARAMETER	CONDITIONS	TEMP	ADS900E			UNITS
			MIN	TYP	MAX	
DYNAMIC CHARACTERISTICS						
Differential Linearity Error						
$f = 500\text{kHz}$ (Largest Code Error)		Full		± 0.7		LSBs
$f = 10\text{MHz}$ (Largest Code Error)		Full		± 0.7	± 1.0	LSBs
No Missing Codes		Full		Guaranteed		
Integral Nonlinearity Error, $f = 500\text{kHz}$		Full		± 3.5		LSBs
Spurious Free Dynamic Range ⁽¹⁾						
$f = 500\text{kHz}$ (-1dBFS ⁽²⁾ input)		Full		53		dBFS ⁽²⁾
$f = 10\text{MHz}$ (-1dBFS ⁽²⁾ input)		Full	47	53		dBFS
Two-Tone Intermodulation Distortion ⁽³⁾						
$f = 4.5\text{MHz}$ and 5.0MHz (-7dBFS each tone)		$+25^\circ\text{C}$		50		dBc
Signal-to-Noise Ratio (SNR)						
$f = 500\text{kHz}$ (-1dBFS input)		Full		49		dB
$f = 10\text{MHz}$ (-1dBFS input)		Full	45	49		dB
Signal-to-(Noise + Distortion) (SINAD)						
$f = 500\text{kHz}$ (-1dBFS input)		Full		48		dB
$f = 3.58\text{MHz}$ (-1dBFS input)		Full		48		dB
$f = 10\text{MHz}$ (-1dBFS input)		Full	44	48		dB
Differential Gain Error	NTSC, PAL			2.3		%
Differential Phase Error	NTSC, PAL			1		degrees
Output Noise	Input Grounded			0.2		LSBs rms
Aperture Delay Time				2		ns
Aperture Jitter				7		ps rms
Analog Input Bandwidth						
Small Signal	-20dBFS Input	$+25^\circ\text{C}$		350		MHz
Full Power	0dBFS Input	$+25^\circ\text{C}$		100		MHz
Overshoot Recovery Time ⁽⁴⁾	1.5X FS Input	$+25^\circ\text{C}$		2		ns
DIGITAL OUTPUTS						
Logic Family	$C_L = 15\text{pF}$			TTL/HCT COMPATIBLE CMOS		
Logic Coding				Straight Offset Binary		
High Output Voltage, V_{OH}			+2.4		V_{DD}	V
Low Output Voltage, V_{OL}					+0.4	V
3-State Enable Time	$\overline{OE} = L$			20	40	ns
3-State Disable Time	$\overline{OE} = H$			2	10	ns
Internal Pull-Down				50		k Ω
Power-Down Enable Time	PwrDn = L			133		ns
Power-Down Disable Time	PwrDn = H			18		ns
Internal Pull-Down				50		k Ω
ACCURACY						
Gain Error	$f_S = 2.5\text{MHz}$	$+25^\circ\text{C}$		8	± 10	%FS
Input Offset	Referred to Ideal Midscale	Full		15	± 60	mV
Power Supply Rejection (Gain)	$\Delta V_S = +10\%$	Full		55		dB
Power Supply Rejection (Offset)		Full		62		dB
Internal Positive Reference Voltage		Full		+1.75		V
Internal Negative Reference Voltage		Full		+1.25		V
POWER SUPPLY REQUIREMENTS						
Supply Voltage: $+V_S$	Operating	Full	+2.7	+3	+3.7	V
Supply Current: $+I_S$	Operating	Full		18	22	mA
Power Dissipation	Operating, +3V	Full		54	66	mW
		25°C		52		mW
Power Dissipation (Power Down)	+3V	Full		10		mW
Thermal Resistance, θ_{JA}						
SSOP-28				89		$^\circ\text{C/W}$

NOTES: (1) Spurious Free Dynamic Range refers to the magnitude of the largest harmonic. (2) dBFS means dB relative to full scale. (3) Two-tone intermodulation distortion is referred to the largest fundamental tone. This number will be 6dB higher if it is referred to the magnitude of the two-tone fundamental envelope. (4) No rollover of bits.

PIN CONFIGURATION

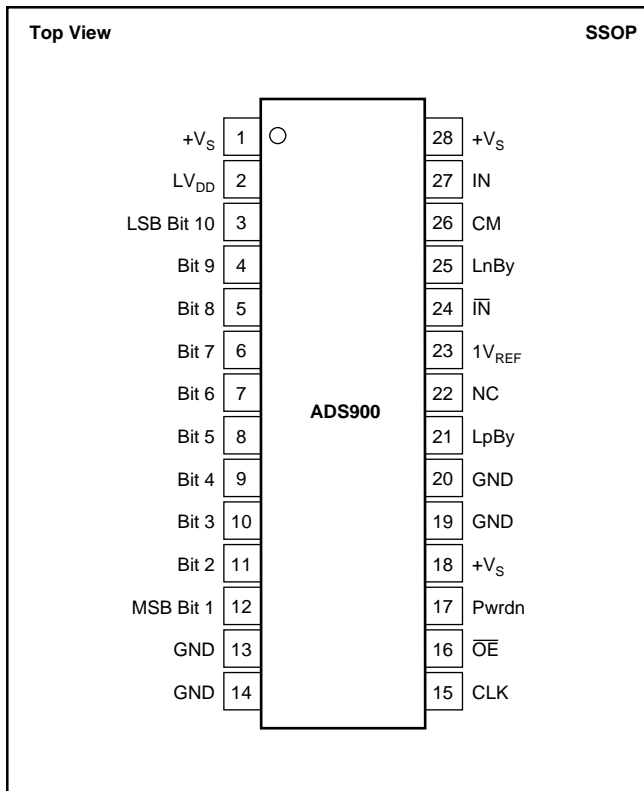

PIN DESCRIPTIONS

PIN	DESIGNATOR	DESCRIPTION
1	+V _S	Analog Supply
2	LV _{DD}	Output Logic Driver Supply Voltage
3	Bit 10	Data Bit 10 (D0) (LSB)
4	Bit 9	Data Bit 9 (D1)
5	Bit 8	Data Bit 8 (D2)
6	Bit 7	Data Bit 7 (D3)
7	Bit 6	Data Bit 6 (D4)
8	Bit 5	Data Bit 5 (D5)
9	Bit 4	Data Bit 4 (D6)
10	Bit 3	Data Bit 3 (D7)
11	Bit 2	Data Bit 2 (D8)
12	Bit 1	Data Bit 1 (D9) (MSB)
13	GND	Analog Ground
14	GND	Analog Ground
15	CLK	Convert Clock Input
16	$\overline{\text{OE}}$	Output Enable, Active Low
17	Pwrdn	Power Down Pin
18	+V _S	Analog Supply
19	GND	Analog Ground
20	GND	Analog Ground
21	LpBy	Positive Ladder Bypass
22	NC	No Connection
23	1V _{REF}	1V Reference Output
24	$\overline{\text{IN}}$	Complementary Input
25	LnBy	Negative Ladder Bypass
26	CM	Common-Mode Voltage Output
27	IN	Analog Input
28	+V _S	Analog Supply

TIMING DIAGRAM

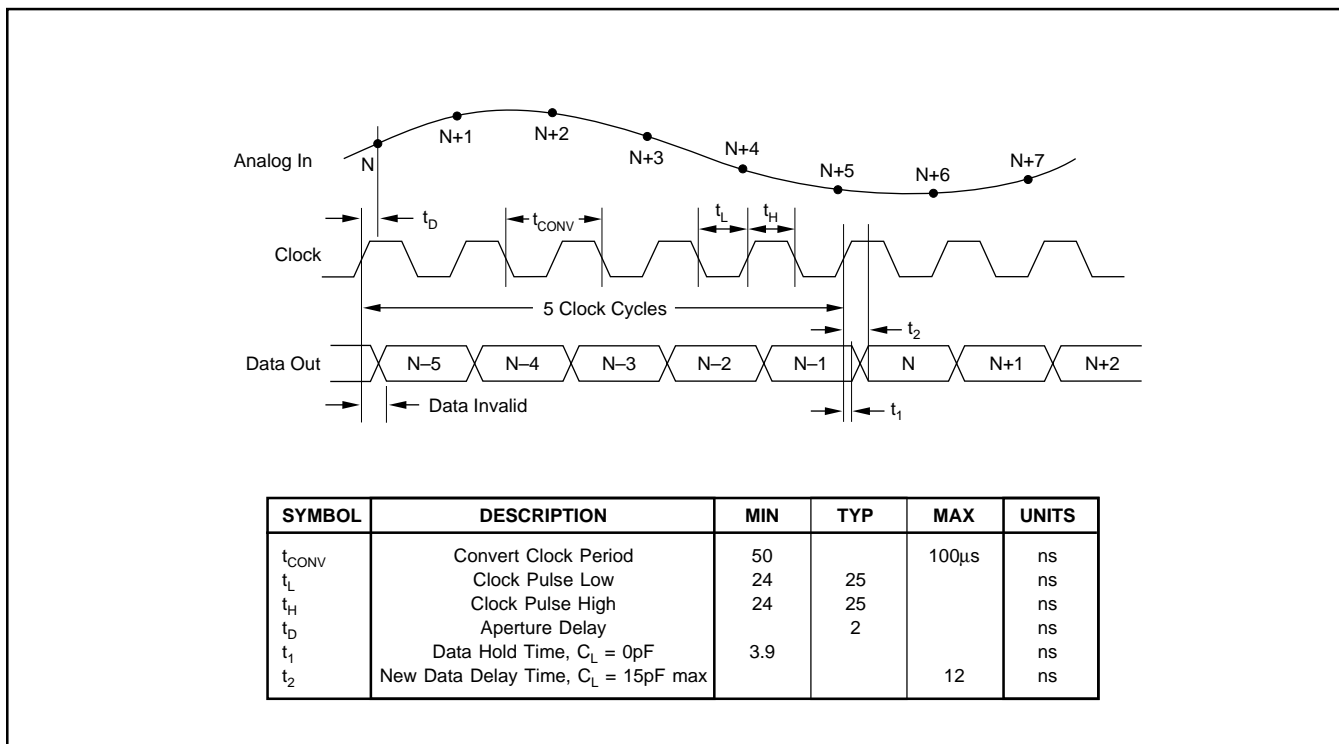

TYPICAL CHARACTERISTICS

At $T_A = +25^\circ\text{C}$, $V_S = LV_{DD} = +3\text{V}$, Single-Ended Input, Sampling Rate = 20MHz, unless otherwise specified.

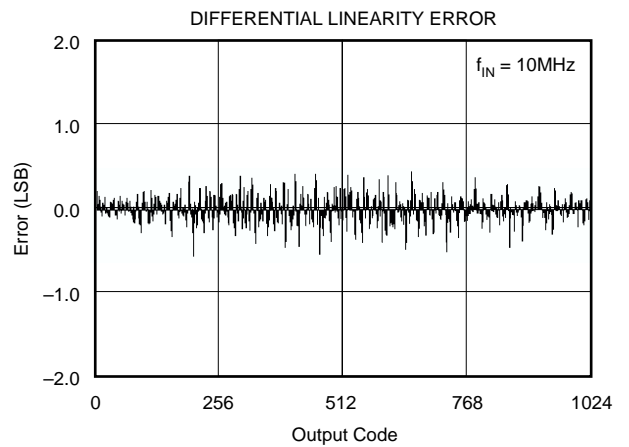
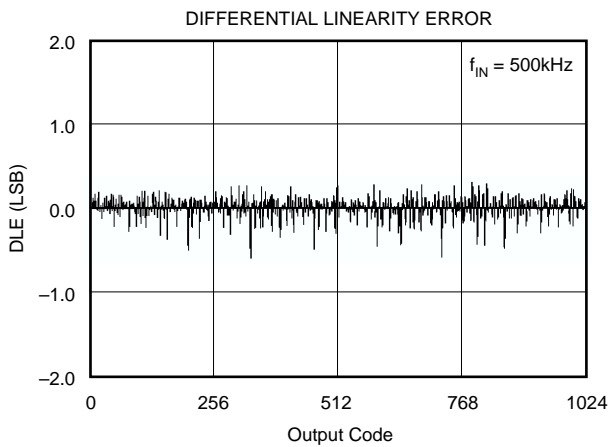
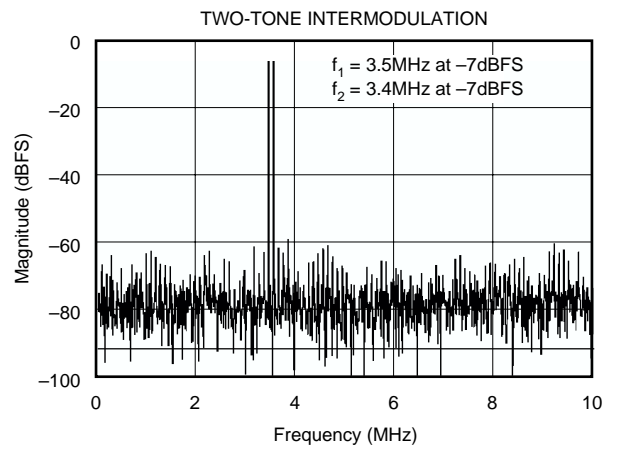
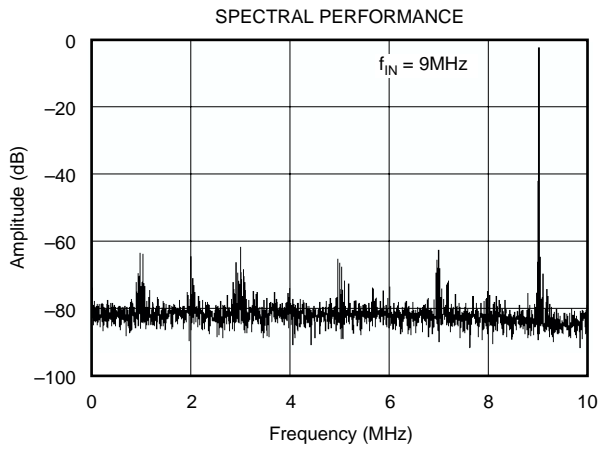
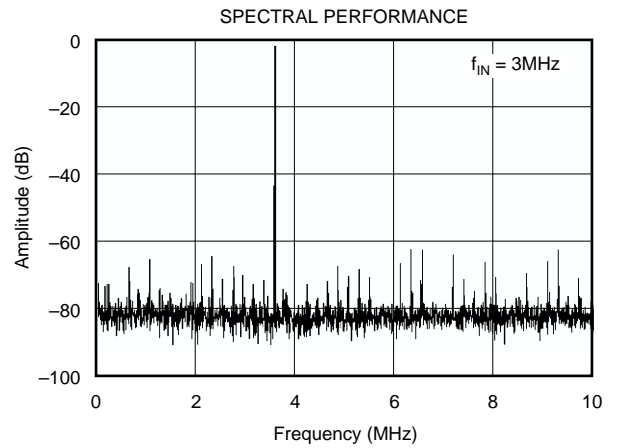
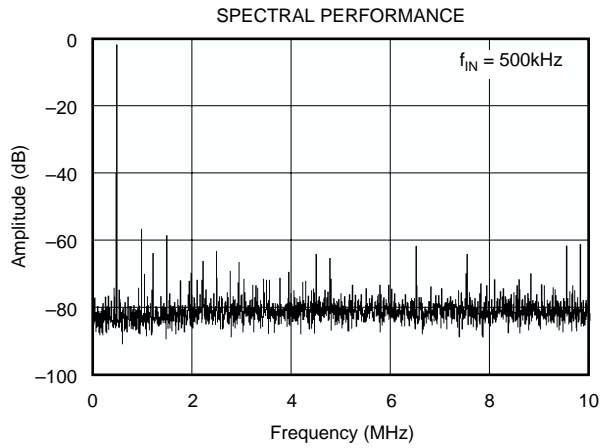

TYPICAL CHARACTERISTICS (Cont.)

At $T_A = +25^\circ\text{C}$, $V_S = LV_{DD} = +3\text{V}$, Single-Ended Input, Sampling Rate = 20MHz, unless otherwise specified.

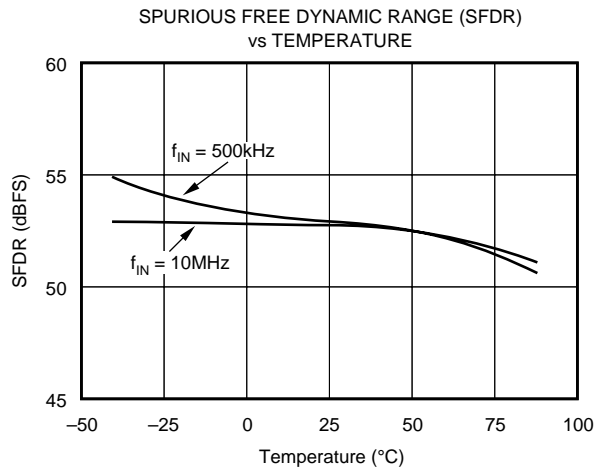
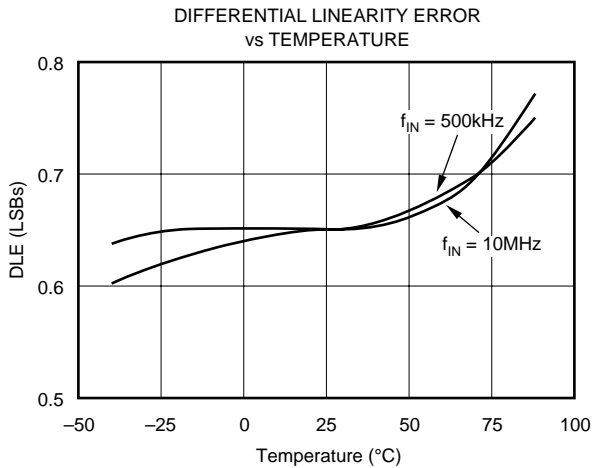
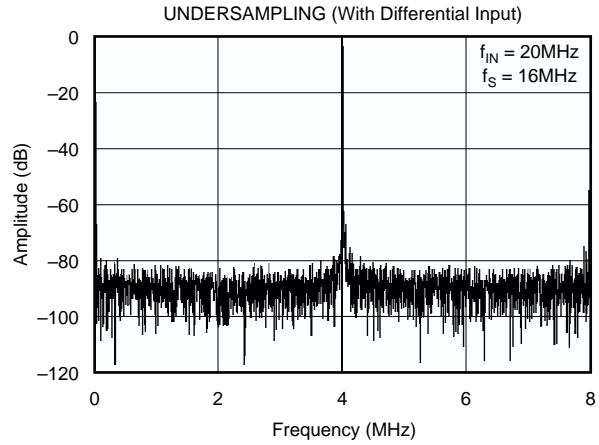
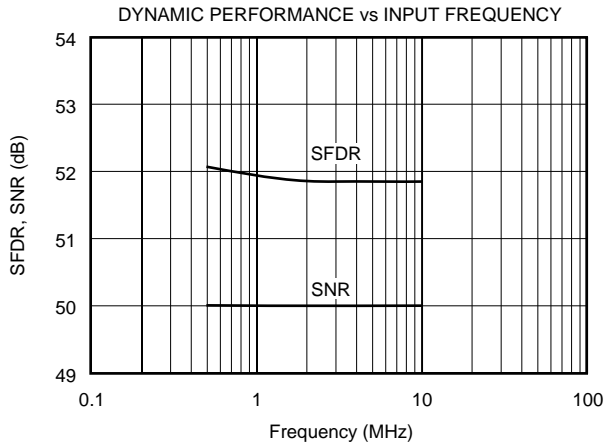
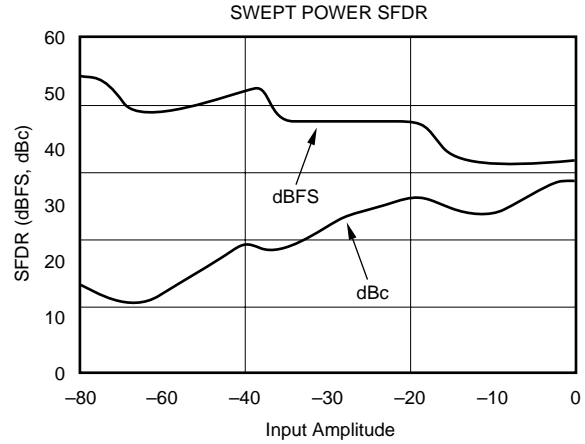
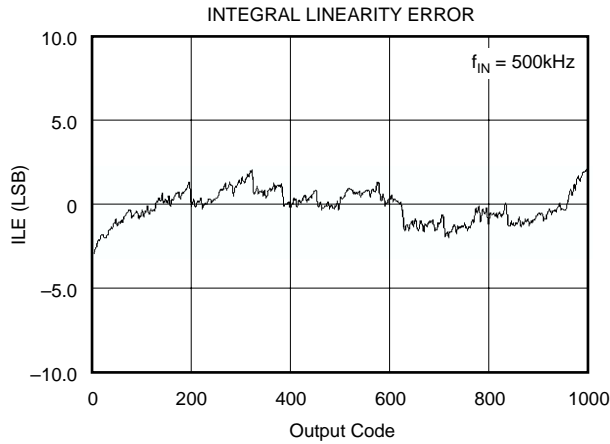

TYPICAL CHARACTERISTICS (Cont.)

At $T_A = +25^\circ\text{C}$, $V_S = LV_{DD} = +3\text{V}$, Single-Ended Input, Sampling Rate = 20MHz, unless otherwise specified.

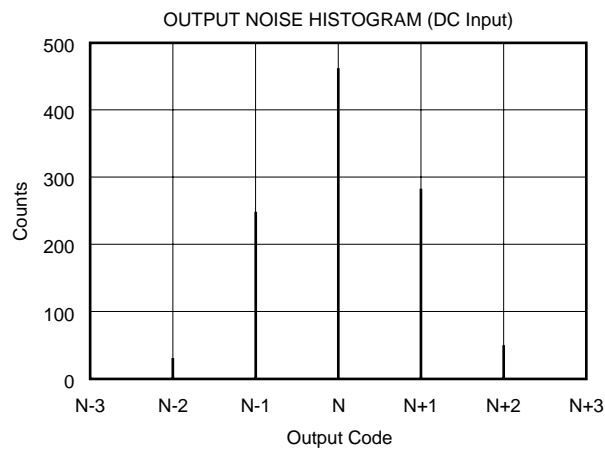
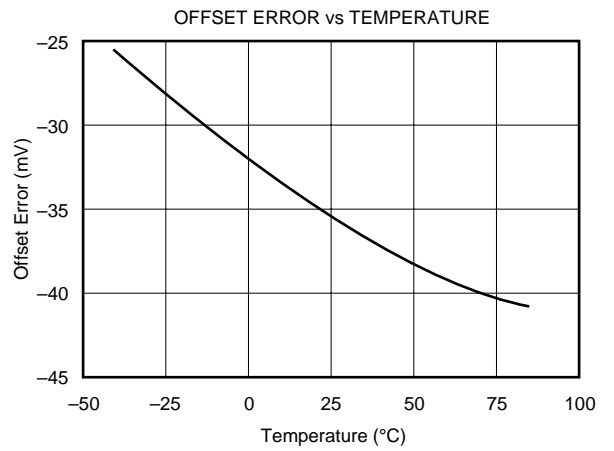
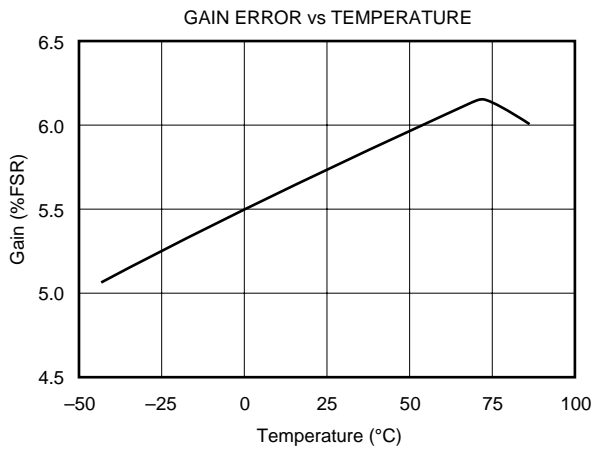
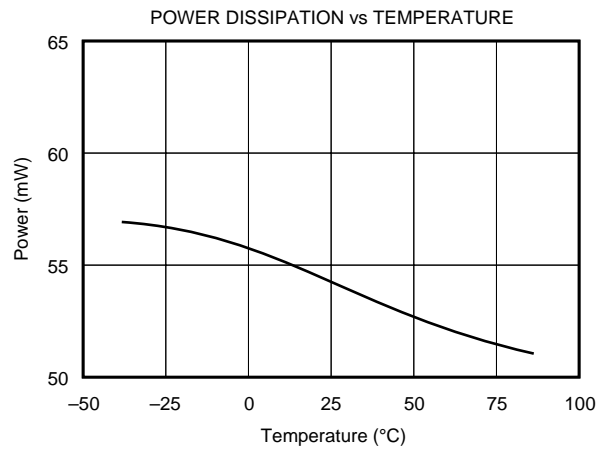
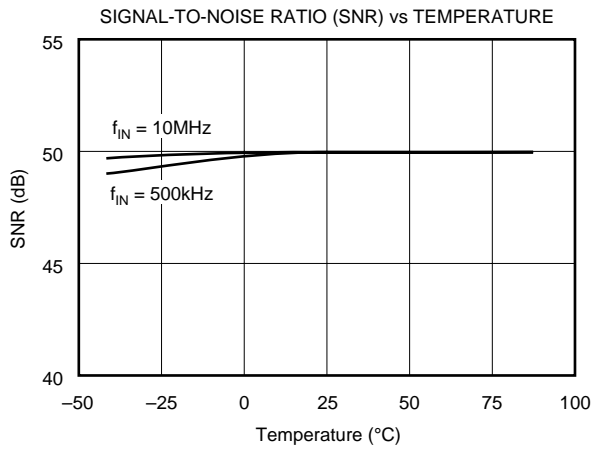

THEORY OF OPERATION

The ADS900 is a high speed sampling ADC that utilizes a pipeline architecture. The fully differential topology and digital error correction guarantee 10-bit resolution. The track-and-hold circuit is shown in Figure 1. The switches are controlled by an internal clock which has a non-overlapping two phase signal, $\phi 1$ and $\phi 2$. At the sampling time the input signal is sampled on the bottom plates of the input capacitors. In the next clock phase, $\phi 2$, the bottom plates of the input capacitors are connected together and the feedback capacitors are switched to the op amp output. At this time the charge redistributes between C_1 and C_H , completing one track-and-hold cycle. The differential output is a held DC representation of the analog input at the sample time. In the normal mode of operation, the complementary input is tied to the common-mode voltage. In this case, the track-and-hold circuit converts a single-ended input signal into a fully differential signal for the quantizer. Consequently, the input signal gets amplified by a gain or two, which improves the signal-to-noise performance. Other parameters such as small-signal and full-power bandwidth, and wideband noise are also defined in this stage.

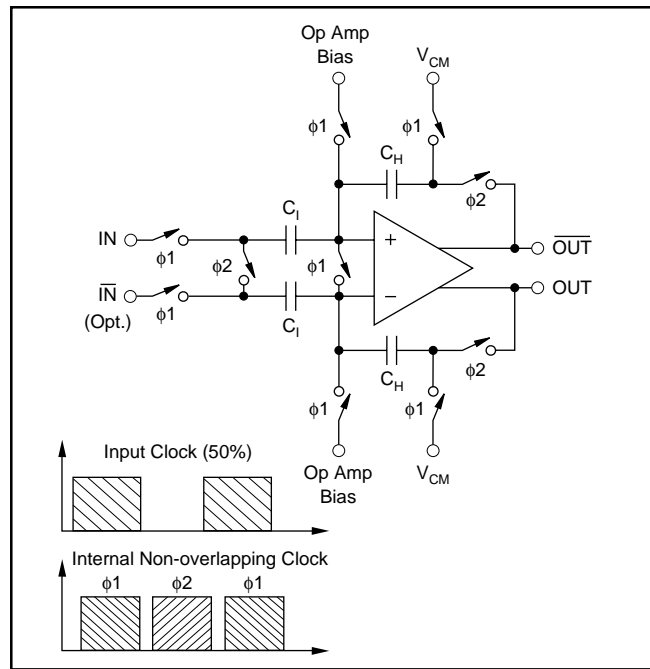

FIGURE 1. Input Track-And-Hold Configuration with Timing Signals.

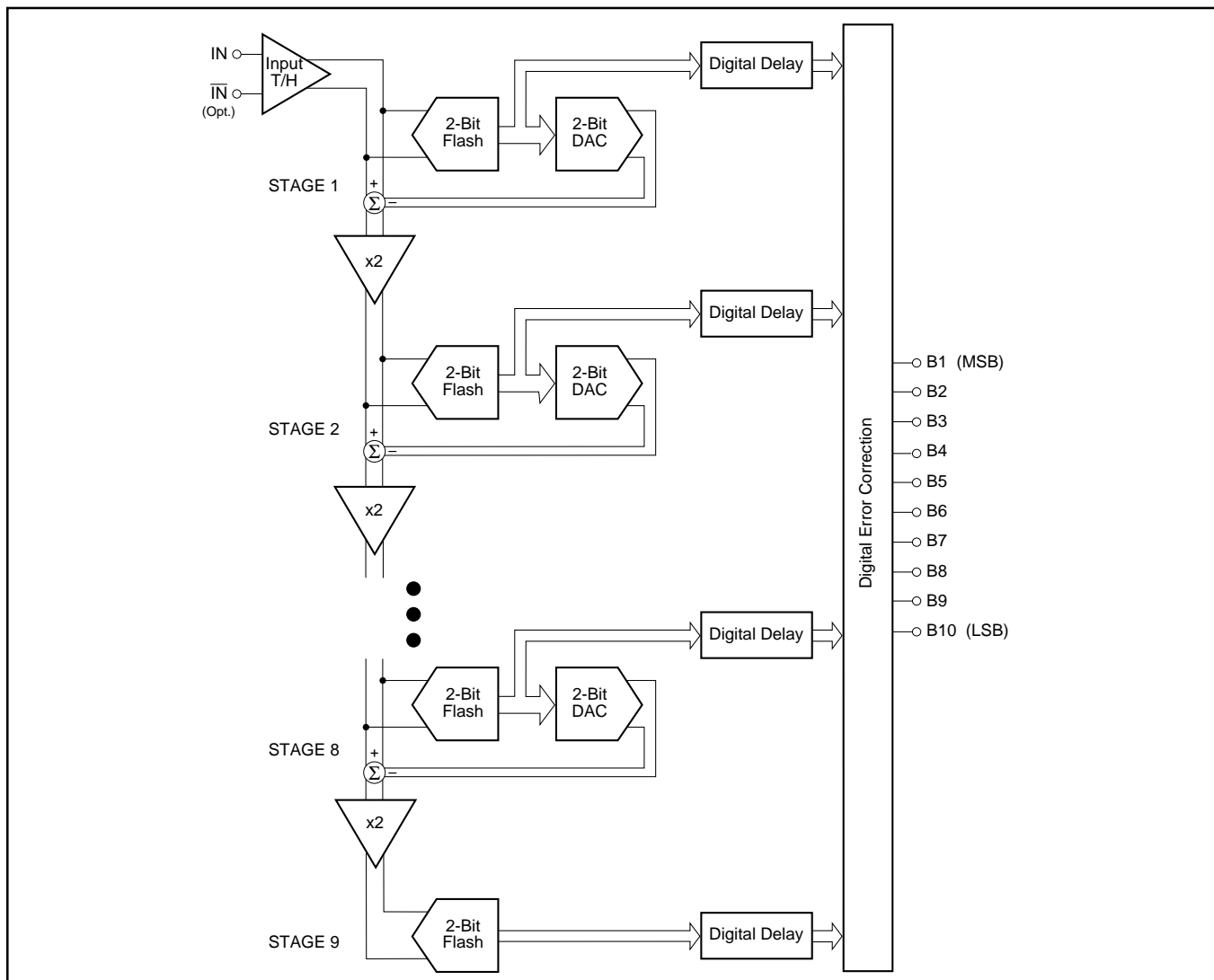

FIGURE 2. Pipeline A/D Architecture.

The pipelined quantizer architecture has 9 stages with each stage containing a two-bit quantizer and a two bit Digital-to-Analog Converter (DAC), as shown in Figure 2. Each two-bit quantizer stage converts on the edge of the sub-clock, which is the same frequency of the externally applied clock. The output of each quantizer is fed into its own delay line to time-align it with the data created from the following quantizer stages. This aligned data is fed into a digital error correction circuit which can adjust the output data based on the information found on the redundant bits. This technique provides the ADS900 with excellent differential linearity and guarantees no missing codes at the 10-bit level.

The ADS900 includes an internal reference circuit that provides the bias voltages for the internal stages (for details see “Internal Reference”). A midpoint voltage is established by the built-in resistor ladder that is made available at pin 26 “CM”. This voltage can be used to bias the inputs up to the recommended common-mode voltage or used to level shift the input driving circuitry. The ADS900 can be used in both a single-ended or differential input configuration. When operated in single-ended mode, the reference midpoint (pin 26) should be tied to the inverting input, pin 24.

To accommodate a bipolar signal swing, the ADS900 operates with a common-mode voltage (V_{CM}) which is derived from the internal references. Due to the symmetric resistor ladder inside the ADS900, the V_{CM} is situated between the top and bottom reference voltage. The following equation can be used for calculating the common-mode voltage level.

$$V_{CM} = (REFT + REFB)/2 \quad (1)$$

DIGITAL OUTPUT DATA

The 10-bit output data is provided at CMOS logic levels. There is a 5.0 clock cycle data latency from the start convert signal to the valid output data. The standard output coding is Straight Offset Binary where a full scale input signal corresponds to all “1’s” at the output. The digital outputs of the ADS900 can be set to a high impedance state by driving the \overline{OE} (pin 16) with a logic “HI”. Normal operation is achieved with pin 16 “LO” or Floating due to internal pull-down resistor. This function is provided for testability

SINGLE-ENDED INPUT ($I_N = 1.5V$ DC)	STRAIGHT OFFSET BINARY (SOB) PIN 12 FLOATING or LO
+FS ($I_N = +2V$)	1111111111
+FS -1LSB	1111111111
+FS -2LSB	1111111110
+3/4 Full Scale	1110000000
+1/2 Full Scale	1100000000
+1/4 Full Scale	1010000000
+1LSB	1000000001
Bipolar Zero ($I_N +1.5V$)	1000000000
-1LSB	0111111111
-1/4 Full Scale	0110000000
-1/2 Full Scale	0100000000
-3/4 Full Scale	0010000000
-FS +1LSB	0000000001
-FS ($I_N = +1V$)	0000000000

TABLE I. Coding Table for the ADS900.

purposes but is not recommended to be used dynamically. The capacitive loading on the digital outputs should be kept below 15pF.

APPLICATIONS

DRIVING THE ANALOG INPUTS

Figure 3 shows an example of an ac-coupled, single-ended interface circuit using high-speed op amps that operate on dual supplies (OPA650, OPA658, OPA680 and OPA681). The common-mode reference voltage (V_{CM}), here +1.5V, biases the bipolar, ground-referenced input signal. The capacitor C_1 and resistor R_1 form a high-pass filter with the -3dB frequency set at

$$f_{-3dB} = 1/(2 \pi R_1 C_1) \quad (2)$$

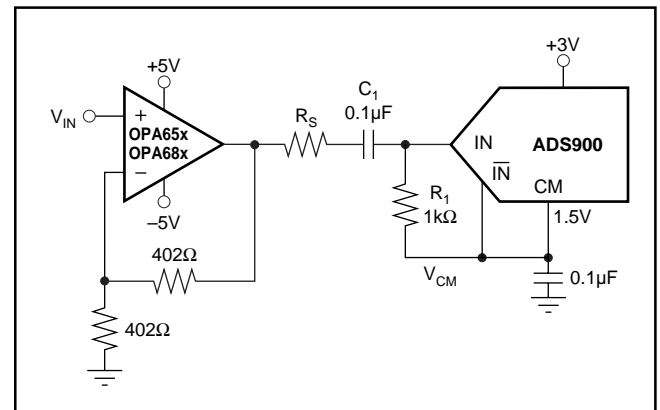

FIGURE 3. AC-Coupled Driver.

The values for C_1 and R_1 are not critical in most applications and can be set freely. The values shown correspond to a -3dB corner frequency of 1.6kHz.

Figure 4 depicts a circuit that can be used in single-supply applications. The common-mode voltage biases the op amp up to the appropriate common-mode voltage, for example $V_{CM} = +1.5V$. With the use of capacitor C_G the DC gain for the non-inverting op amp input is set to +1V/V. As a result the transfer function is modified to

$$V_{OUT} = V_{IN} \{(1 + R_F/R_G) + V_{CM}\} \quad (3)$$

Again, the input coupling capacitor C_1 and resistor R_1 form a high-pass filter. At the same time the input impedance is defined by R_1 . Resistor R_S isolates the op amp’s output from the capacitive load to avoid gain peaking or even oscillation. It can also be used to establish a defined roll-off for the wideband noise. Its value is usually between 10Ω and 100Ω.

DIFFERENTIAL MODE OF OPERATION

Some minor performance improvements in SFDR and THD can be realized by operating the ADS900 in its optional differential configuration. A RF-transformer with a center tap provides the best method of performing a single-ended to differential conversion and interface directly to the ADS900.

As a passive component, a transformer can be used to step-up the signal amplitude without adding noise or distortion. At the same time it electrically isolates the front-end from the converter. In order to achieve optimum performance and to bias the converter inputs up to the correct common-mode voltage the mid-reference pin “CM” can be tied directly to the center tap of the transformer.

Figure 6 shows an example for a single-ended DC-coupled interface circuit using one high-speed op amp to level-shift the ground-referenced input signal to condition it for the input requirements of the ADS900. With a +3V supply the

input signal swings 1Vp-p centered around a typical common-mode voltage of +1.5V. This voltage can be derived from the internal bottom reference (REFB = +1.25V) and then fed back through a resistor divider (R_1, R_2) to level shift the driving op amp (OPA680). A capacitor across R_2 will shunt most of the wideband noise to ground. Depending on the configured gain the values of resistors R_1 and R_2 must be adjusted since the offsetting voltage (V_{OS}) is amplified by the non-inverting gain, $1+(R_F/R_{IN})$. This example assumes the sum of R_1 and R_2 to be 5k Ω , drawing only 250 μ A from the bottom reference. Considerations for the selection of a

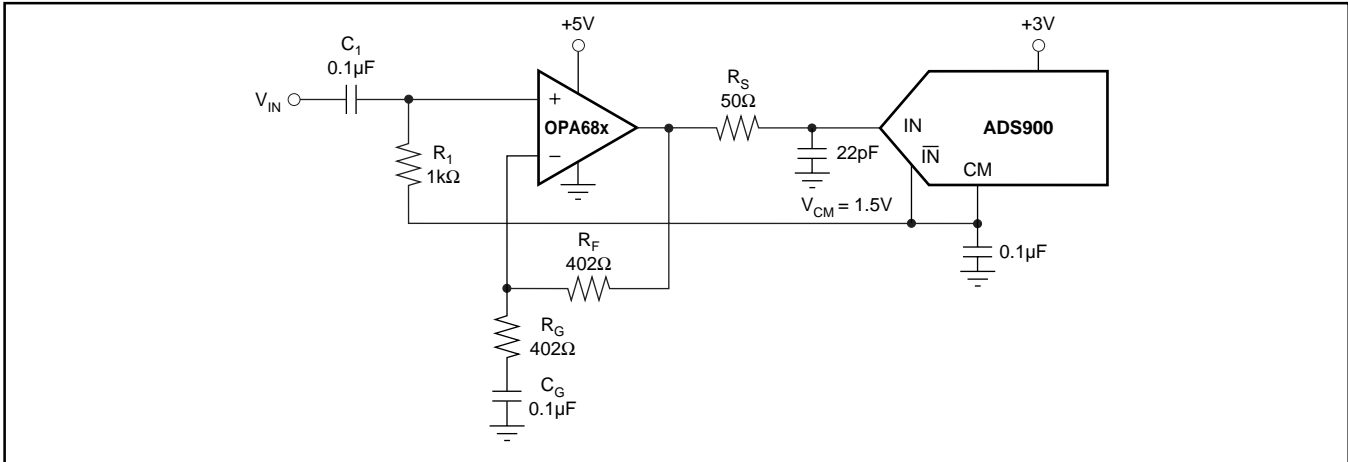

FIGURE 4. Driver Circuit Using Single Supply.

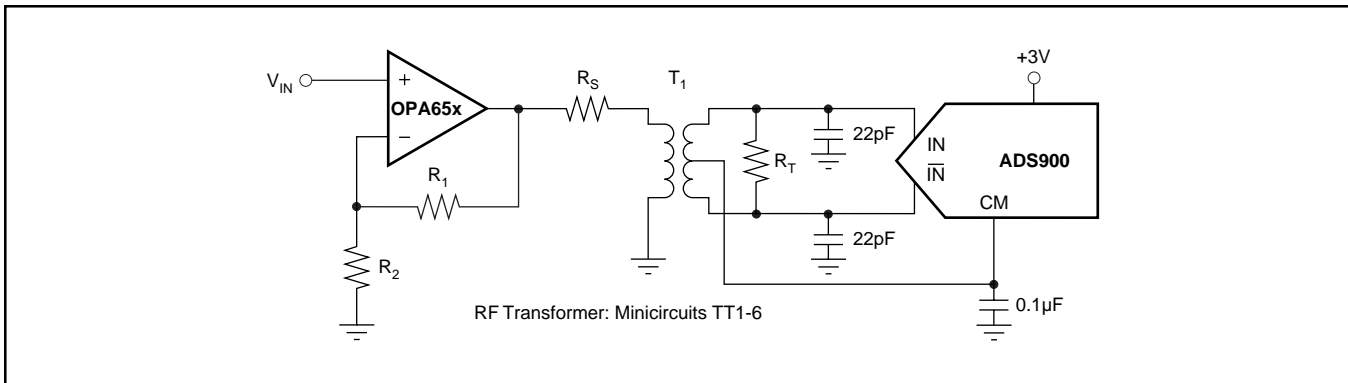

FIGURE 5. Single-Ended to Differential Drive Circuit Using a Transformer.

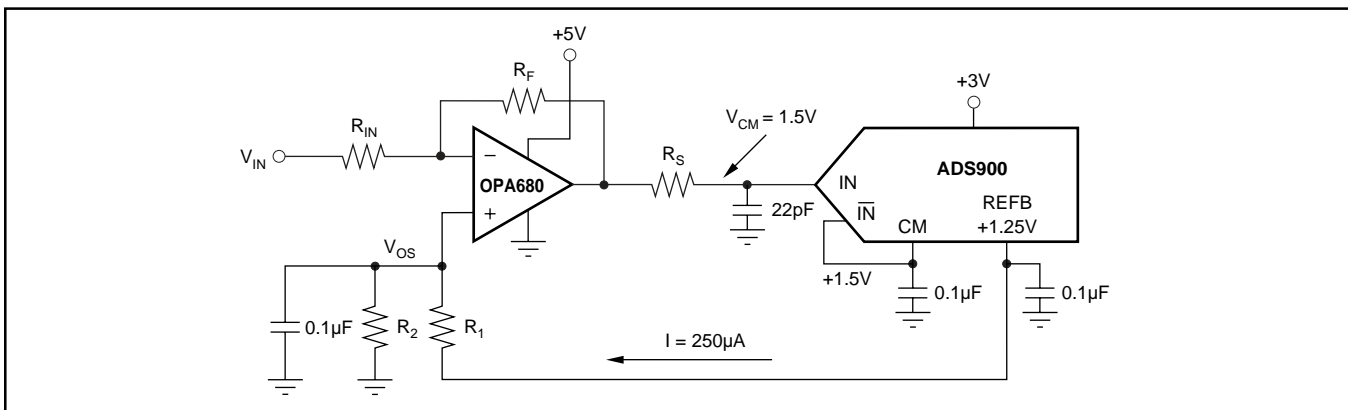

FIGURE 6. Single-Ended DC-Coupled Input Circuit.

proper op amp should include its output swing, input common-mode range, and bias current. It should be noted that any DC voltage difference between the inputs, IN and $\overline{\text{IN}}$, will show up as an offset at the output. At the same time an offset adjustment can be accomplished.

INTERNAL REFERENCE

The ADS900 features an internal pipeline reference that provides fixed reference voltages for the internal stages. As shown in Figure 7 a buffer for each the top and bottom reference is connected to the resistor ladder, which has a nominal resistance of $4\text{k}\Omega$ ($\pm 15\%$). The two outputs of the buffers are brought out at pin 21 (LpBy) and pin 25 (LnBy), primarily to connect external bypass capacitors, typically $0.1\mu\text{F}$, which will improve the performance. The buffers can drive limited external loads, for example for level shifting of the converter's interface circuit, however, the current draw should be limited to approximately 1mA.

Derived from the top reference of $+1.75\text{V}$ is an additional voltage of $+1.0\text{V}$. Note that this voltage, available on pin 23, is not buffered and care should be taken when external loads are applied. In normal operation, this pin is left unconnected and no bypassing components are required.

CLOCK INPUT REQUIREMENTS

The clock input of the ADS900 is designed to accommodate either $+5\text{V}$ or $+3\text{V}$ CMOS logic levels. To drive the clock input with a minimum amount of duty cycle variation and support maximum sampling rates (20Msps) high speed or advanced CMOS logic should be used (HC/HCT, AC/ACT). When digitizing at high sampling rates, a 50% duty cycle along with fast rise and fall times (2ns or less) are recom-

mended to meet the rated performance specifications. However, the ADS900 performance is tolerant to duty cycle variations of as much as $\pm 10\%$ without degradation. For applications operating with input frequencies up to Nyquist or undersampling applications, special considerations must be made to provide a clock with very low jitter. Clock jitter leads to aperture jitter (t_A) which can be the ultimate limitation in achieving good SNR performance. The following equation shows the relationship between aperture jitter, input frequency and the signal-to-noise ratio:

$$\text{SNR} = 20\log_{10} [1/(2 \pi f_{\text{IN}} t_A)] \quad (4)$$

For example, in the case of a 10MHz full-scale input signal and an aperture jitter of $t_A = 20\text{ps}$ the SNR is clock jitter limited to 58dB.

DIGITAL OUTPUTS

The digital outputs of the ADS900 are standard CMOS stages and designed to be compatible to both high speed TTL and CMOS logic families. The logic thresholds are for low-voltage CMOS: $V_{\text{OL}} = 0.4\text{V}$, $V_{\text{OH}} = 2.4\text{V}$, which allows the ADS900 to directly interface to 3V-logic. The digital outputs of the ADS900 uses a dedicated digital supply pin (pin 2, LV_{DD}) see Figure 8. By adjusting the voltage on LV_{DD} , the digital output levels will vary respectively. It is recommended to limit the fan-out to one to keep the capacitive loading on the data lines below the specified 15pF. If necessary, external buffers or latches may be used which provide the added benefit of isolating the ADC from any digital activities on the bus coupling back high frequency noise and degrading the performance.

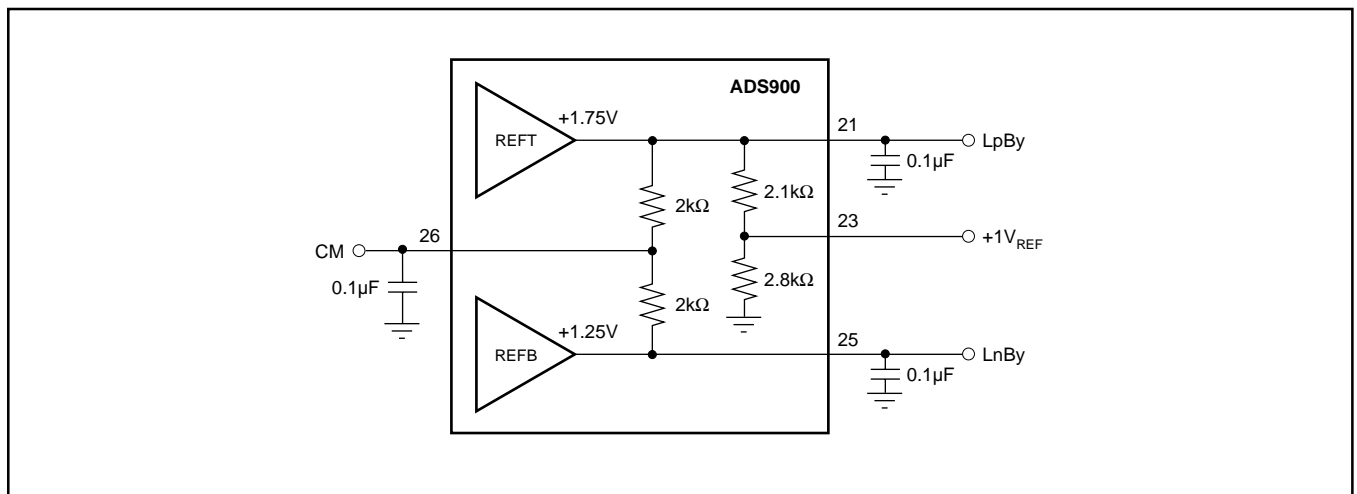

FIGURE 7. Internal Reference Structure and Recommended Reference Bypassing.

POWER-DOWN MODE

The ADS900's low power consumption can be reduced even further by initiating a power down mode. For this, the Power Down Pin (Pin 17) must be tied to a logic "High" reducing the current drawn from the supply by about 70%. In normal operation the power-down mode is disabled by an internal pull-down resistor (50k Ω).

During power-down the digital outputs are set in 3-state. With the clock applied, the converter does not accurately process the sampled signal. After removing the power-down condition the output data from the following 5 clock cycles is invalid (data latency).

DECOUPLING AND GROUNDING CONSIDERATIONS

The ADS900 has several supply pins, one of which is dedicated to only supply the output driver (LV_{DD}). The remaining supply pins are not divided into analog and digital supply pins since they are internally connected on the chip. For this reason it is recommended to treat the converter as an analog component and to power it from the analog supply only. Digital supply lines often carry high levels of noise which can couple back into the converter and limit the performance.

Because of its fast switching architecture, the converter also generates high frequency transients and noise that are fed back into the supply and reference lines. This requires that the supply and reference pins be sufficiently bypassed. Figure 9 shows the recommended decoupling scheme for the analog supplies. In most cases 0.1 μ F ceramic chip capacitors are adequate to keep the impedance low over a wide frequency range. Their effectiveness largely depends on the proximity to the individual supply pin. Therefore they should be located as close to the supply pins as possible.

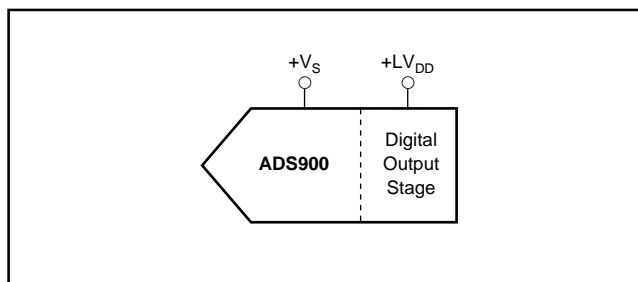

FIGURE 8. Independent Supply Connection for Output Stage.

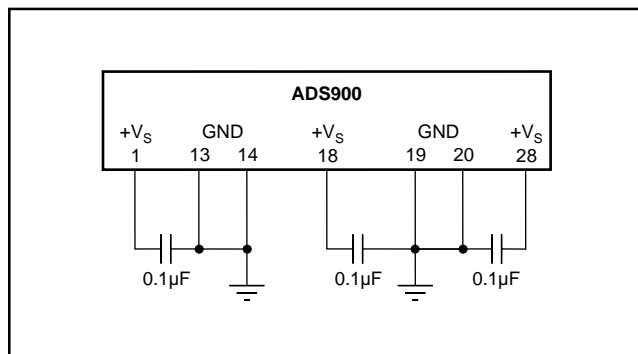

FIGURE 9. Recommended Bypassing for Analog Supply Pins.

PACKAGING INFORMATION

Orderable Device	Status (1)	Package Type	Package Drawing	Pins	Package Qty	Eco Plan (2)	Lead finish/ Ball material (6)	MSL Peak Temp (3)	Op Temp (°C)	Device Marking (4/5)	Samples
ADS900E	ACTIVE	SSOP	DB	28	50	RoHS & Green	NIPDAU	Level-2-260C-1 YEAR	-40 to 85	ADS900E	Samples
ADS900E/1K	ACTIVE	SSOP	DB	28	1000	RoHS & Green	NIPDAU	Level-1-260C-UNLIM	-40 to 85	ADS900E	Samples

(1) The marketing status values are defined as follows:

ACTIVE: Product device recommended for new designs.

LIFEBUY: TI has announced that the device will be discontinued, and a lifetime-buy period is in effect.

NRND: Not recommended for new designs. Device is in production to support existing customers, but TI does not recommend using this part in a new design.

PREVIEW: Device has been announced but is not in production. Samples may or may not be available.

OBSOLETE: TI has discontinued the production of the device.

(2) **RoHS:** TI defines "RoHS" to mean semiconductor products that are compliant with the current EU RoHS requirements for all 10 RoHS substances, including the requirement that RoHS substance do not exceed 0.1% by weight in homogeneous materials. Where designed to be soldered at high temperatures, "RoHS" products are suitable for use in specified lead-free processes. TI may reference these types of products as "Pb-Free".

RoHS Exempt: TI defines "RoHS Exempt" to mean products that contain lead but are compliant with EU RoHS pursuant to a specific EU RoHS exemption.

Green: TI defines "Green" to mean the content of Chlorine (Cl) and Bromine (Br) based flame retardants meet JS709B low halogen requirements of <=1000ppm threshold. Antimony trioxide based flame retardants must also meet the <=1000ppm threshold requirement.

(3) MSL, Peak Temp. - The Moisture Sensitivity Level rating according to the JEDEC industry standard classifications, and peak solder temperature.

(4) There may be additional marking, which relates to the logo, the lot trace code information, or the environmental category on the device.

(5) Multiple Device Markings will be inside parentheses. Only one Device Marking contained in parentheses and separated by a "~" will appear on a device. If a line is indented then it is a continuation of the previous line and the two combined represent the entire Device Marking for that device.

(6) Lead finish/Ball material - Orderable Devices may have multiple material finish options. Finish options are separated by a vertical ruled line. Lead finish/Ball material values may wrap to two lines if the finish value exceeds the maximum column width.

Important Information and Disclaimer:The information provided on this page represents TI's knowledge and belief as of the date that it is provided. TI bases its knowledge and belief on information provided by third parties, and makes no representation or warranty as to the accuracy of such information. Efforts are underway to better integrate information from third parties. TI has taken and continues to take reasonable steps to provide representative and accurate information but may not have conducted destructive testing or chemical analysis on incoming materials and chemicals. TI and TI suppliers consider certain information to be proprietary, and thus CAS numbers and other limited information may not be available for release.

In no event shall TI's liability arising out of such information exceed the total purchase price of the TI part(s) at issue in this document sold by TI to Customer on an annual basis.

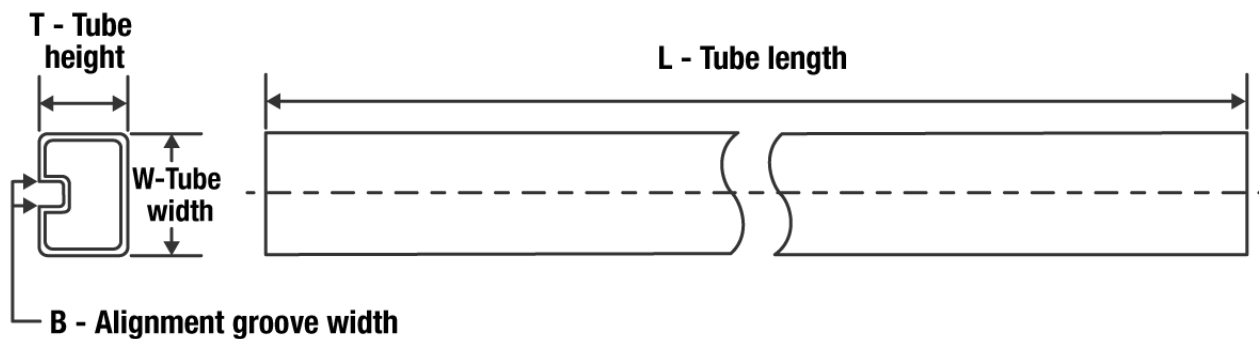
TUBE

*All dimensions are nominal

Device	Package Name	Package Type	Pins	SPQ	L (mm)	W (mm)	T (μm)	B (mm)
ADS900E	DB	SSOP	28	50	530	10.5	4000	4.1

IMPORTANT NOTICE AND DISCLAIMER

TI PROVIDES TECHNICAL AND RELIABILITY DATA (INCLUDING DATA SHEETS), DESIGN RESOURCES (INCLUDING REFERENCE DESIGNS), APPLICATION OR OTHER DESIGN ADVICE, WEB TOOLS, SAFETY INFORMATION, AND OTHER RESOURCES "AS IS" AND WITH ALL FAULTS, AND DISCLAIMS ALL WARRANTIES, EXPRESS AND IMPLIED, INCLUDING WITHOUT LIMITATION ANY IMPLIED WARRANTIES OF MERCHANTABILITY, FITNESS FOR A PARTICULAR PURPOSE OR NON-INFRINGEMENT OF THIRD PARTY INTELLECTUAL PROPERTY RIGHTS.

These resources are intended for skilled developers designing with TI products. You are solely responsible for (1) selecting the appropriate TI products for your application, (2) designing, validating and testing your application, and (3) ensuring your application meets applicable standards, and any other safety, security, regulatory or other requirements.

These resources are subject to change without notice. TI grants you permission to use these resources only for development of an application that uses the TI products described in the resource. Other reproduction and display of these resources is prohibited. No license is granted to any other TI intellectual property right or to any third party intellectual property right. TI disclaims responsibility for, and you will fully indemnify TI and its representatives against, any claims, damages, costs, losses, and liabilities arising out of your use of these resources.

TI's products are provided subject to [TI's Terms of Sale](#) or other applicable terms available either on ti.com or provided in conjunction with such TI products. TI's provision of these resources does not expand or otherwise alter TI's applicable warranties or warranty disclaimers for TI products.

TI objects to and rejects any additional or different terms you may have proposed.

Mailing Address: Texas Instruments, Post Office Box 655303, Dallas, Texas 75265
Copyright © 2022, Texas Instruments Incorporated