

# Graphic Dot Matrix Chip In Glass VFD

# MN25664G

- ❑ 256 x 64 Graphic Dot Matrix
- ❑ Chip in Glass Driver IC
- ❑ High Brightness Blue Green Display
- ❑ Synchronous Serial Interface
- ❑ Low Pinout Count
- ❑ Wide Operating Temperature

This VF glass includes a 64 bit and 2 x 256 bit serial shift register, latched drivers, which connect to the anode and grid electrodes. An external host is required to provide a multiplexing data stream to refresh the display. The signal inputs can be connected to the ports of a CMOS microprocessor. The a.c. filament supply (F1, F2) can be derived from a source of 10KHz to 200KHz. Consult our application notes for further information.

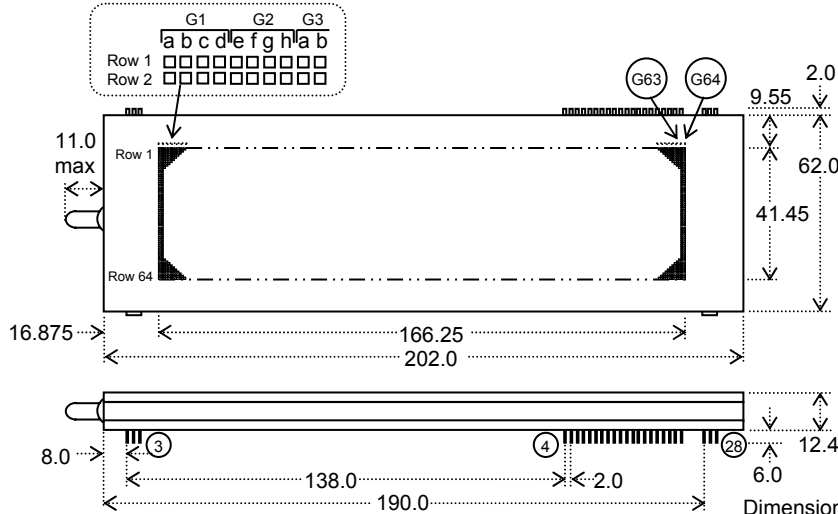

Dimensions in mm.

See full spec for tolerances

## PIN OUT

Pin	Sig	Pin	Sig
1	F1	15	GLAT
2	F1	16	GCLK
3	F1	17	GSIN
4	BLK1	18	GSOUT
5	LAT1	19	NC
6	CLK1	20	SIN2
7	SIN1	21	CLK2
8	NC	22	LAT2
9	VDD2A	23	BLK2
10	VDD2G	24	NP
11	VSS	25	NP
12	VSS	26	F2
13	VDD1	27	F2
14	GBLK	28	F2

## ELECTRICAL SPECIFICATION

Parameter	Sym	Min	Typ	Max	Unit	Condition
Logic Voltage	VDD1	4.5	5.0	5.5	V	VSS=0V
Logic Current	IDD1	-	5.0	10.0	mA	VDD1=5V
Filament Voltage	E f	6.8	7.5	8.3	Vac	VDD2=0V
Filament Current	I f	360	400	440	mAac	VDD2=0V
Display Voltage	VDD2G	46.0	56.0	58.0	V	VSS=0V
Display Voltage	VDD2A	46.0	56.0	58.0	V	VSS=0V
Display Current	IDD2G	-	17.0	35.0	mA	VDD2=50V
Display Current	IDD2A	-	25.0	50.0	mA	VDD2=60V
Filament Bias	E K	-	7.0	-	V	VSS=0V
Logic High Input	VIH	VDD1x0.8	-	VDD1	V	VSS=0V
Logic Low Input	VIL	0	-	+0.7	V	VSS=0V
Logic High Input	IiH	-	-	5.0	µA	VDD1=5V
Logic Low Input	IiL	-400	-250	-35	µA	VDD1=5V

## ENVIRONMENTAL and OPTICAL SPECIFICATION

Parameter	Value
Display Area (XxY mm)	166.25 x 41.45
Dot Size/Pitch (XxY mm)	0.5 x 0.5/0.65 x 0.65
Luminance	700 cd/m <sup>2</sup> Typ.
Colour of Illumination	Blue-Green (Filter for colours)
Operating Temperature	-40°C to +85°C
Storage Temperature	-50°C to +85°C
Operating Humidity (non condensing)	5 to 95% @ 25°C

- The power on rise time should be less than 50ms.
- The 22R resistor at the VDD2 input is required to prevent current surge during switching.
- If scanning of the display stops with VDD2 applied, the BLK input must be set high to prevent damage to the display.

## SHIFT REGISTER ASSIGNMENT

Electrode	Bit Numbers
Grid G1-G64	SIG1-64
Row 1 'abgh'	SIN1 1-4
Row 1 'fedc'	SIN2 1-4
Row 2 'abgh'	SIN1 5-8
Row 2 'fedc'	SIN2 5-8
:	:
Row 64 'abgh'	SIN1 253-256
Row 64 'fedc'	SIN2 253-256

## INTERFACE TIMING

Parameter	Time
CLK Cycle	200ns min
CLK High	80ns min
CLK Low	80ns min
SIN Setup	40ns min
SIN Hold	30ns min
LAT High	300ns min
CLK then LAT	250ns min
BLK Hold	5µs min

## INTERFACE EXAMPLE

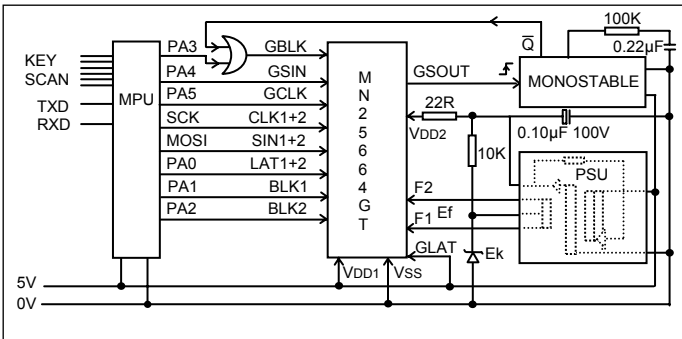

## MULTIPLEX TIMING

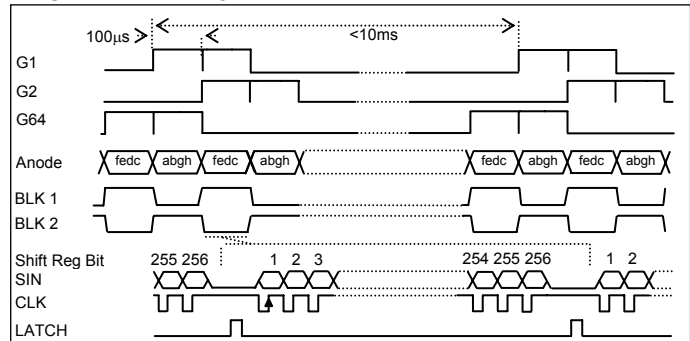

## POWER SEQUENCE

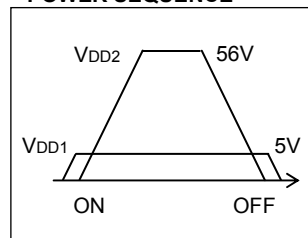

## CONTACT

**Noritake Sales Office Tel Nos**  
 Nagoya Japan: +81 (0)52-561-9867  
 Canada: +1-416-291-2946  
 Chicago USA: +1-847-439-9020  
 Munchen (D): +49 (0)89-3214-290  
 Itron UK: +44 (0)1493 601144  
 Rest Europe: +49 (0)61-0520-9220  
[www.noritake-itron.com](http://www.noritake-itron.com)  
 Subject to change without notice.  
 Doc Ref: 04821 Iss:1 4July05