

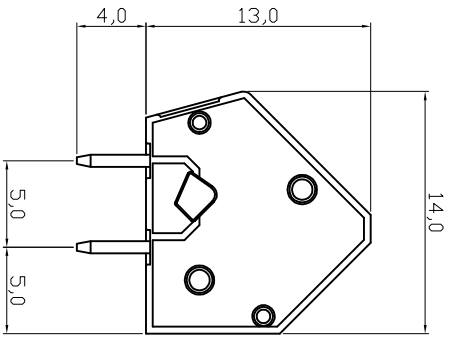

RECOMMENDED PCB LAYOUT

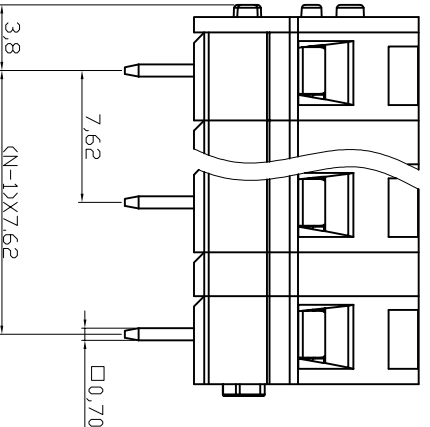

N=Number of contacts

RoHS compliant

 File No.: E349947

Scale	1:1		
TOLERANCE			
X.	±0.50		
X.X	±0.30		
X.XX	±0.10		
DIM			
X.°	±1°		
X.X°	±X°		
Angle	TOL	Id.	Modification
		②	Add the UL File No.
		①	Drawn
		Date	19.04.2016
		Name	Dean
		Date	29.07.2009
		Name	Dean
		Date	19.04.2016
		Name	Winnie

ASSMANN
 WSW/ components

Material
 Terminal body (Contact pin): Brass
 Wire guard: Stainless steel
 Surface of solder tail: Tin plated
 Insulator (housing): Thermoplastic (UL94V-0)

Electrical
 Voltage rating: 300VAC
 Current rating: 15A
 Wire range:
 Solid wire(AWG): 12-28
 Stranded wire(AWG): 12-28
 Pull force:
 Screw:
 Wire strip length: 6-7mm
 Withstanding Voltage: 1.6KV
 Operating temperature: -40°C to +115°C
 Soldering temperature: 250°C±10°C/5 Sec
 Safety approval :  us

Customer-No.
 ASSMANN WSW-No.
A-TB762-HGXX

Drawing-No.
ASS 3606 CO rev02

Replace Sheet

1	2	3	4	5	6	7	A
1	2	3	4	5	6	7	H
1	2	3	4	5	6	7	G
1	2	3	4	5	6	7	F
1	2	3	4	5	6	7	E
1	2	3	4	5	6	7	D
1	2	3	4	5	6	7	C
1	2	3	4	5	6	7	B
1	2	3	4	5	6	7	A