

## RL0816T4F-4 Series Current Sensor Resistor (Lead / Halogen Free)

### Features / Applications :

- High power rating is up to 1/2W
- Low TCR current sensor
- Resistors are ideal for all types of current sensing
- Metal film construction; Excellent long-term stability
- Moisture sensitivity level: MSL 1
- RoHS compliant

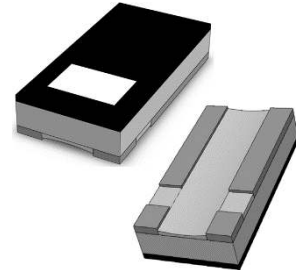

### Electrical Specifications :

Characteristics <sup>1</sup>	Feature
Power Rating <sup>2</sup>	1/2 W
Resistance Value(mΩ)	5 to 100
Temperature Coefficient of Resistance(ppm/°C)	± 150
Operation Temperature Range	-55°C to +125°C
Maximum Working Voltage (V)	( P*R) <sup>1/2</sup>

Note :

1. For detailed information see table on page 3
2. For sensors operated at ambient temperature in excess of 70°C, the maximum load shall be derated in accordance with the following curve.

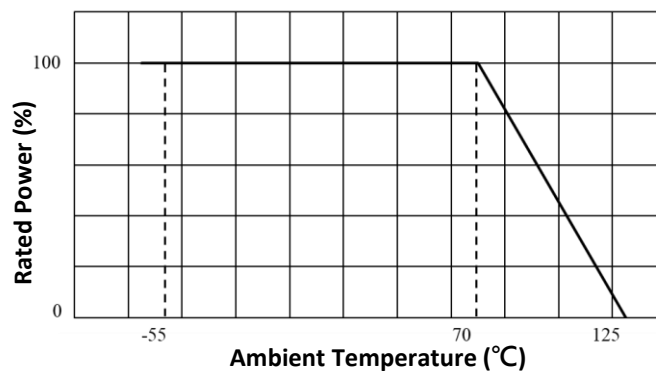
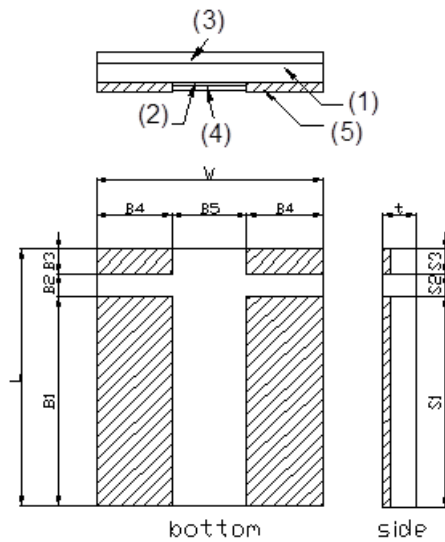

Figure 1. : Power Temperature Derating Curve

## Outline Drawing :

### Dimensions and schematic :



- (1) Substrate
- (2) Resistor : Cu alloy
- (3) Protection coat :  
Heat resistive epoxy resin (Black)
- (4) Protection coat :  
Heat resistive epoxy resin (White)
- (5) Terminals: Sn (on Cu)

Resistance Range(mΩ)	L	W	S1	S2	S3	t
5 to 100	1.60±0.20	0.80±0.15	1.10±0.20	0.25±0.10	0.25±0.10	0.50±0.20
	B1	B2	B3	B4	B5	
	1.10±0.20	0.25±0.10	0.25±0.10	0.20±0.10	0.40±0.20	

(Unit : mm)

## Type Designation :

RL 0816T4F - 4 - □□□□ - □NH

(1) (2) (3) (4) (5)

### Note :

- (1) Series No.
- (2) Size
- (3) Power Rating :4 = 1/2W
- (4) Resistance value : 0R5m = 0.5mΩ ; R002 = 2mΩ ; R010 = 10mΩ
- (5) Tolerance : ±1%(F), ±2%(G), ±3%(H) , ±5%(J)

Available standard resistance values :

Resistance Values	Tolerance			
	±0.5%	±1.0%	±2.0%	±5.0%
R005		✓	✓	✓
R006		✓	✓	✓
R007		✓	✓	✓
R008		✓	✓	✓
R009		✓	✓	✓
R010	✓	✓	✓	✓
R015		✓	✓	✓
R020		✓	✓	✓
R025	✓	✓	✓	✓
R030		✓	✓	✓
R033		✓	✓	✓
R035		✓	✓	✓
R040		✓	✓	✓
R047		✓	✓	✓
R050	✓	✓	✓	✓
R075		✓	✓	✓
R100	✓	✓	✓	✓

✓ = available

Further values and tolerances on request.

## Reliability Performance :

Test Item	Condition of Test	Requirements
Short Time Overload	2.5 x Rated power for 5 seconds Refer to JIS C 5201-1 4.13	$\Delta R : \pm 1.0\%$
Thermal Cycling	-55 to 125°C 100 cycles, 15 min at each extreme condition Refer to JIS C 5201-1 4.19	$\Delta R : \pm 1.0\%$
Low Temperature Storage	Kept at -55°C, 1000 hours Refer to JIS C 5201-1 4.23.4	$\Delta R : \pm 1.0\%$
Resistance to Soldering Heat	Dipped into solder at 260 ± 5°C for 10 ± 1 seconds Refer to JIS C 5201-1 4.18	$\Delta R : \pm 1.0\%$
Load Life	Rated voltage for 1.5hours followed by a pause 0.5hour at 70 ± 3°C Cycle repeated 1000 hours Refer to JIS C 5201-1 4.25	$\Delta R : \pm 1.0\%$
Damp Heat with Load	60 ± 2°C with relative humidity 90% to 95%. D.C. rated voltage for 1.5 hours ON and 30 minutes OFF. Cycle repeated 1,000 hours Refer to JIS C 5201-1 4.24	$\Delta R : \pm 1.0\%$
High Temperature Exposure	Kept at 125°C for 1000 hours Refer to JIS C 5201-1 4.23.2	$\Delta R : \pm 1.0\%$
Solderability	Temperature of Solder : 245 ± 5°C Immersion Duration : 3 ± 0.5 second Refer to JIS C 5201-1 4.17	Uniform coating of solder cover minimum of 95% surface being immersed
Mechanical Shock	100 G's for 6milliseconds. 5 pulses Refer to JIS C 5201-1 4.21	$\Delta R : \pm 0.5\%$
Substrate Bending	Glass-Epoxy board thickness : 1.6mm Bending width : 2mm Between the fulcrums : 90mm Refer to JIS C 5201-1 4.33	$\Delta R : \pm 0.5\%$

Note : Measurement at 24±4 hours after test conclusion for all reliability tests-parts.

## Recommend Solder Pad Dimensions :

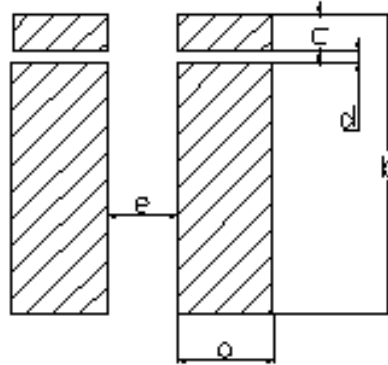

Dimensions (mm)	a	b	c	d	e
5 to 100 mΩ	0.4	1.9	0.4	0.2	0.35

## Packaging :

### Tape packaging dimensions :

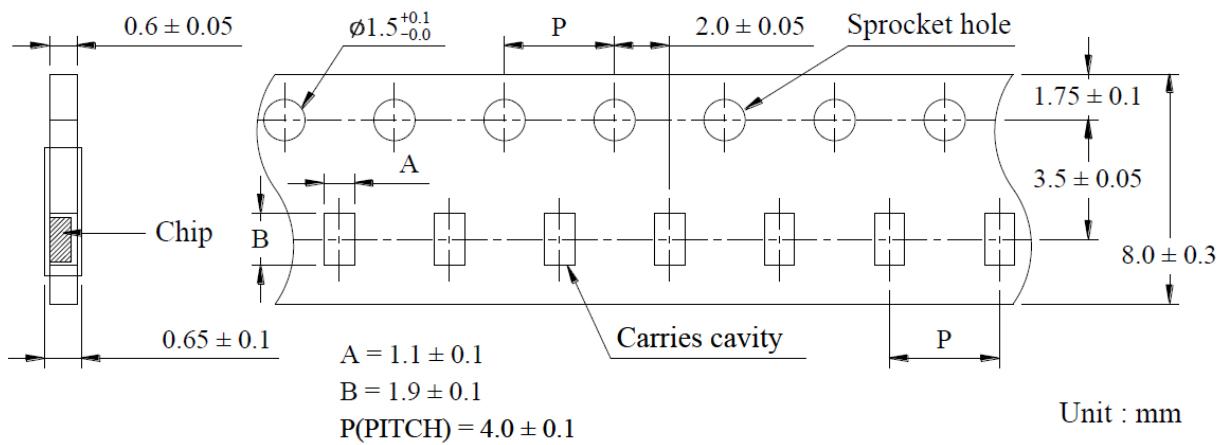

## Reel dimensions :

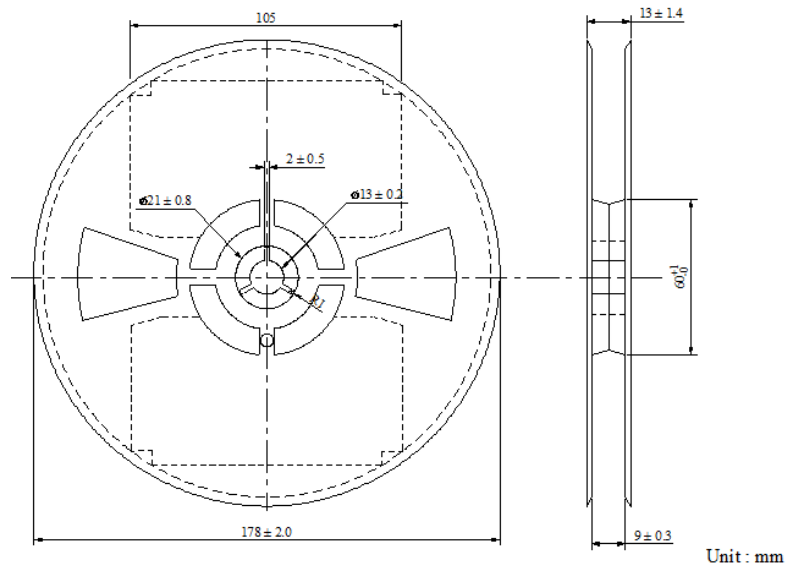

## Peel Strength of Top Cover Tape :

The peel speed shall be about 300mm/min.

The peel force of top cover tape shall between 0.1 to 0.7N

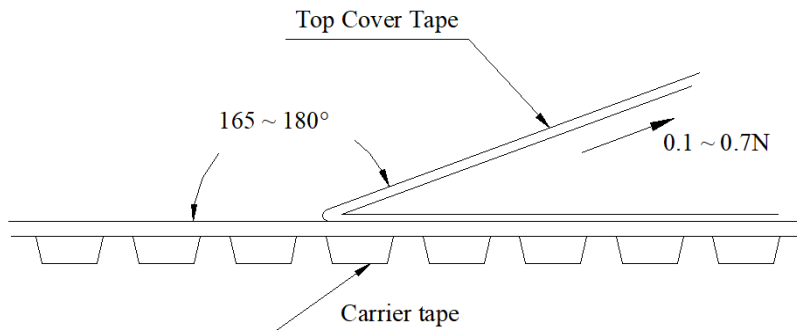

## Number of Taping :

5,000 pieces / reel

## Label Marking :

The following items shall be marked on the reel.

- (1) Type designation
- (2) Quantity
- (3) Manufacturing date code
- (4) Manufacturer's name
- (5) The country of origin

## Recommend Soldering Conditions:

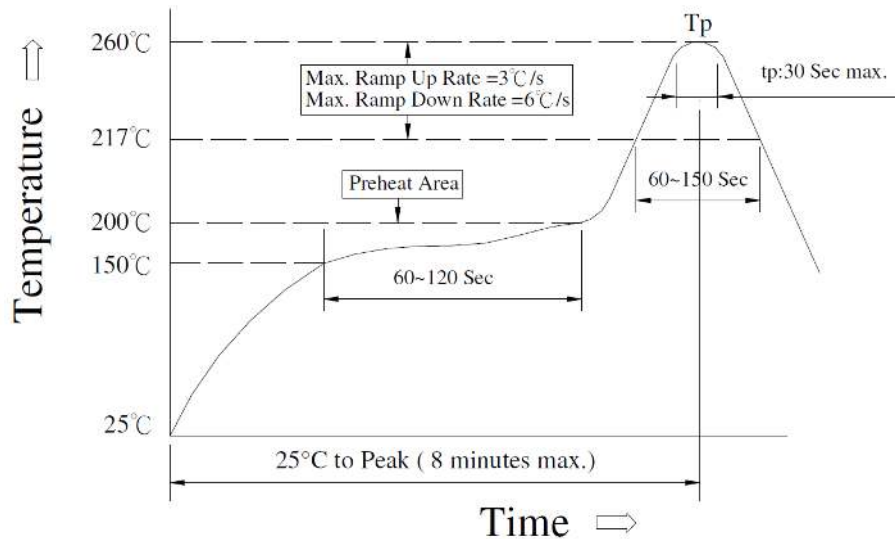

### Meet JEDEC-020D

#### (1) Reflow Soldering Method :

Reflow Soldering	Tp:255 to 260°C Max.30 seconds ( Tp )
	217°C 60 to 150 seconds
Pre-Heat	150 to 200°C 60 to 120 seconds
Time 25°C to peak temperature	8 minutes max

#### (2) Soldering Iron Method : 350± 5°C max.3 seconds

## Care Note :

### Care note for storage

- (1) Current sensor shall be stored in a environment where temperature and humidity must be controlled (temperature 5 to 40°C, humidity 30 to 80% RH) . However, the humidity should be maintained as low as possible.
- (2) Current sensor shall not be stored under direct sunlight.
- (3) Current sensor shall be stored in condition without moisture, dust, any material defect solderability, or hazardous gas (i.e. Chlorination hydrogen, sulfurous acid gas, and sulfuration hydrogen)
- (4) The sensor can be stored for at least one year under the condition mentioned above.

### Care note for operating and handling

- (1) It is necessary to protect the edge and protection coat of resistors from mechanical stress.
- (2) Handle with care when printing circuit board (PCB) is divided or fixed on support body, because bending of printing circuit board (PCB) mounting will make mechanical stress for resistors.
- (3) Resistors shall be used with in rated range shown in specification. Especially, if voltage more than specified value will be loaded to resistor, there is a case it will make damage for machine because of temperature rise depending on generating of heat, and increase resistance value or breaks.
- (4) In case that resistor is loaded a rated voltage, it is necessary to confirms temperature of a resistor and to reduce a load power according to load reduction curve, because a temperature rise of a resistor depends on influence of heat from mounting density and neighboring element.
- (5) Observe Limiting element voltage and maximum overload voltage specified in each specification
- (6) If there is possibility that a large voltage (pulse voltage, shock voltage) charge to resistor, it is necessary that operating condition shall be set up before use.