

HD74LS190

Synchronous Up / Down Decade Counter (signal clock line)

REJ03D0452-0200

Rev.2.00

Jul.15.2005

Synchronous operation is provided by having all flip-flops clocked simultaneously so that the outputs change coincident with each other when so instructed by the steering logic. This mode of operation eliminates the output counting spikes normally associated with asynchronous (ripple clock) counters.

The outputs of the four master-slave flip-flops are triggered on a low-to-high-level transition of the clock input if the enable input is low. A high at the enable input inhibits counting. Level changes at the enable input should be made only when the clock input is high. The direction of the count is determined by the level of the down / up input. When low, the counter counts up and when high, it counts down. Level changes at the down / up input should be made only when the clock input is high. This counter is fully programmable; that is, the outputs may be preset to either level by placing a low on the load input and entering the desired data at the data inputs. The output will change to agree with the data inputs independently of the level of the clock input. This feature allows the counters to be used as modulo-N dividers by simply modifying the count length with the preset inputs. The clock, down / up, and load inputs are buffered to lower the drive requirement which significantly reduces the number of clock drivers, etc., required for long parallel words.

Two outputs have been made available to perform the cascading function: ripple clock and maximum / minimum count. The latter output produces a high-level output pulse with a duration approximately equal to one complete cycles to the clock when the counter overflows or underflows. The ripple clock output produces a low-level output pulse equal in width to the low-level portion of the clock input when an overflow or underflow conditions exists.

The counters can be easily cascaded by feeding the ripple clock output to the enable input of the succeeding counter if parallel clocking is used, or to the clock input if parallel enabling is used. The maximum / minimum count output can be used to accomplish look-ahead for high-speed operation.

Features

- Ordering Information

Part Name	Package Type	Package Code (Previous Code)	Package Abbreviation	Taping Abbreviation (Quantity)
HD74LS190P	DILP-16 pin	PRDP0016AE-B (DP-16FV)	P	—
HD74LS190FPEL	SOP-16 pin (JEITA)	PRSP0016DH-B (FP-16DAV)	FP	EL (2,000 pcs/reel)

Notes: Please consult the sales office for the above package availability.

Pin Arrangement

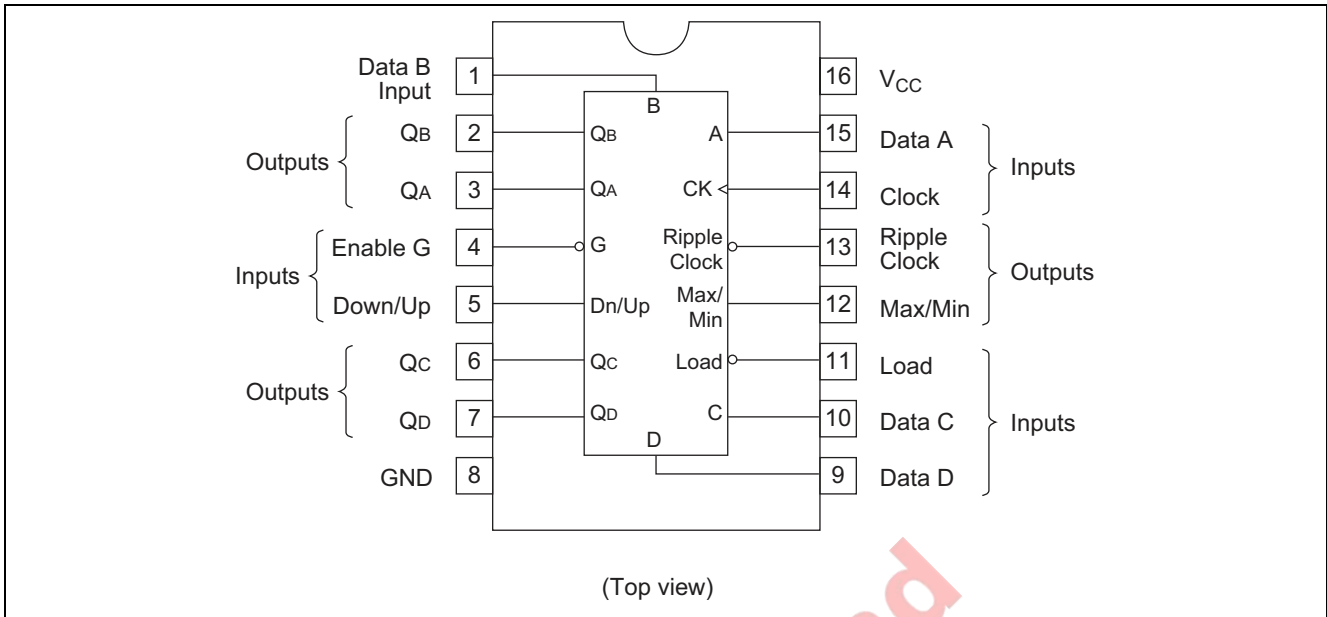

Not recommend
for new design

Block Diagram

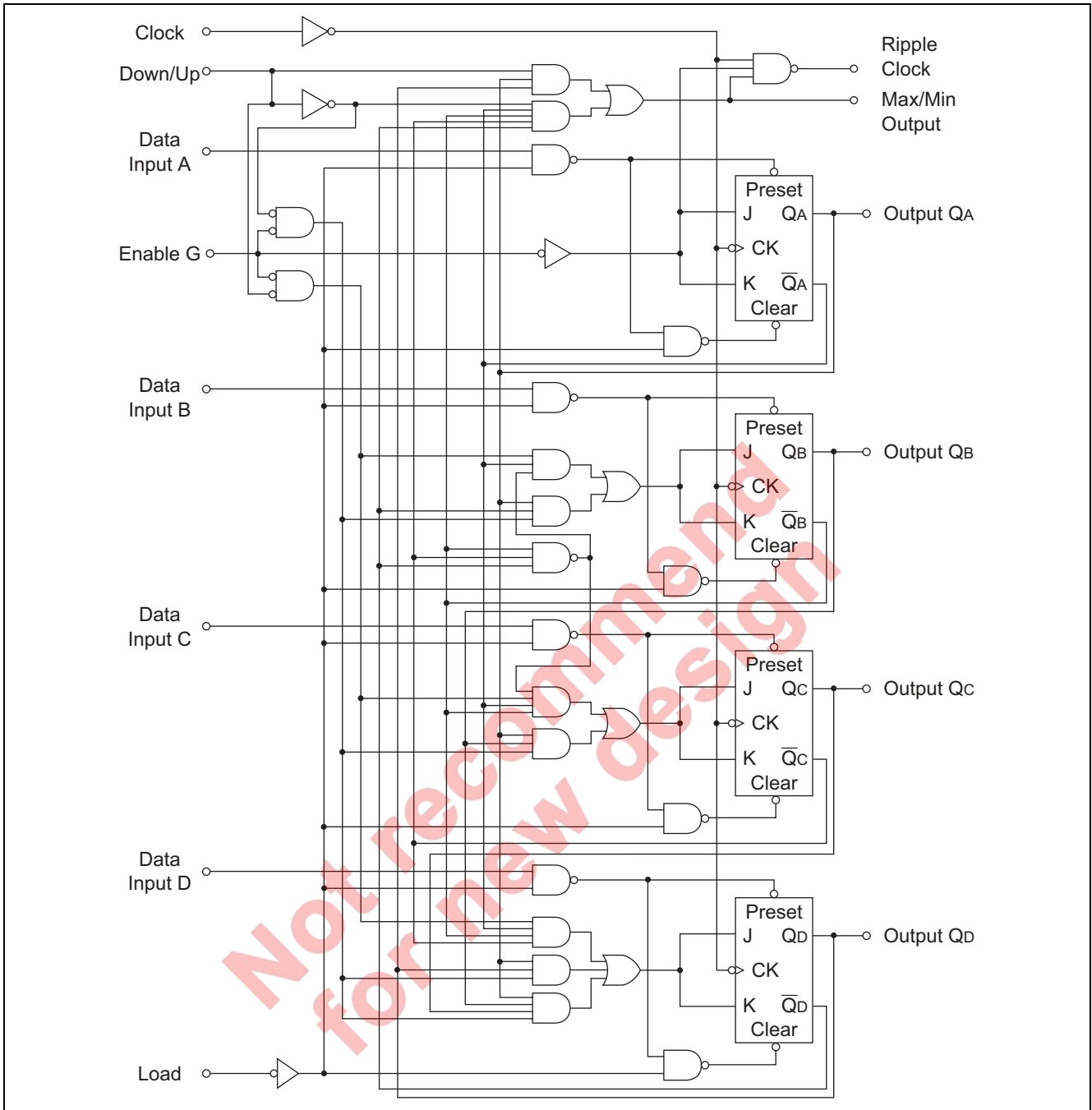

Absolute Maximum Ratings

Item	Symbol	Ratings	Unit
Supply voltage	V_{CC}	7	V
Input voltage	V_{IN}	7	V
Power dissipation	P_T	400	mW
Storage temperature	Tstg	-65 to +150	°C

Note: Voltage value, unless otherwise noted, are with respect to network ground terminal.

Recommended Operating Conditions

Item	Symbol	Min	Typ	Max	Unit
Supply voltage	V_{CC}	4.75	5.00	5.25	V
Output current	I_{OH}	—	—	-400	∞ A
	I_{OL}	—	—	8	mA
Operating temperature	T_{opr}	-20	25	75	$^{\circ}$ C
Clock frequency	f_{clock}	0	—	20	MHz
Clock pulse width	$t_w(CK)$	25	—	—	ns
Load pulse width	$t_w(Load)$	35	—	—	ns
Setup time	t_{su}	20	—	—	ns
Hold time	$t_h(data)$	3	—	—	ns
Enable time	t_{enable}	40	—	—	ns

Electrical Characteristics

($T_a = -20$ to $+75$ $^{\circ}$ C)

Item	Symbol	min.	typ.*	max.	Unit	Condition
Input voltage	V_{IH}	2.0	—	—	V	
	V_{IL}	—	—	0.8	V	
Output voltage	V_{OH}	2.7	—	—	V	$V_{CC} = 4.75$ V, $V_{IH} = 2$ V, $V_{IL} = 0.8$ V, $I_{OH} = -400$ ∞ A
	V_{OL}	—	—	0.4	V	$I_{OL} = 4$ mA
—		—	0.5	$I_{OL} = 8$ mA		
Input current	Enable	—	—	60	∞ A	$V_{CC} = 5.25$ V, $V_I = 2.7$ V
	Others			20		
	Enable	—	—	-1.2	mA	
	Others			-0.4		
	Enable	—	—	0.3	mA	
Others	0.1					
Short-circuit output current	I_{OS}	-20	—	-100	mA	$V_{CC} = 5.25$ V
Supply current**	I_{CC}	—	20	35	mA	$V_{CC} = 5.25$ V
Input clamp voltage	V_{IK}	—	—	-1.5	V	$V_{CC} = 4.75$ V, $I_{IN} = -18$ mA

Notes: * $V_{CC} = 5$ V, $T_a = 25^{\circ}$ C

** I_{CC} is measured with all outputs open and all inputs grounded.

Switching Characteristics

($V_{CC} = 5\text{ V}$, $T_a = 25^\circ\text{C}$)

Item	Symbol	Inputs	Outputs	min.	typ.	max.	Unit	Condition
Maximum clock frequency	f_{max}	Clock	Q_A, Q_B, Q_C, Q_D	20	25	—	MHz	$C_L = 15\text{ pF}$, $R_L = 2\text{ k}\Omega$
Propagation delay time	t_{PLH}	Load	Q_A, Q_B, Q_C, Q_D	—	22	33	ns	
	t_{PHL}			—	33	50		
	t_{PLH}	A, B, C, D	Q_A, Q_B, Q_C, Q_D	—	20	32	ns	
	t_{PHL}			—	27	40		
	t_{PLH}	Clock	Ripple Clock	—	13	20	ns	
	t_{PHL}			—	16	24		
	t_{PLH}	Clock	Q_A, Q_B, Q_C, Q_D	—	16	24	ns	
	t_{PHL}			—	24	36		
	t_{PLH}	Clock	Max / Min	—	28	42	ns	
	t_{PHL}			—	37	52		
	t_{PLH}	Down / Up	Ripple Clock	—	30	45	ns	
	t_{PHL}			—	30	45		
	t_{PLH}	Down / Up	Max / Min	—	21	33	ns	
	t_{PHL}			—	22	33		
	t_{PLH}	Enable	Ripple Clock	—	21	33	ns	
	t_{PHL}			—	22	33		

Not recommended for new design

Count Sequences

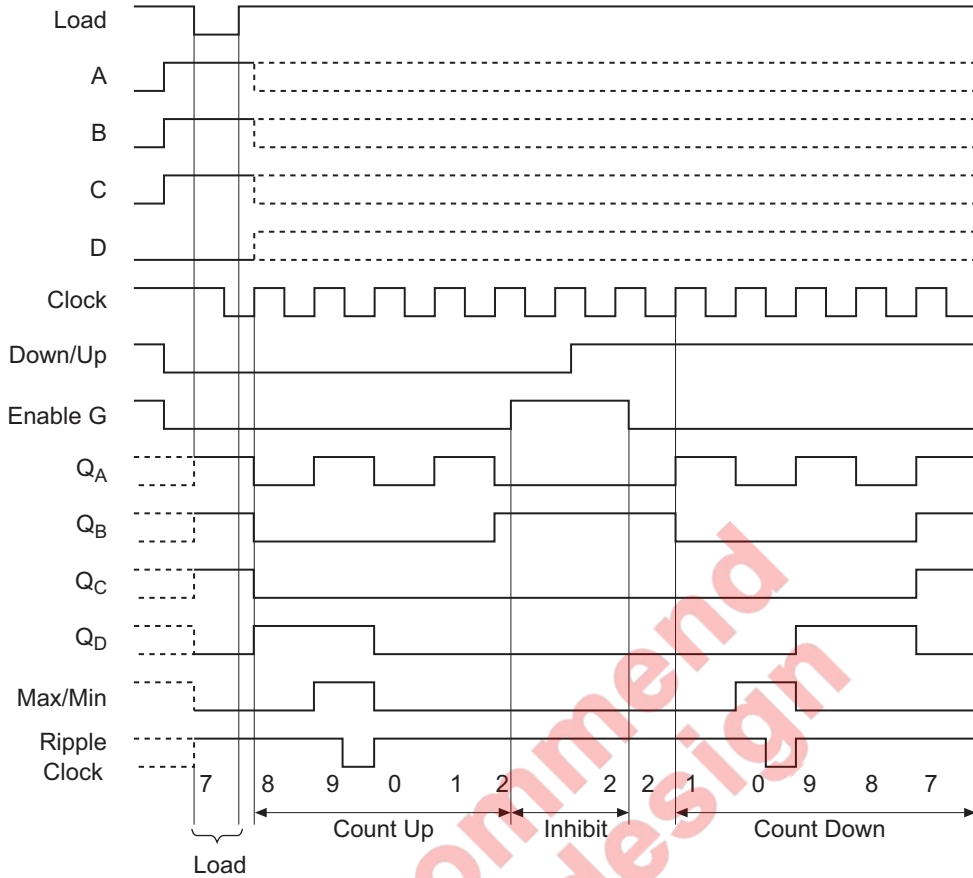

Illustrated below is the following sequence:

1. Load (preset) to BCD seven.
2. Count up to eight, nine (maximum), zero, one and two.
3. Inhibit
4. Count down to one, zero (minimum), nine, eight, and seven.

Testing Method

Test Circuit

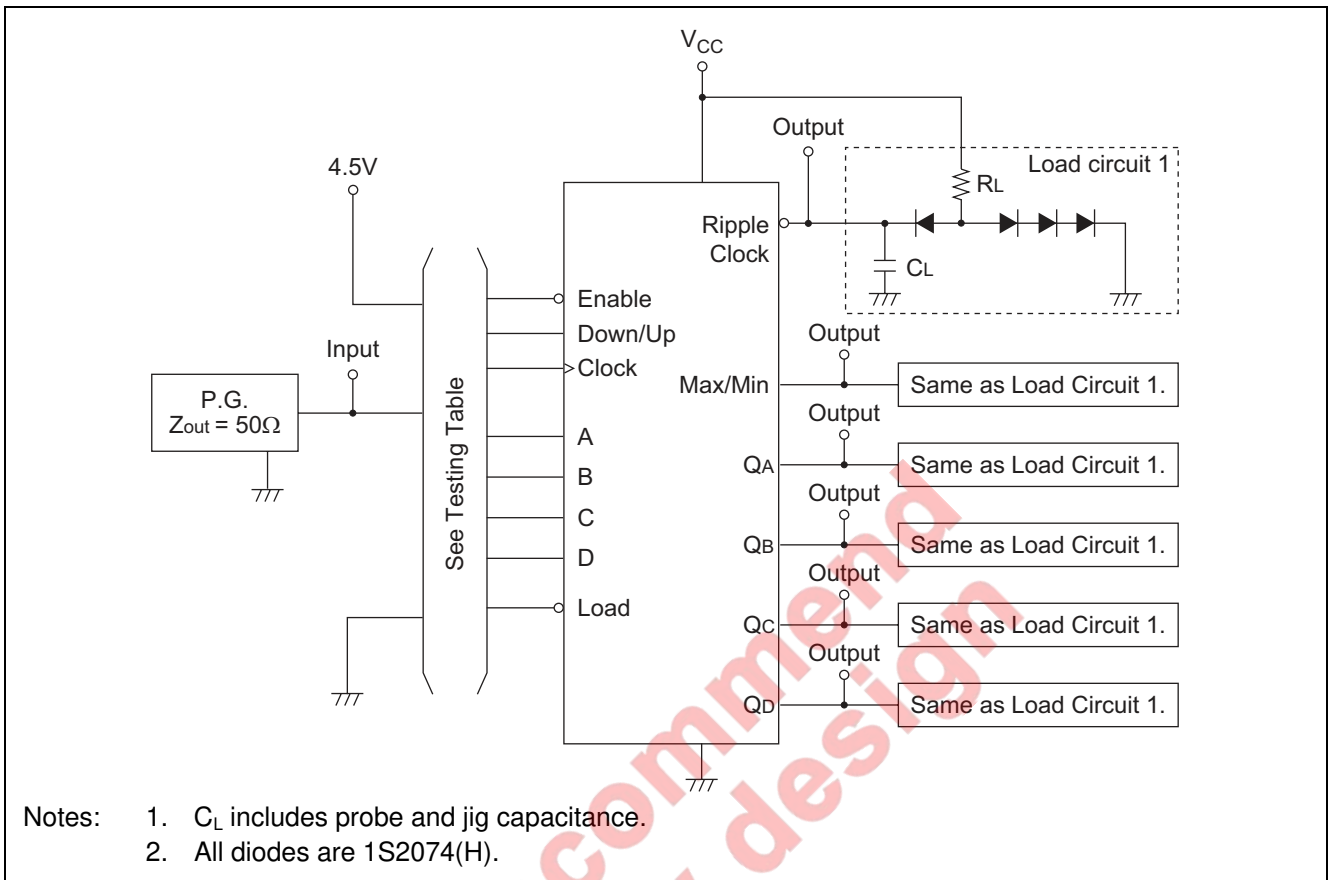

Waveforms 1

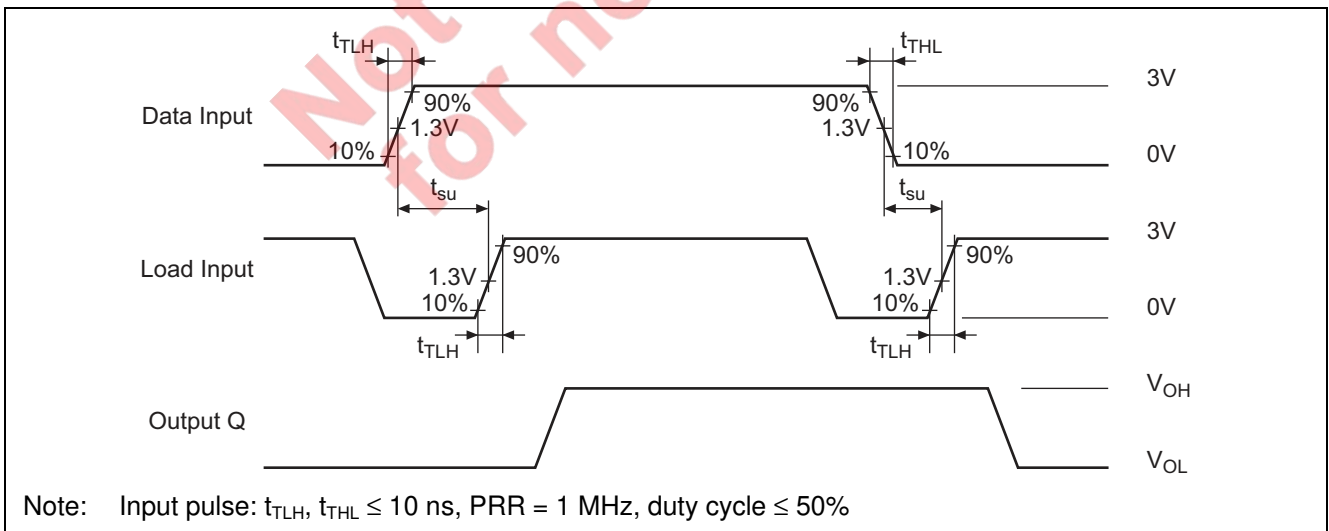

Waveforms 2

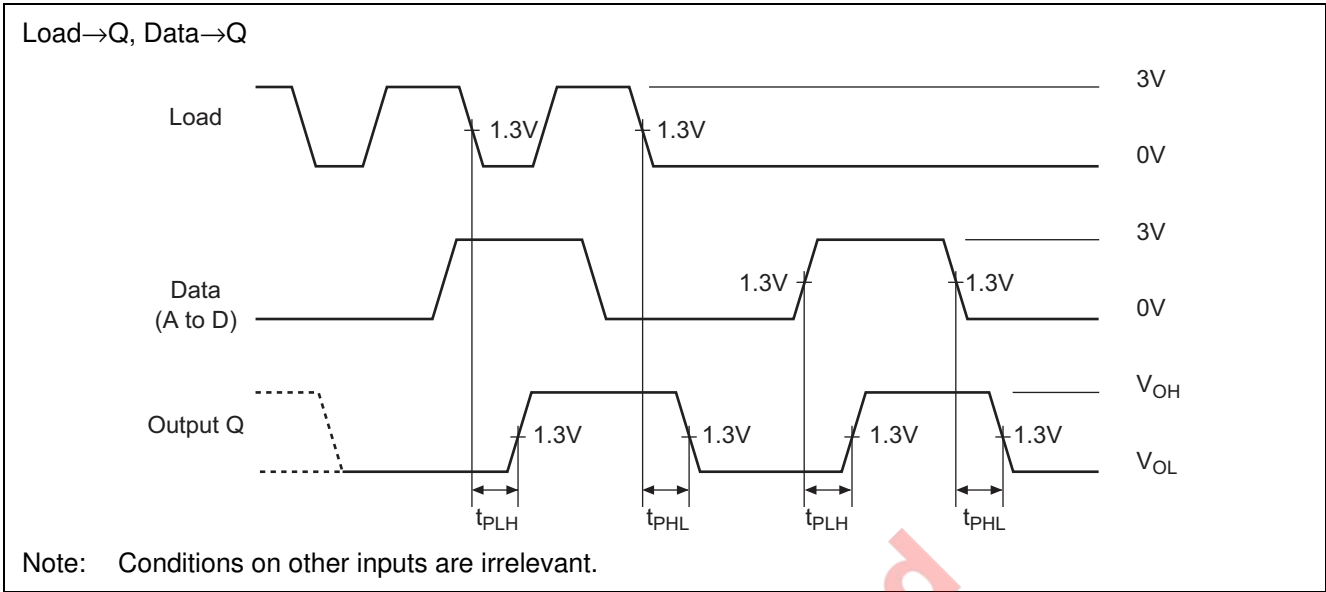

Waveforms 3

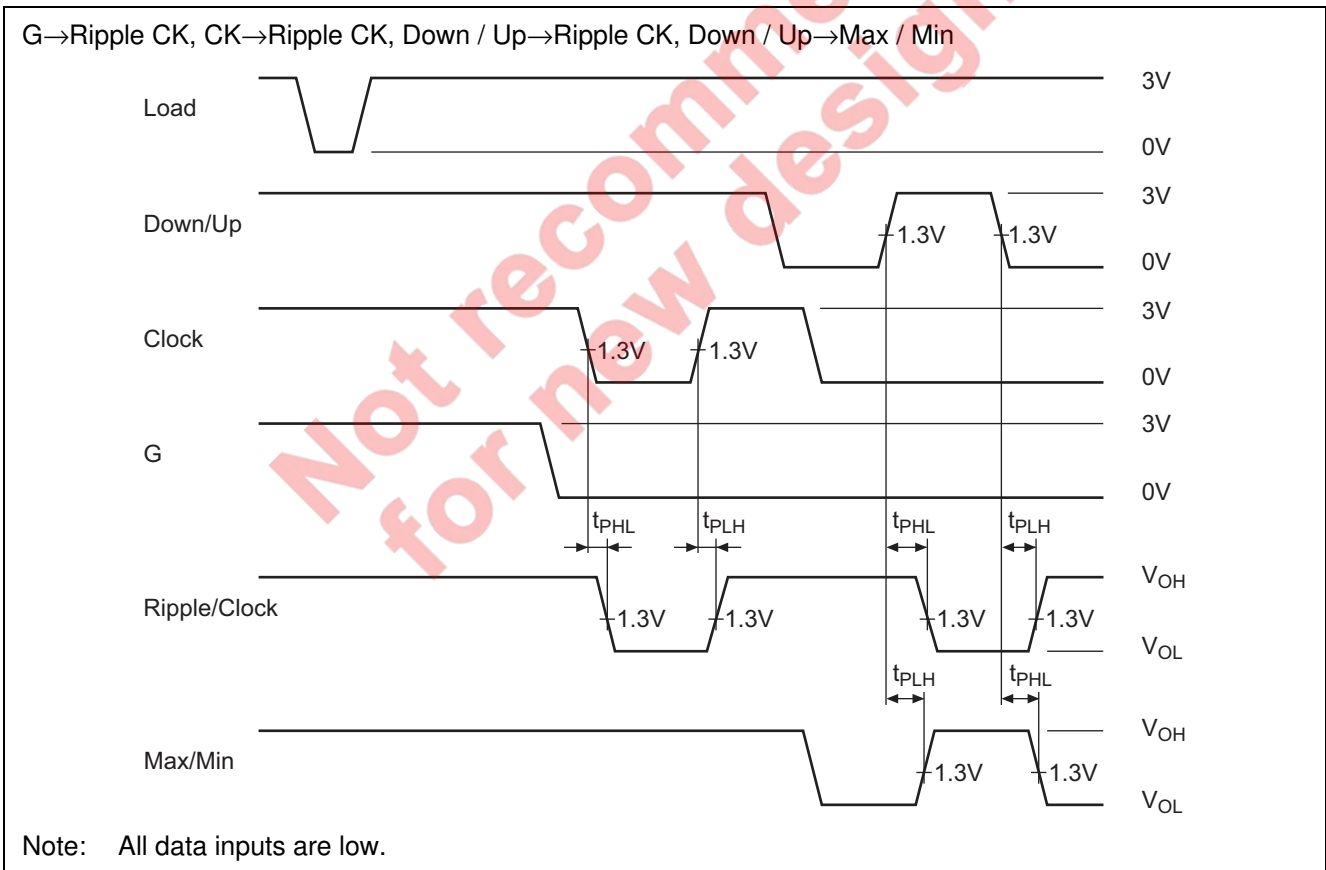

Waveforms 4

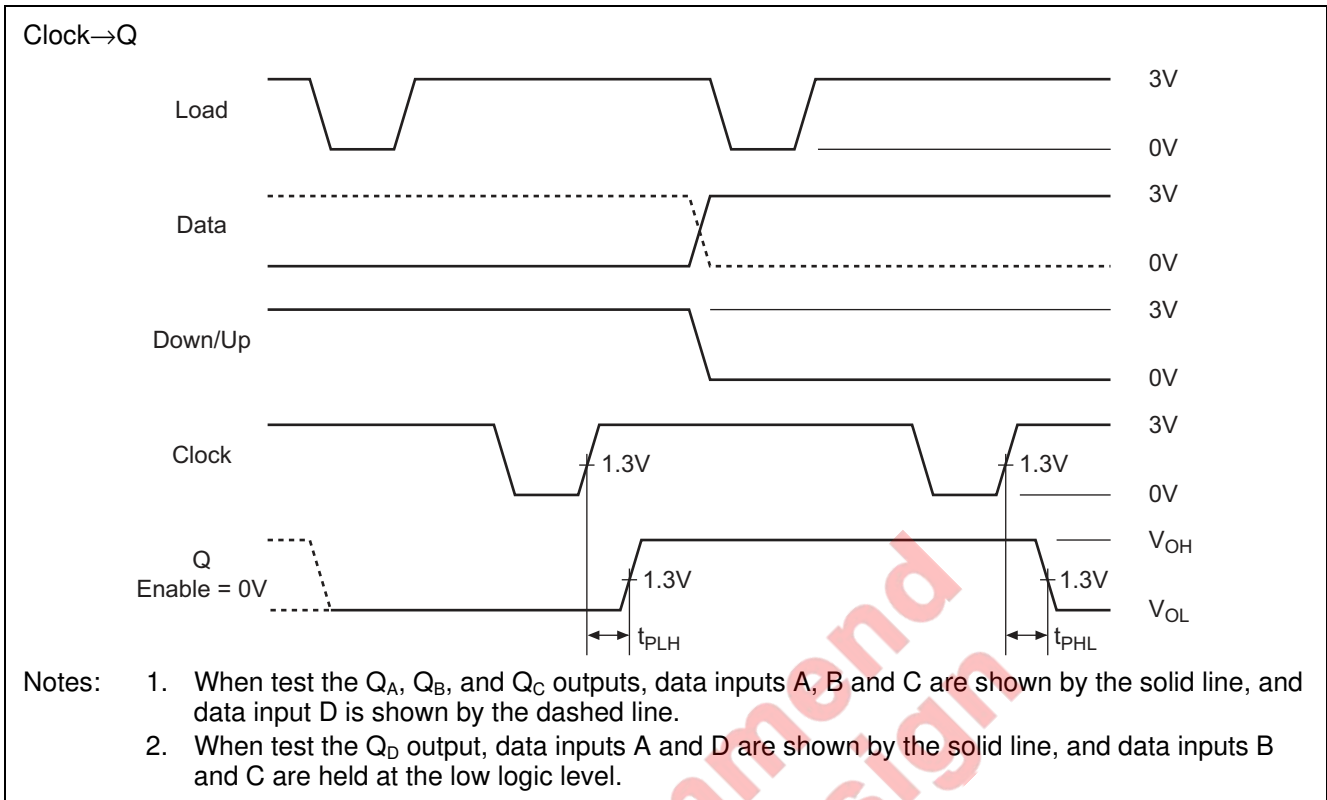

Waveforms 5

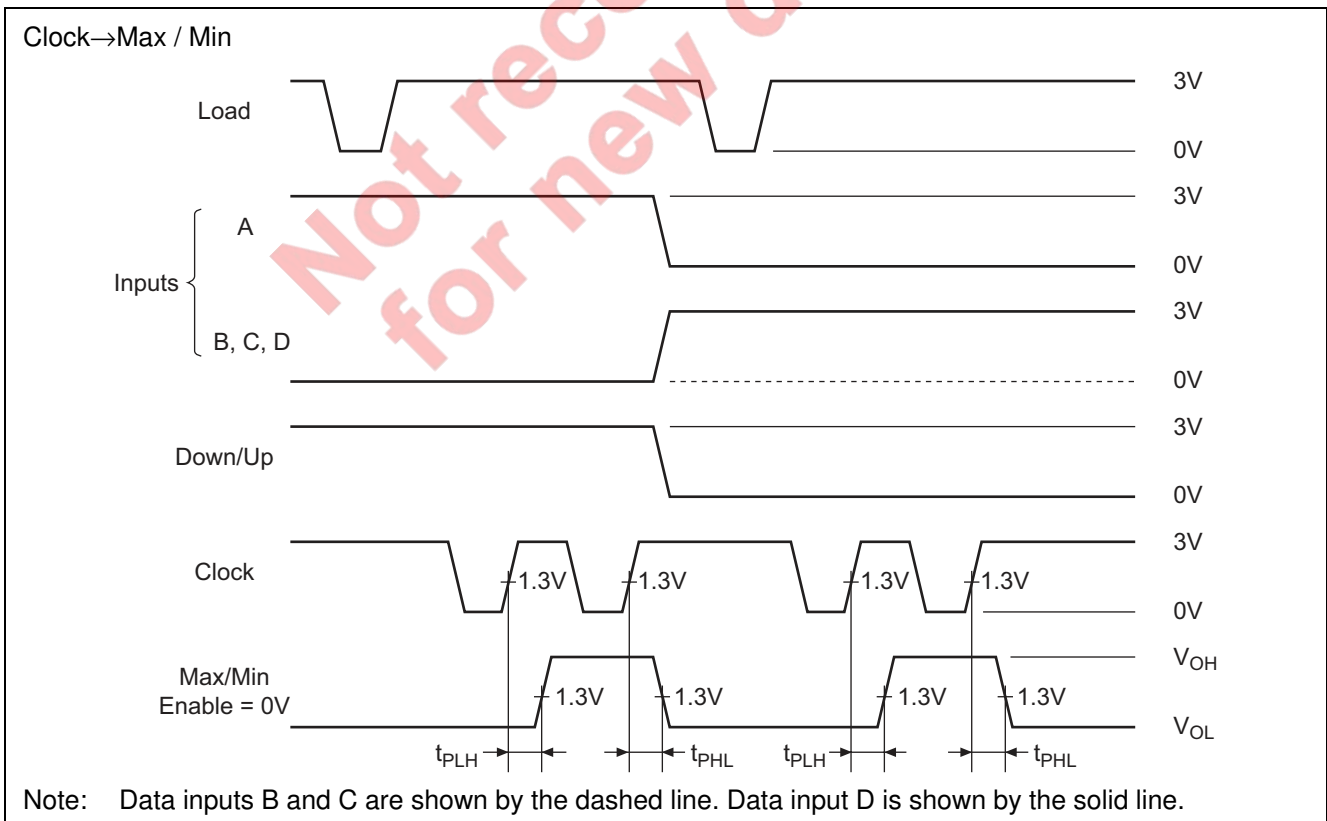

Package Dimensions

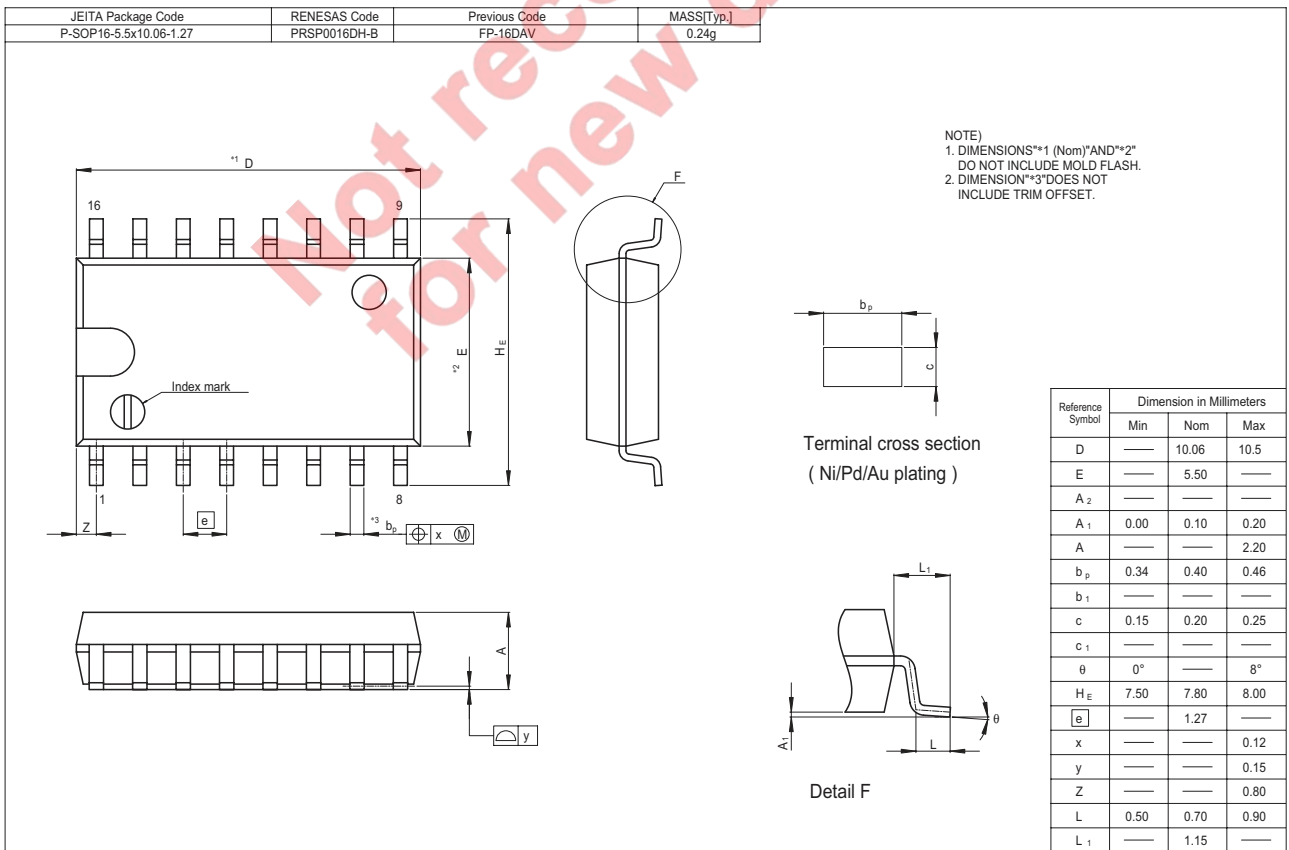
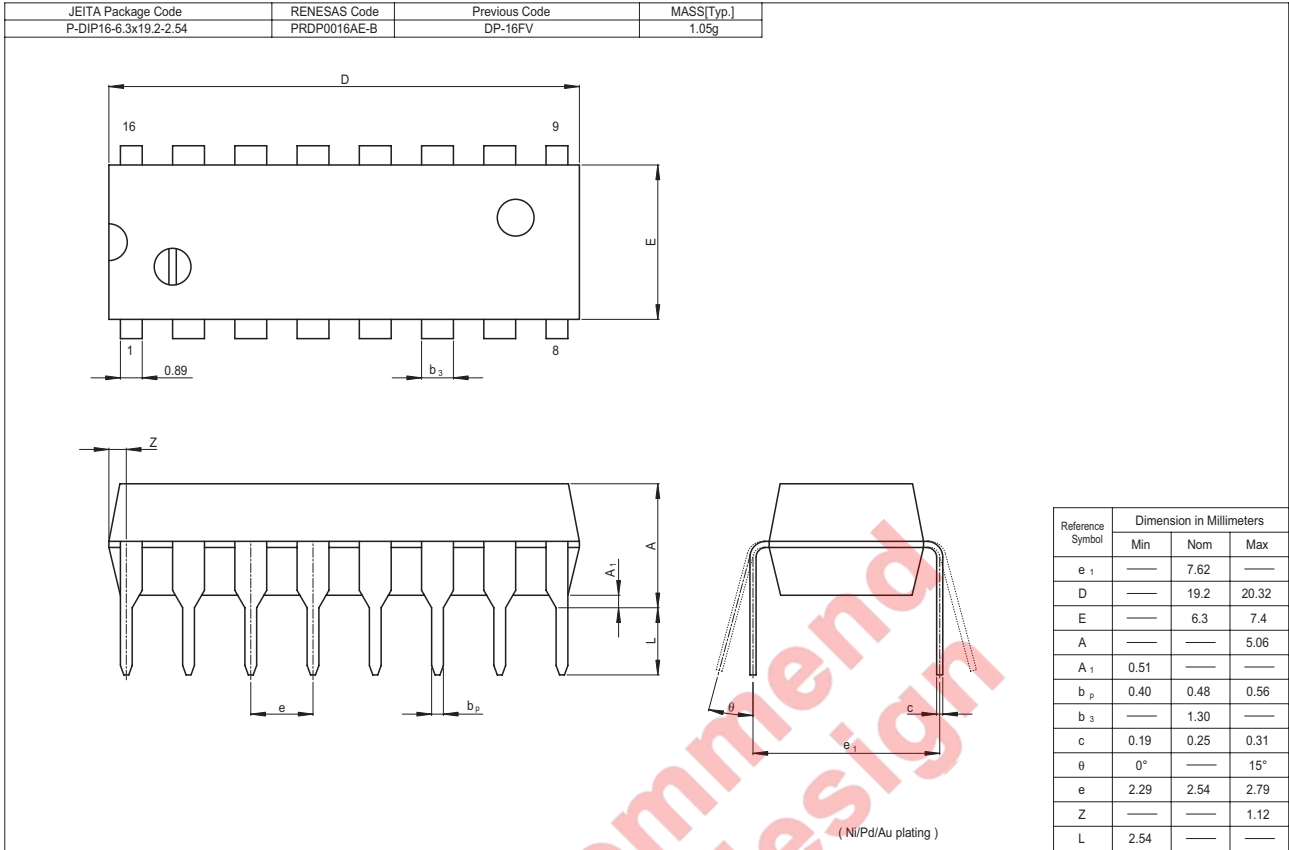

Renesas Technology Corp. Sales Strategic Planning Div. Nippon Bldg., 2-6-2, Ohte-machi, Chiyoda-ku, Tokyo 100-0004, Japan

Keep safety first in your circuit designs!

1. Renesas Technology Corp. puts the maximum effort into making semiconductor products better and more reliable, but there is always the possibility that trouble may occur with them. Trouble with semiconductors may lead to personal injury, fire or property damage. Remember to give due consideration to safety when making your circuit designs, with appropriate measures such as (i) placement of substitutive, auxiliary circuits, (ii) use of nonflammable material or (iii) prevention against any malfunction or mishap.

Notes regarding these materials

1. These materials are intended as a reference to assist our customers in the selection of the Renesas Technology Corp. product best suited to the customer's application; they do not convey any license under any intellectual property rights, or any other rights, belonging to Renesas Technology Corp. or a third party.
2. Renesas Technology Corp. assumes no responsibility for any damage, or infringement of any third-party's rights, originating in the use of any product data, diagrams, charts, programs, algorithms, or circuit application examples contained in these materials.
3. All information contained in these materials, including product data, diagrams, charts, programs and algorithms represents information on products at the time of publication of these materials, and are subject to change by Renesas Technology Corp. without notice due to product improvements or other reasons. It is therefore recommended that customers contact Renesas Technology Corp. or an authorized Renesas Technology Corp. product distributor for the latest product information before purchasing a product listed herein.
The information described here may contain technical inaccuracies or typographical errors.
Renesas Technology Corp. assumes no responsibility for any damage, liability, or other loss rising from these inaccuracies or errors.
Please also pay attention to information published by Renesas Technology Corp. by various means, including the Renesas Technology Corp. Semiconductor home page (<http://www.renesas.com>).
4. When using any or all of the information contained in these materials, including product data, diagrams, charts, programs, and algorithms, please be sure to evaluate all information as a total system before making a final decision on the applicability of the information and products. Renesas Technology Corp. assumes no responsibility for any damage, liability or other loss resulting from the information contained herein.
5. Renesas Technology Corp. semiconductors are not designed or manufactured for use in a device or system that is used under circumstances in which human life is potentially at stake. Please contact Renesas Technology Corp. or an authorized Renesas Technology Corp. product distributor when considering the use of a product contained herein for any specific purposes, such as apparatus or systems for transportation, vehicular, medical, aerospace, nuclear, or undersea repeater use.
6. The prior written approval of Renesas Technology Corp. is necessary to reprint or reproduce in whole or in part these materials.
7. If these products or technologies are subject to the Japanese export control restrictions, they must be exported under a license from the Japanese government and cannot be imported into a country other than the approved destination.
Any diversion or reexport contrary to the export control laws and regulations of Japan and/or the country of destination is prohibited.
8. Please contact Renesas Technology Corp. for further details on these materials or the products contained therein.



RENESAS SALES OFFICES

<http://www.renesas.com>

Refer to "<http://www.renesas.com/en/network>" for the latest and detailed information.

Renesas Technology America, Inc.

450 Holger Way, San Jose, CA 95134-1368, U.S.A
Tel: <1> (408) 382-7500, Fax: <1> (408) 382-7501

Renesas Technology Europe Limited

Dukes Meadow, Millboard Road, Bourne End, Buckinghamshire, SL8 5FH, U.K.
Tel: <44> (1628) 585-100, Fax: <44> (1628) 585-900

Renesas Technology Hong Kong Ltd.

7th Floor, North Tower, World Finance Centre, Harbour City, 1 Canton Road, Tsimshatsui, Kowloon, Hong Kong
Tel: <852> 2265-6688, Fax: <852> 2730-6071

Renesas Technology Taiwan Co., Ltd.

10th Floor, No.99, Fushing North Road, Taipei, Taiwan
Tel: <886> (2) 2715-2888, Fax: <886> (2) 2713-2999

Renesas Technology (Shanghai) Co., Ltd.

Unit2607 Ruijing Building, No.205 Maoming Road (S), Shanghai 200020, China
Tel: <86> (21) 6472-1001, Fax: <86> (21) 6415-2952

Renesas Technology Singapore Pte. Ltd.

1 Harbour Front Avenue, #06-10, Keppel Bay Tower, Singapore 098632
Tel: <65> 6213-0200, Fax: <65> 6278-8001

Renesas Technology Korea Co., Ltd.

Kukje Center Bldg. 18th Fl., 191, 2-ka, Hangang-ro, Yongsan-ku, Seoul 140-702, Korea
Tel: <82> 2-796-3115, Fax: <82> 2-796-2145

Renesas Technology Malaysia Sdn. Bhd.

Unit 906, Block B, Menara Amcorp, Amcorp Trade Centre, No.18, Jalan Persiaran Barat, 46050 Petaling Jaya, Selangor Darul Ehsan, Malaysia
Tel: <603> 7955-9390, Fax: <603> 7955-9510