

General Description

The AOZ8206 is a transient voltage suppressor diode array designed to protect data lines from high transient conditions and ESD. This state-of-the-art device utilizes AOS leading edge Trench Vertical Structure [TVS]²™ technology for superior clamping performance.

This device incorporates six TVS diodes in a single package. During transient conditions, the TVS diodes direct the transient to ground. They may be used to meet the ESD immunity requirements of IEC 61000-4-2, Level 4 (±15kV air, ±8kV contact discharge).

The AOZ8206 is RoHS compliant. The DFN-6 package is rated over a -40°C to +85°C ambient temperature range.

The very small DFN-6 1.6 x 1.6 x 0.55mm package makes it ideal for applications where PCB space is a premium. The small size and high ESD protection makes it ideal for protecting high speed video and data communication interfaces.

Features

- ESD protection for high-speed data lines:
 - Exceeds: IEC 61000-4-2 (ESD) ±20kV (air), ±20kV (contact)
 - Human Body Model (HBM) ±20kV
- Trench Vertical Structure [TVS]²™ based technology used to achieve excellent ESD clamping performance
- Small package saves board space
- Low insertion loss
- Protects six unidirectional I/O lines
- Low clamping voltage
- Low operating voltage: 5.0V
- Green product, Pb-free

Applications

- Portable handheld devices
- Keypads, data lines
- Notebook computers
- Digital Cameras
- Portable GPS
- MP3 players



Typical Applications

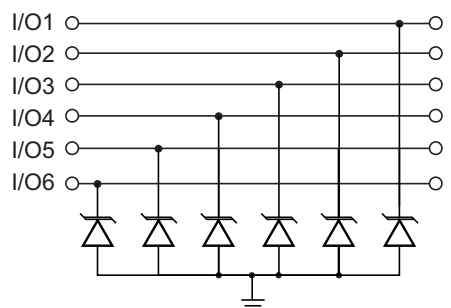

Unidirection Protection of Six Lines

Pin Configuration

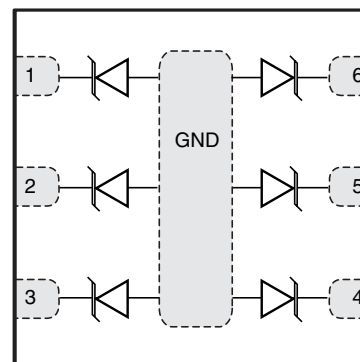

Top View

Ordering Information

Part Number	Ambient Temperature Range	Package	Environmental
AOZ8206DI-05	-40°C to +85°C	DFN 1.6x1.6_6L	Green Product RoHS Compliant



AOS Green Products use reduced levels of Halogens, and are also RoHS compliant.
Please visit www.aosmd.com/web/quality/rohs_compliant.jsp for additional information.

Absolute Maximum Ratings

Exceeding the Absolute Maximum ratings may damage the device.

Parameter	Rating
Peak Pulse Current (I_{PP}), $t_P = 8/20\mu s$	5A
Storage Temperature (T_S)	-65°C to +150°C
ESD Rating per IEC61000-4-2, Contact ⁽¹⁾	±20kV
ESD Rating per IEC61000-4-2, Air ⁽¹⁾	±20kV
ESD Rating per Human Body Model ⁽²⁾	±20kV

Notes:

- IEC 61000-4-2 discharge with $C_{Discharge} = 150pF$, $R_{Discharge} = 330\Omega$.
- Human Body Discharge per MIL-STD-883, Method 3015 $C_{Discharge} = 100pF$, $R_{Discharge} = 1.5k\Omega$.

Maximum Operating Ratings

Parameter	Rating
Junction Temperature (T_J)	-40°C to +125°C

Electrical Characteristics

$T_A = 25^\circ C$ unless otherwise specified.

Symbol	Parameter	Diagram
I_{PP}	Maximum Reverse Peak Pulse Current	
V_{CL}	Clamping Voltage @ I_{PP}	
V_{RWM}	Working Peak Reverse Voltage	
I_R	Maximum Reverse Leakage Current	
V_{BR}	Breakdown Voltage	
I_F	Forward Current	
V_F	Forward Voltage	
P_{PK}	Peak Power Dissipation	
C_J	Max. Capacitance @ $V_R = 0$ and $f = 1MHz$	

Device	Device Marking	V_{RWM} (V) Max.	V_{BR} (V) Min.	I_R (μA) Max.	V_F (V) Typ.	V_{CL} Max.			C_J (pF) Max.
						$I_{PP} = 1A$	$I_{PP} = 5A$	$I_{PP} = 12A$	
AOZ8206DI-05	C	5	6.0	0.1	0.85	7.0	8.0	9.0	17

Typical Performance Characteristics

Typical Variation of C_{IN} vs. V_R
($f = 1\text{MHz}$, $T = 25^\circ\text{C}$)

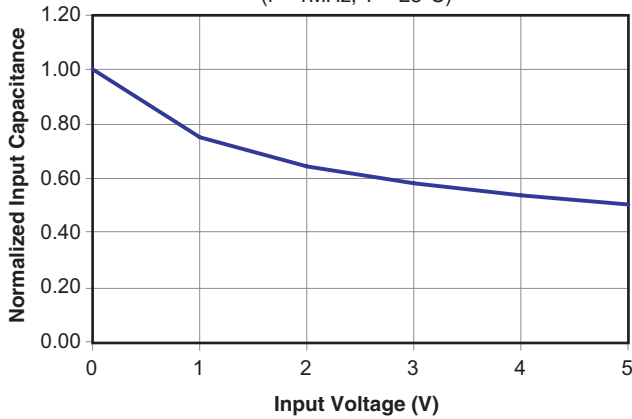

Clamping Voltage vs. Peak Pulse Current
($t_{\text{period}} = 100\text{ns}$, $t_r = 1\text{ns}$)

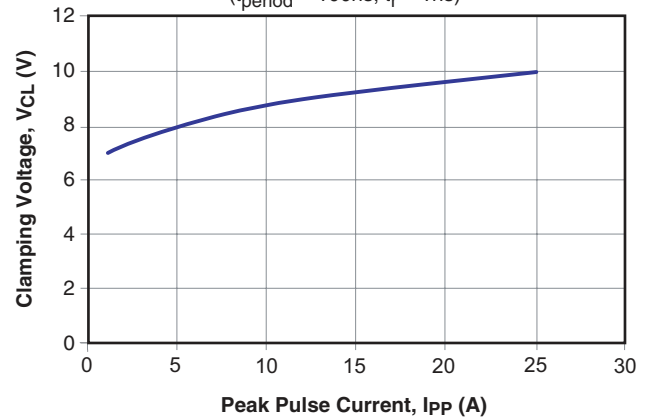

Forward Voltage vs. Forward Current
($t_{\text{period}} = 100\text{ns}$, $t_r = 1\text{ns}$)

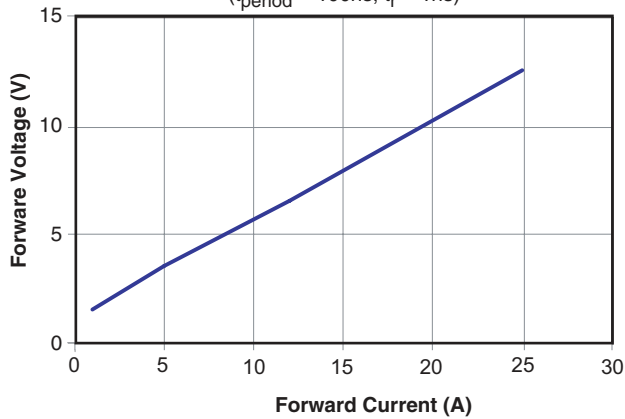

I/O – Gnd Insertion Loss (S21) vs. Frequency

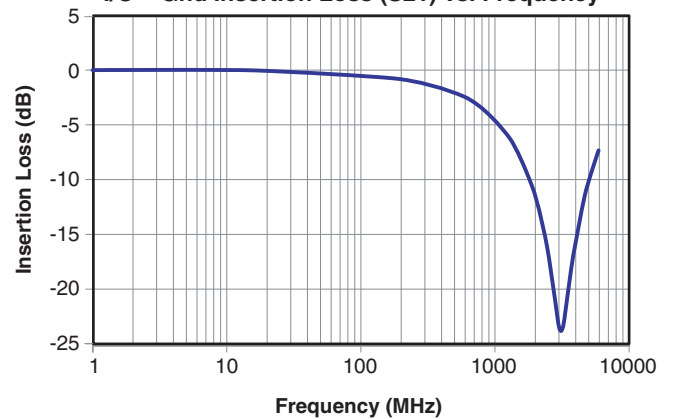

Crosstalk (I/O-I/O) vs. Frequency

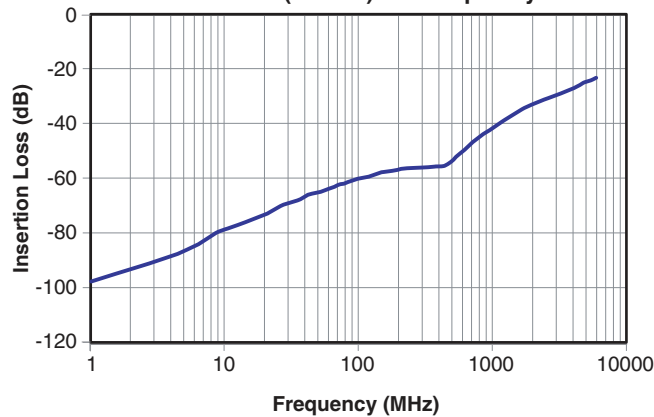

Applications Information

Device Connection for Protection of Six Unidirectional Data Lines

These devices are designed to protect up to six unidirectional data lines. The device is connected as follows.

- Unidirectional protection of six I/O lines is achieved by connecting pins 1, 2, 3, 4, 5 and 6 to the data lines. The ground connection should be made directly to the ground plane for best results. The path length is kept as short as possible to reduce the effects of parasitic inductance in the board traces.

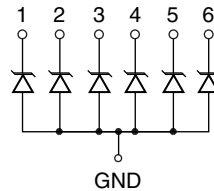

Circuit Diagram

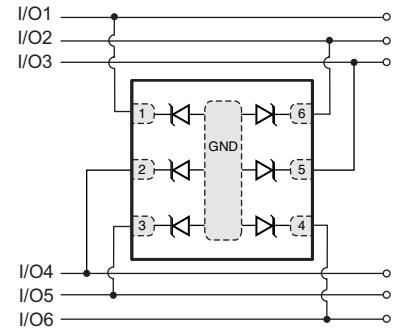

Protection of Six Unidirectional Lines

Circuit Board Layout Recommendations for Suppression of ESD

Good circuit board layout is critical for the suppression of ESD induced transients. The following guidelines are recommended:

- Place the TVS near the input terminals or connectors to restrict transient coupling.
- Minimize the path length between the TVS and the protected line.
- Minimize all conductive loops including power and ground loops.
- The ESD transient return path to ground should be kept as short as possible.
- Never run critical signals near board edges.
- Use ground planes whenever possible.

Package Dimensions, DFN 1.6mm x 1.6mm

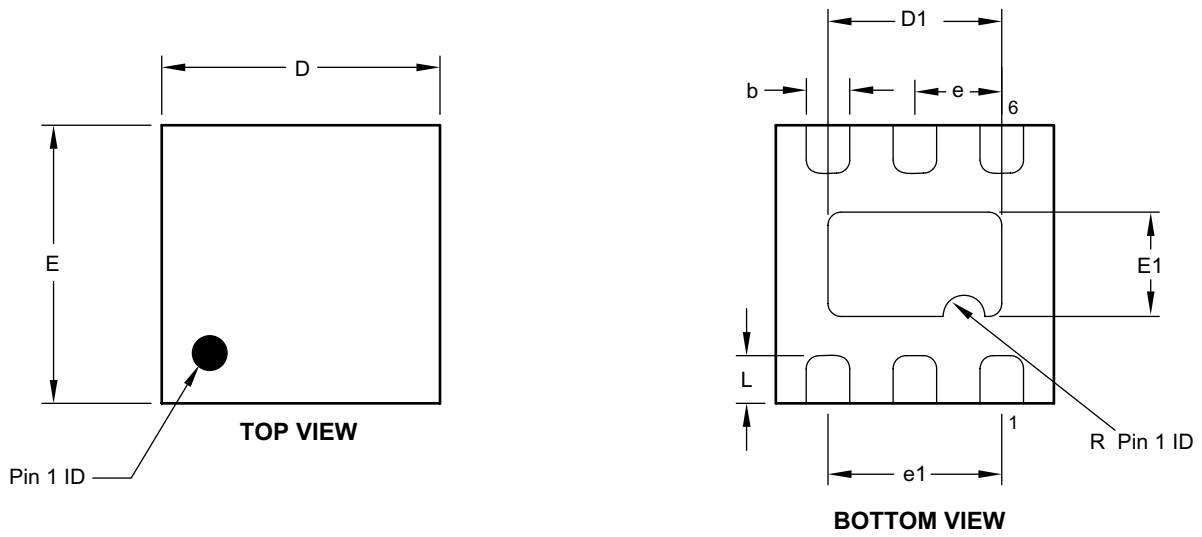

Dimensions in millimeters

Symbols	Min.	Nom.	Max.
A	0.50	0.55	0.60
A1	0.00	0.02	0.05
b	0.22	0.25	0.28
c	1.52 REF.		
D	1.55	1.60	1.65
D1	0.95	1.00	1.05
E	1.55	1.60	1.65
E1	0.55	0.60	0.65
e	0.50 BSC		
e1	1.0 REF		
L	0.225	0.275	0.325
R	0.20		

Notes:

1. Dimensions and tolerancing conform to ASME Y14.5M-1994.
2. All dimensions are in millimeters.

Tape and Reel Dimensions, DFN 1.6mm x 1.6mm

Carrier Tape

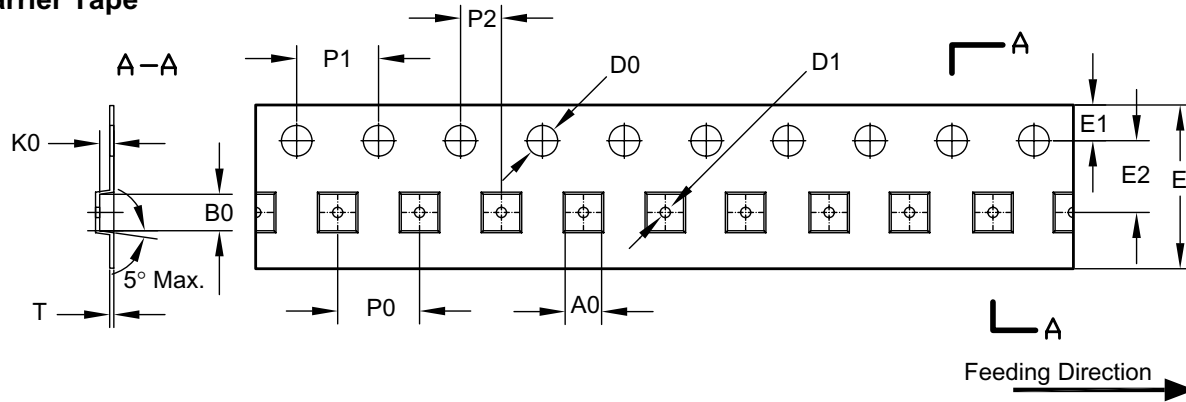

UNIT: mm

Package	A0	B0	K0	D0	D1	E	E1	E2	P0	P1	P2	T
DFN 1.6x1.6	1.78 ±0.05	1.78 ±0.05	0.69 ±0.05	ø1.50 ±0.10	ø0.50 ±0.05	8.00 +0.30 / -0.10	1.75 ±0.10	3.50 ±0.05	4.00 ±0.10	4.00 ±0.10	2.00 ±0.05	0.20 ±0.02

Reel

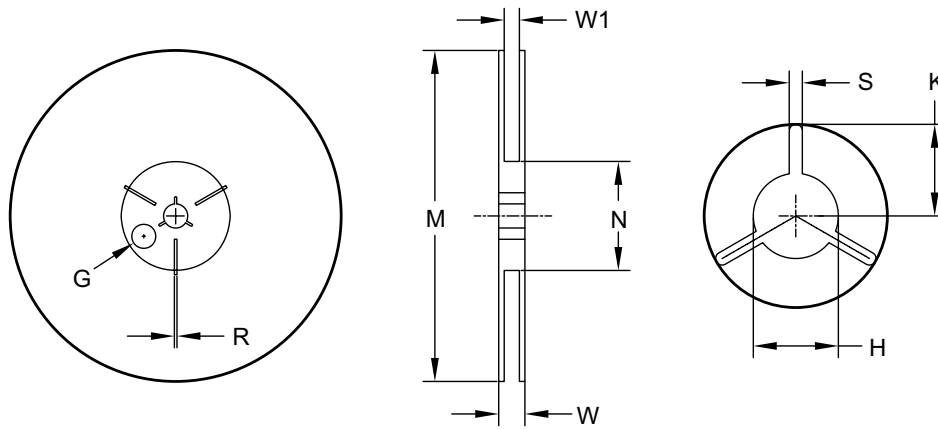

UNIT: mm

Tape Size	Reel Size	M	N	W	W1	H	S	K	E	R
8mm	ø178	ø178.0 ±1.0	ø60.0 ±1.0	11.80 ±0.5	9.0 ±0.5	ø13.0 +0.5 / -0.2	2.40 ±0.10	10.25 ±0.2	ø9.8	—

Leader / Trailer & Orientation

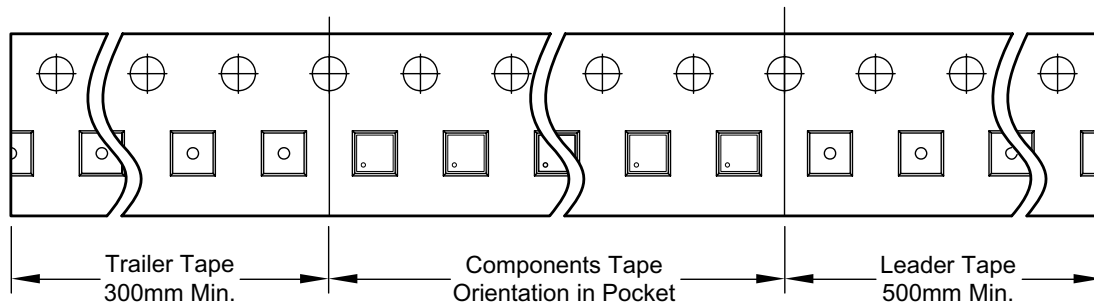

Package Marking

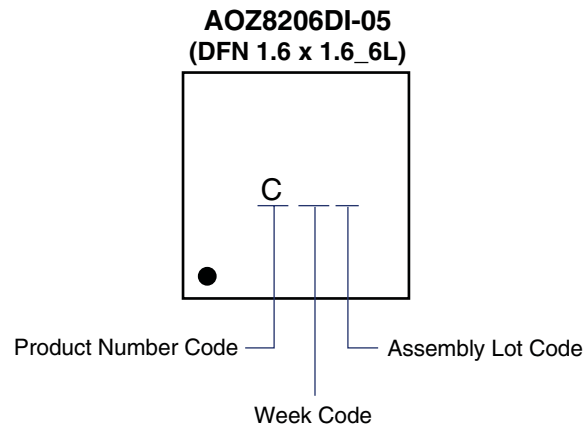

Revision History

Revision	Revised Item
Rev. 1.3	Initial release
Rev. 1.4	Package marking information added

This data sheet contains preliminary data; supplementary data may be published at a later date. Alpha & Omega Semiconductor reserves the right to make changes at any time without notice.

LIFE SUPPORT POLICY

ALPHA & OMEGA SEMICONDUCTOR PRODUCTS ARE NOT AUTHORIZED FOR USE AS CRITICAL COMPONENTS IN LIFE SUPPORT DEVICES OR SYSTEMS.

As used herein:

1. Life support devices or systems are devices or systems which, (a) are intended for surgical implant into the body or (b) support or sustain life, and (c) whose failure to perform when properly used in accordance with instructions for use provided in the labeling, can be reasonably expected to result in a significant injury of the user.
2. A critical component in any component of a life support, device, or system whose failure to perform can be reasonably expected to cause the failure of the life support device or system, or to affect its safety or effectiveness.