

Two axis stepper motor driver expansion board based on the L6470 for STM32 Nucleo

Data brief

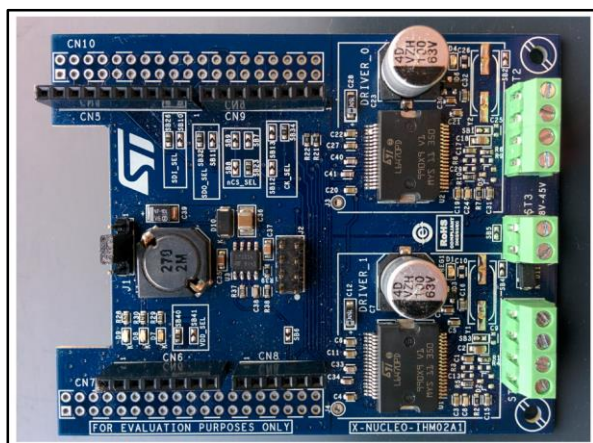

- Five LEDs:
 - 2 green, to indicate that each L6470 is powered
 - 1 orange, to indicate that the digital voltage is on
 - 1 yellow, to indicate when any L6470 is busy
 - 1 red, to indicate when a fault condition occurs (step loss, OCD, thermal pre-warning or shutdown, UVLO, incorrect command, non-performable command) for any L6470
- RoHS compliant

Features

- Operating voltage: 8 V - 45 V DC
- 7 A peak output current (3 A rms) for each motor driver
- Digital voltage supply is selectable (3.3 V or 5.0 V) by a 0 Ω resistor and is provided on main board
- 3.3 V digital voltage supply may be provided by:
 - the STM32 Nucleo board
 - the step-down monolithic power switching regulator soldered on the expansion board (through jumper selection, it can also be used to supply the STM32 Nucleo board)
- USART communication
 - enables receiving of commands from a PC
 - enables sending information to a PC
 - Requires no dedicated cable; uses the Type A to Type Mini-B USB cable already used to supply the STM32 Nucleo board
- SPI interface (may be connected in a daisy chain configuration)
- Equipped with Arduino UNO R3 connectors
- Layout compatible with ST morpho connectors

Description

The X-NUCLEO-IHM02A1 is a two axis stepper motor driver expansion board based on the L6470. It provides an affordable and easy-to-use solution for low voltage motor control driving for stepper motors in your STM32 Nucleo project.

The expansion board includes two L6470s, a fully-integrated micro stepping motor driver used to control stepper motors by means of high-end motion control commands received through SPI. It is capable of driving one or two stepper motors when plugged into an STM32 Nucleo board.

This board is equipped with Arduino UNO R3 connectors and the layout is also compatible with ST morpho connectors. One or more of these expansion boards can be plugged into an STM32 Nucleo board to control one or more stepper motors.

Each SPI peripheral of each L6470 is connected in a daisy chain configuration.



Schematic diagram

Figure 1: X-NUCLEO-IHM02A1 circuit schematic (1 of 4)

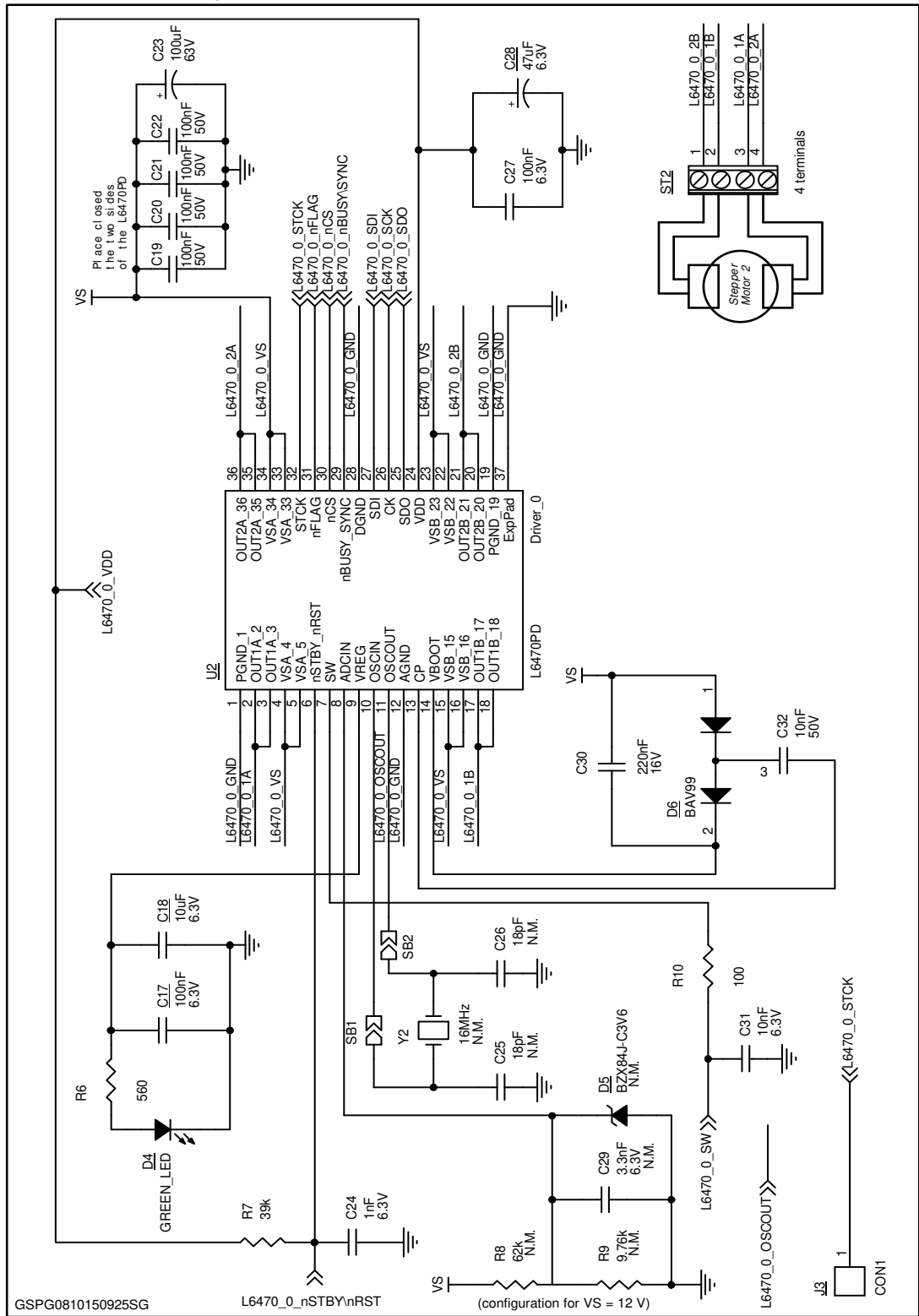

Figure 2: X-NUCLEO-IHM02A1 circuit schematic (2 of 4)

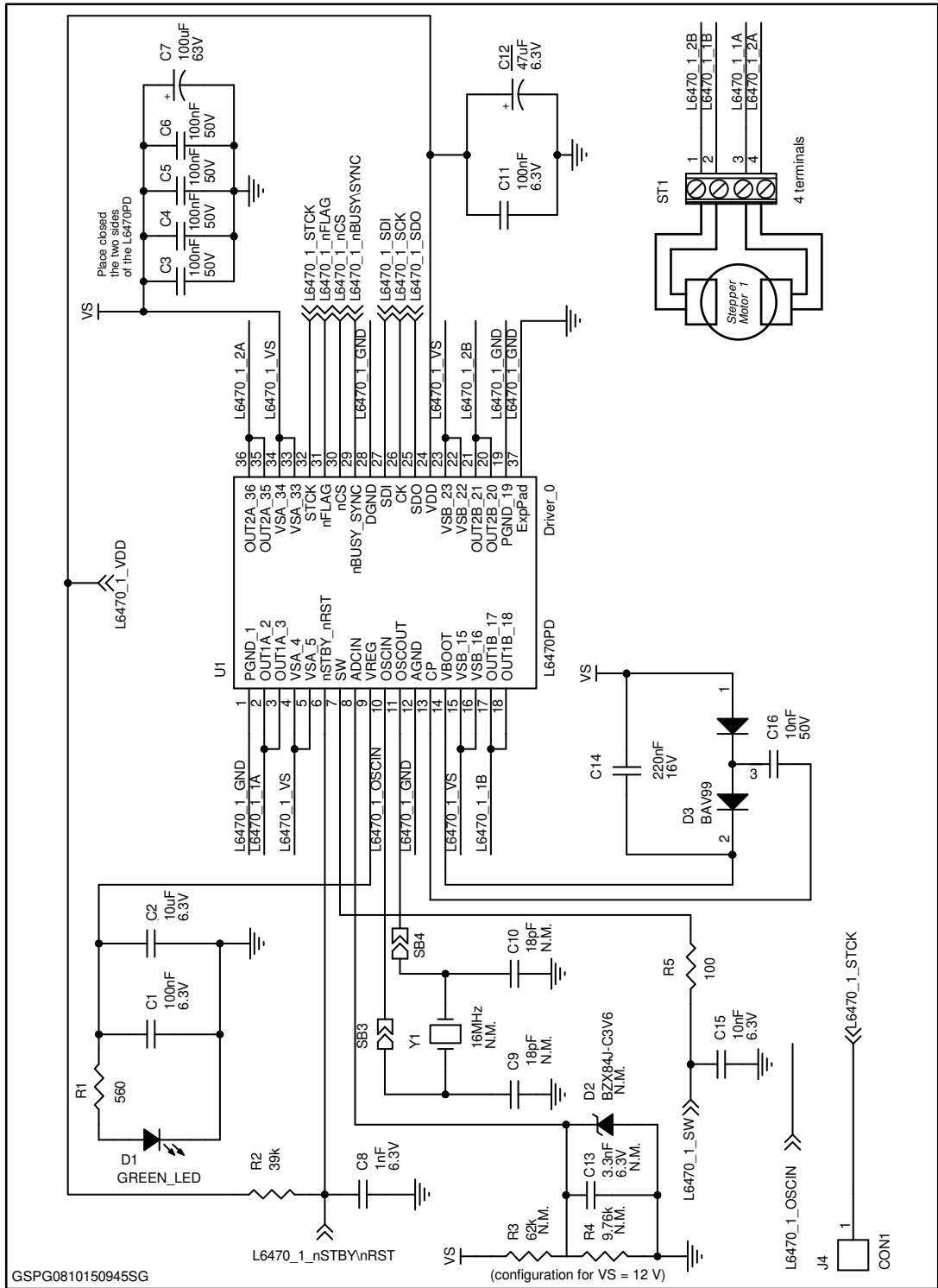
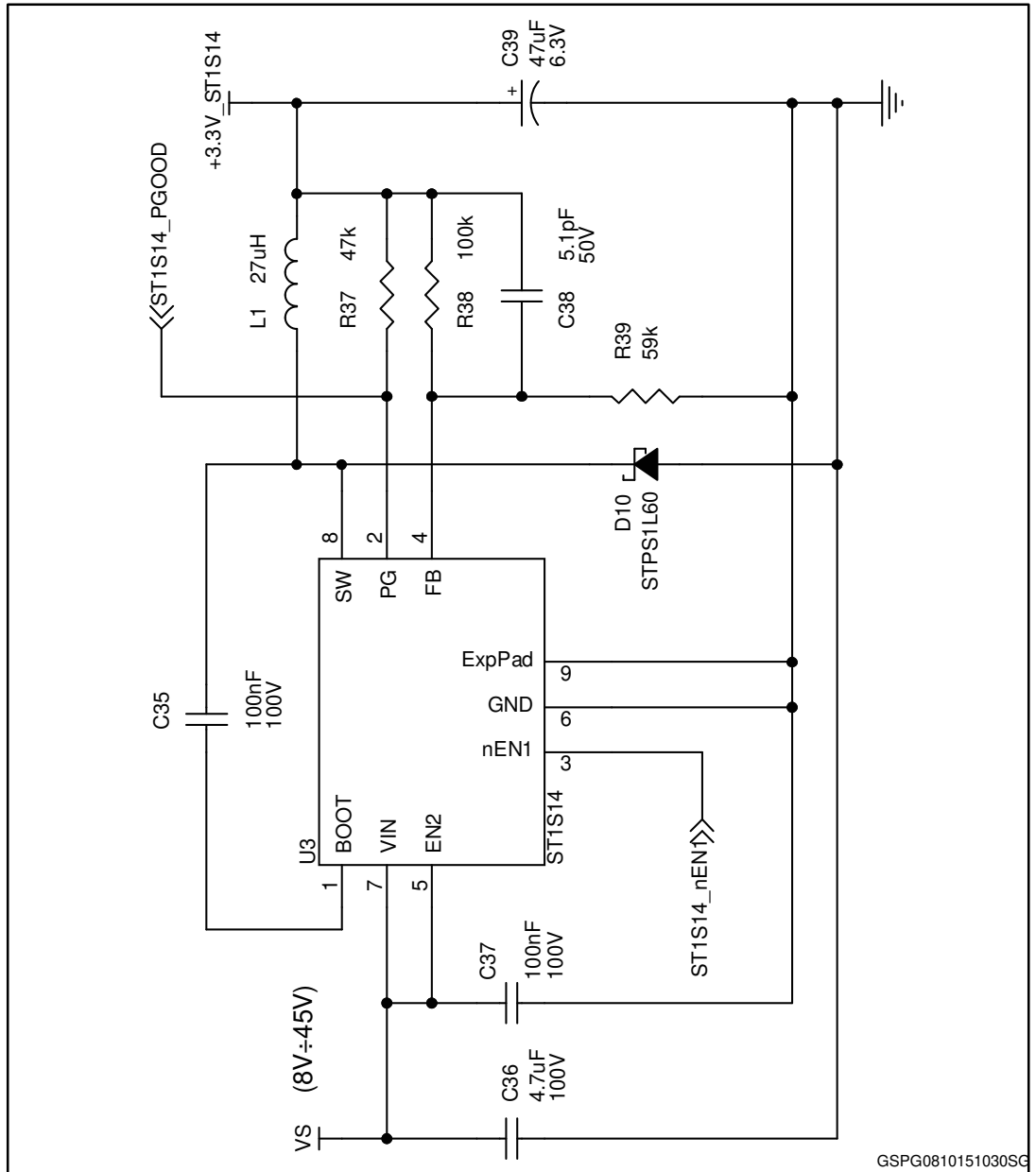

Figure 3: X-NUCLEO-IHM02A1 circuit schematic (3 of 4)



Revision history

Table 1: Document revision history

Date	Version	Changes
19-Oct-2015	1	Initial release.
16-Dec-2015	2	Changed title description on cover page.

IMPORTANT NOTICE – PLEASE READ CAREFULLY

STMicroelectronics NV and its subsidiaries ("ST") reserve the right to make changes, corrections, enhancements, modifications, and improvements to ST products and/or to this document at any time without notice. Purchasers should obtain the latest relevant information on ST products before placing orders. ST products are sold pursuant to ST's terms and conditions of sale in place at the time of order acknowledgement.

Purchasers are solely responsible for the choice, selection, and use of ST products and ST assumes no liability for application assistance or the design of Purchasers' products.

No license, express or implied, to any intellectual property right is granted by ST herein.

Resale of ST products with provisions different from the information set forth herein shall void any warranty granted by ST for such product.

ST and the ST logo are trademarks of ST. All other product or service names are the property of their respective owners.

Information in this document supersedes and replaces information previously supplied in any prior versions of this document.

© 2015 STMicroelectronics – All rights reserved