

Outline Drawing and Circuit Diagram

Dimension	Inches	Millimeters
A	0.55 Min.	14.0 Min.
B	0.12 Max.	3.0 Max.
C	0.16	4.0
D	0.39	1.0
E	0.098 Max.	2.5 Max.

Dimension	Inches	Millimeters
F	0.016	0.4
G	0.10	2.5
H	0.018	0.45
J	0.004	0.1
K	0.29 Max.	7.5 Max.



Description:

The BS08D-T112 bilateral switch is a silicon planar monolithic integrated circuit with the electrical characteristics of a bilateral thyristor. The device is designed to switch at 7 to 9 volts with a 0.01%/°C temperature coefficient and have excellently matched characteristics in both directions.

Features:

- Low Switching Voltage of 7 to 9 Volts
- Excellent Switching Voltage Temperature Characteristics (0.01%/°C)
- High Reliability Devices
- Gate Electrode Facilitating Switching Operation Control and Synchronization

Applications:

- Trigger Circuits for Thyristor or Triac, Oscillators, Timers

Ordering Information:

BS08D-T112 is tape and fencil packaged (2500/box).

BS08D-T112
Silicon Bilateral Switch

Absolute Maximum Ratings, $T_j = 25^\circ\text{C}$ unless otherwise specified

Characteristics	Symbol	BS08D-T112	Units
DC Forward Anode Current	I_T	175	mA
Repetitive Peak Forward Current (1% Duty Cycle, 10 μs Pulsewidth), $T_a = 100^\circ\text{C}$	—	1.0	Amperes
Non-repetitive Peak Forward Current (10 μs Pulsewidth)	—	2.0	Amperes
Power Dissipation	P_T	450	mW
DC Gate Current	I_G	5	mA
Storage Temperature	T_{stg}	-55 to 125	$^\circ\text{C}$
Operating Temperature	T_j	-55 to 125	$^\circ\text{C}$

Electrical and Mechanical Characteristics, $T_j = 25^\circ\text{C}$ unless otherwise specified

Characteristics	Symbol	Test Conditions	Min.	Typ.	Max.	Units
Switching Voltage	V_S	$T_a = 25^\circ\text{C}$	7	8	9	Volts
Switching Current	I_S	$T_a = 25^\circ\text{C}$	—	—	200	μA
Absolute Switching Voltage Difference	$ V_{S1} - V_{S2} $	$T_a = 25^\circ\text{C}$	—	—	0.5	Volts
Absolute Switching Current Difference	$ I_{S1} - I_{S2} $	$T_a = 25^\circ\text{C}$	—	—	100	μA
Holding Current	I_H	$T_a = 25^\circ\text{C}$	—	—	1.5	mA
Off-state Current	I_D	$V_D = 5\text{V}, T_a = 25^\circ\text{C}$	—	—	1.0	μA
		$V_D = 5\text{V}, T_a = 85^\circ\text{C}$	—	—	10	μA
Temperature Coefficient of Switching Voltage	—	$T_a = -55$ to 85°C	—	± 0.01	—	$\%/^\circ\text{C}$
Peak On-state Voltage	V_T	$I_T = 175\text{mA}, T_a = 25^\circ\text{C}$	—	—	1.4	Volts
Gate Trigger Current	I_{GT}	$V_D = 5\text{V}, T_a = 25^\circ\text{C}$	10	—	200	μA
Gate Non-trigger Voltage	V_{GD}	$V_D = 5\text{V}, T_a = 85^\circ\text{C}$	0.2	—	—	Volts

BS08D-T112
Silicon Bilateral Switch

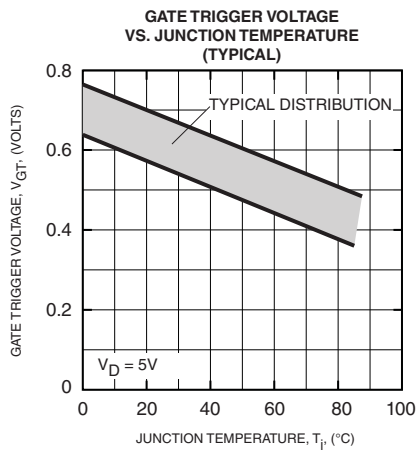
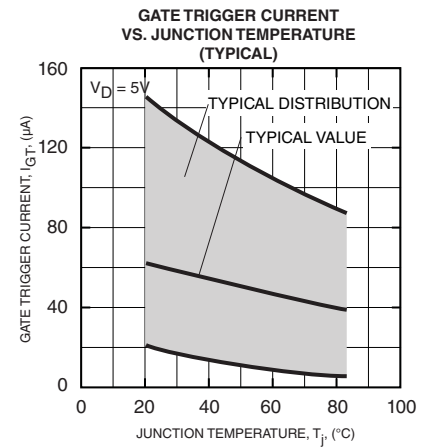
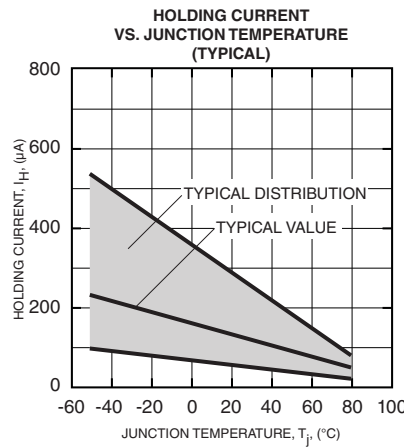
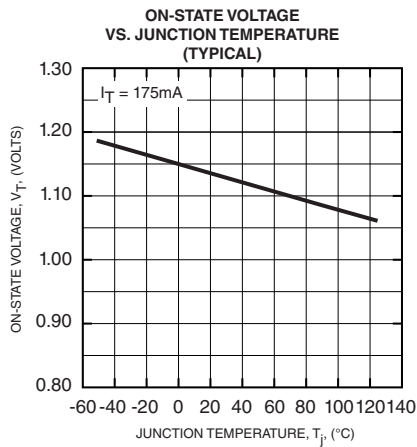
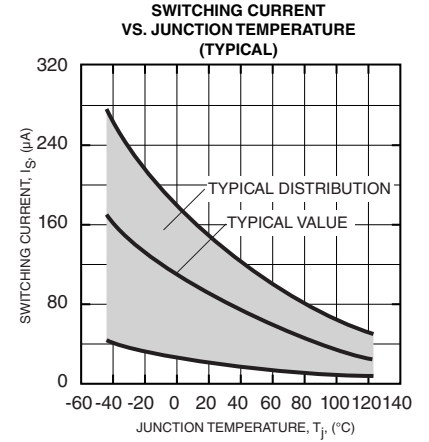
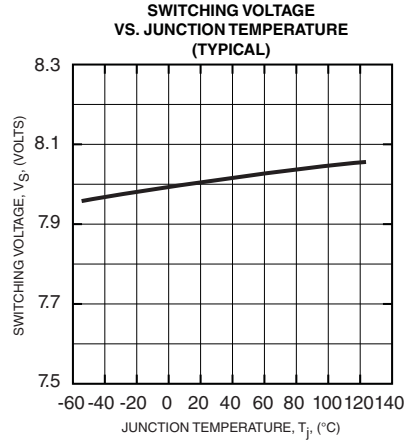
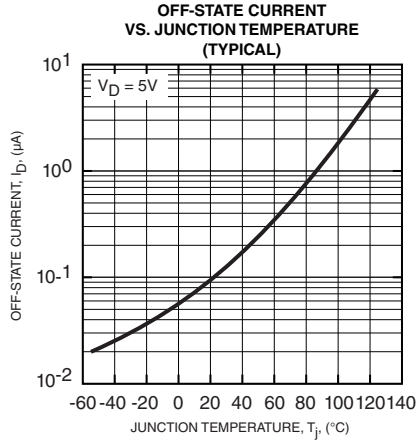

BS08D-T112
Silicon Bilateral Switch

APPLICATION EXAMPLES

THYRISTOR TRIGGER CIRCUIT

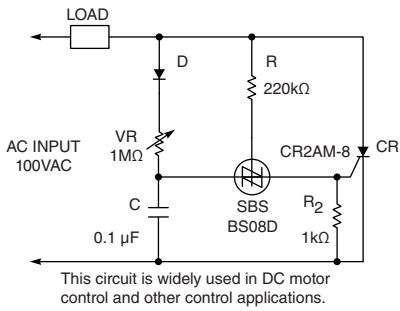

EQUIVALENT CIRCUIT

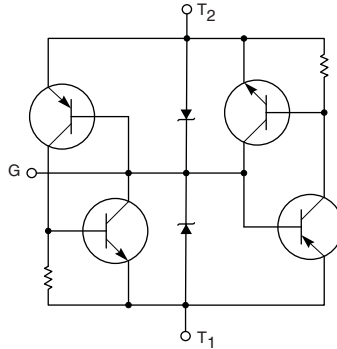

STATIC CHARACTERISTICS

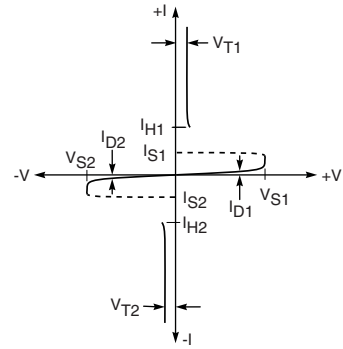

TRIAC TRIGGER CIRCUIT

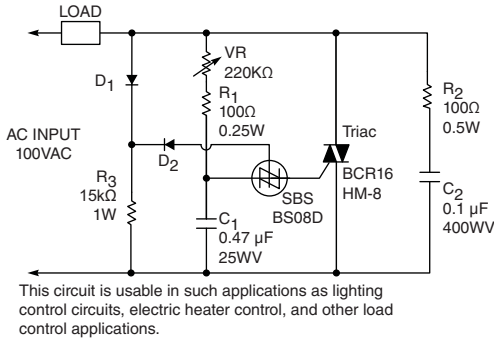

CIRCUIT SYMBOL

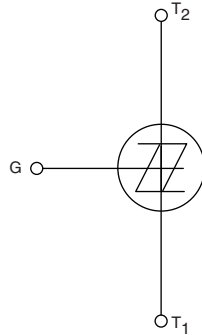

GATE CHARACTERISTICS MEASUREMENT CIRCUIT

