

## TCFS-\*\*-\*\*\*-2\*\*-25CH

See over for Part Numbering System

CONDUCTIVE HOT-MELT ADHESIVE

a) Part as supplied.

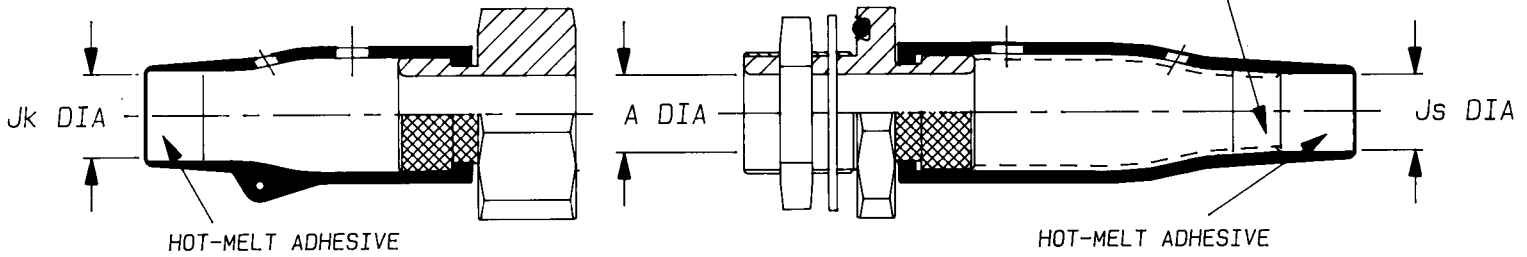

b) Part after unrestricted recovery.

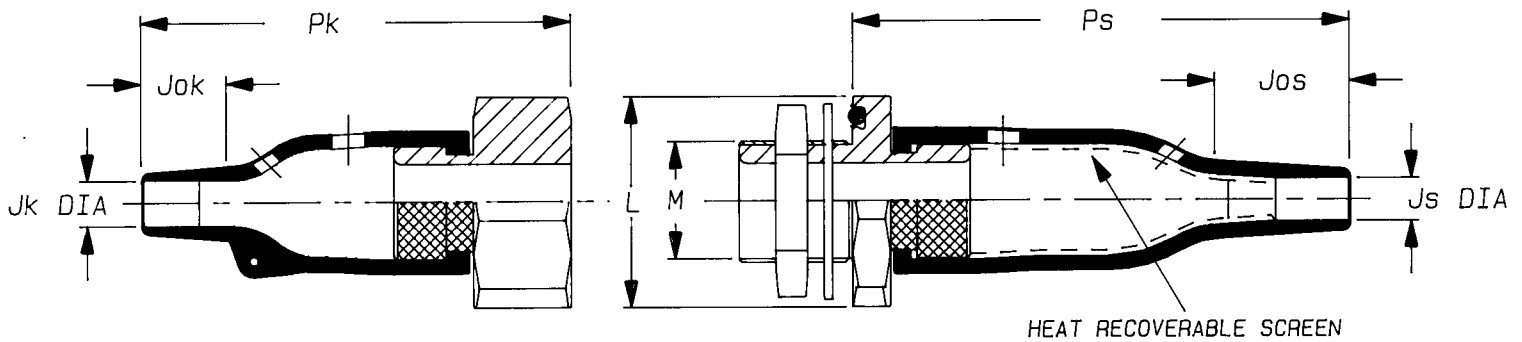

KITS TO INCLUDE CLEANING TISSUE, 1 PIECE 100 GRIT EMERY CLOTH & 1 PIECE OF ATUM.  
KIT TO BE USED IN CONJUNCTION WITH TCFS INSTALLATION PROCEDURE.

Dimensions (in millimetres)

PART No.	A		Jk		Js		M THREAD	A/F Nut	L NOM	Pk		Ps		Jok	Jos
	min	max	min	max	min	max				±10%	±10%	Ref	Ref		
	a	b	a	b	a	b				b	b	b	b		
TCFS-12	7.4	5.7	11	5.7	9	5.0	M12 x 1.5	17	24	±10%	±10%	9	15		
TCFS-16	10.1	6.0	15	6.0	13	6.0	M16 x 1.5	22	29	±10%	±10%	12	17		
TCFS-20	14.1	7.2	19	7.2	15	7.2	M20 x 1.5	27	34	±10%	±10%	17	20		
TCFS-24	19.1	8.5	23	8.5	19	8.5	M24 x 1.5	30	38	±10%	±10%	20	25		
TCFS-30	24.1	10.0	29	10.0	24	10.0	M30 x 1.5	36	47	±10%	±10%	21	30		
TCFS-36	30.1	15.8	35	15.8	33	15.8	M36 x 1.5	41	52	±10%	±10%	39	30		

Copyright (!)  
Urheberrechte

The copyright in this drawing is the property of Raychem Ltd. The drawing is issued on condition that it is not copied, reproduced or disclosed to a third party, either in whole or in part without the prior written consent of Raychem Ltd.

Drawn D.MURRAY Checked *JK* Issue 5 Date May 1996

Conforms to ISO Recommendations  
3rd Angle Projection  
Not to Scale

Approval  
Design

*A.A.S.*

MKTG.

*JK*

Q.A.

*JK*

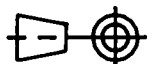

Iss.	Date	E.C.R. No.	Details of Change
2	November 1991	H0044	Ja CHANGED
3	January 1992	H0125	L was %
4	November 1992	H0125	S/S 30 L WAS 48
5	May 1996	H0295	S/S 12 Pk WAS 37

Material

(-25) DIESEL RESISTANT ELASTOMER

Part Numbering System.

TCFS-\*\*-\*\*\*-2\*\*-25CH

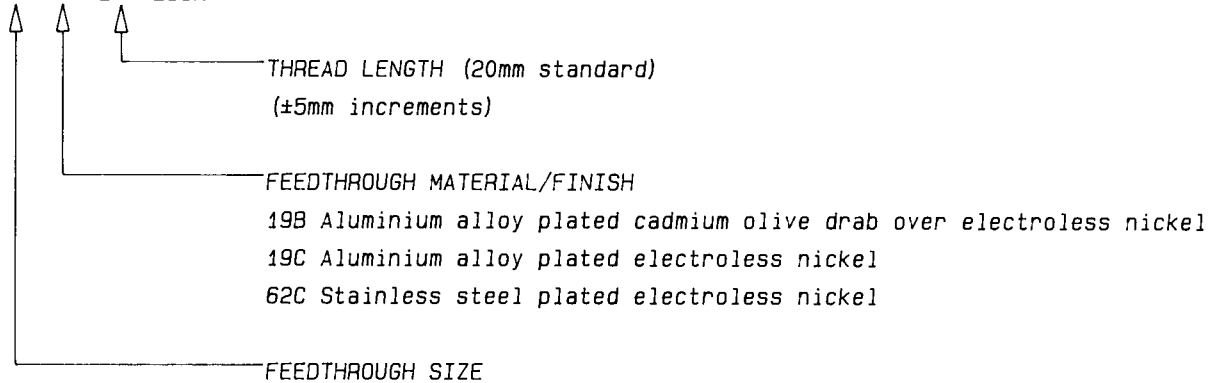

Raychem  
Thermofit Division, Europe,  
Swindon, Wiltshire, England.  
Telephone: (0793) 528171 Fax: 573923