

2xØ3.10±0.12x11.18 DP
 RECOMMENDED SCREW: 6-19 [M3.63 x 1.34]
 THREAD-FORMING SCREW,
 TORQUE: 11-15 IN-LB [1.24-1.70 NM]

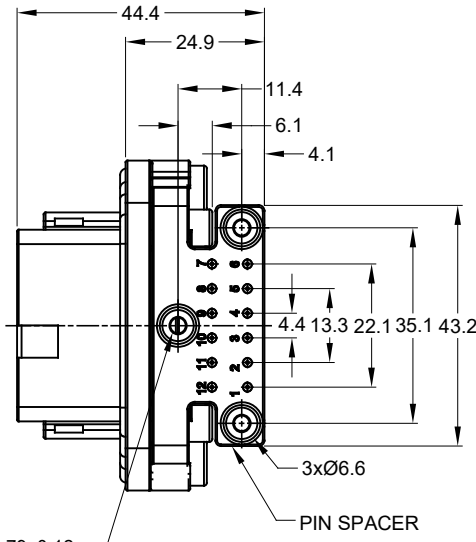

REVISIONS					
REV	ECO	DESCRIPTION	DATE	BY	APPR
A1	--	RELEASE NEW DRAWING	14/DEC/18	BROOK	TOMMY
A2	--	REVISED DRAWING	10JUL20	JHEAD	DH

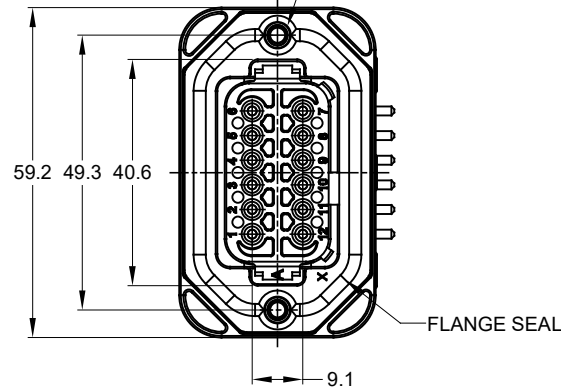
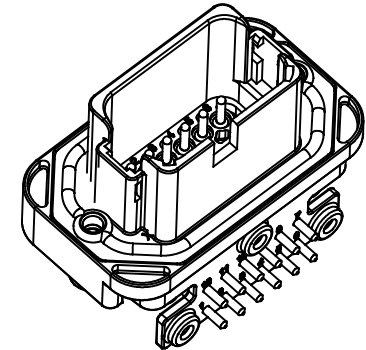
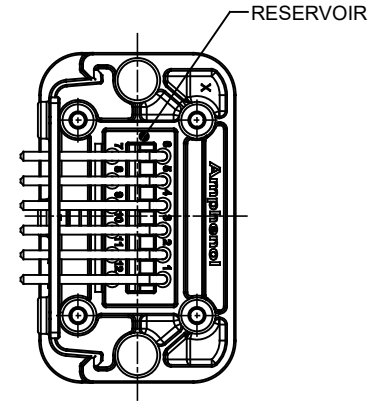

NOTES: UNLESS OTHERWISE SPECIFIED

- MATERIAL:
 HOUSING: THERMOPLASTIC
 SEAL: SILICONE RUBBER
 CONTACT: COPPER ALLOY
- MODIFICATIONS: FLANGE, PCB MOUNT, RIGHT ANGLE, EXTENDED LENGTH SHROUD
- SPECIFICATIONS:
 3.1 CURRENT RATING: 13 AMPS
 3.2 OPERATING TEMPERATURE: -55°C TO +125°C
 3.3 DIELECTRIC WITHSTANDING VOLTAGE: LESS THAN 2 MILLIAMPS CURRENT LEAKAGE @ 1500 VOLTS AC.
 3.4 INSULATION RESISTANCE: 1000 MEGOHMS MIN @ 25°C.
 3.5 MOISTURE RESISTANCE: IP67 (MATED CONDITION)
 3.6 MATING CYCLE DURABILITY: 100 CYCLES
 3.7 RoHS COMPLIANT
- MATING PART: AT06-12S* PLUG (* = MODIFICATIONS)
- ALL DIMENSIONS ARE FOR REFERENCE USE ONLY.
- POTTED CONNECTORS SPECIFIED FOR UP TO 5 P.S.I. APPLICATIONS.

RECOMMENDED SCREW: 4-20 [M3.12 x 1.27]
 THREAD-FORMING SCREW,
 TORQUE: 6-10 IN-LB [0.68-1.13 NM]

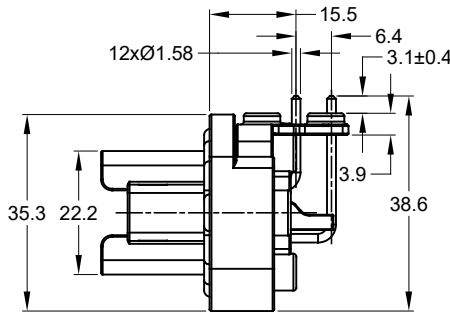

AT13-12PX-BM1X		REF: DT13-12PA-B016, DT13-12PB-B016, DT13-12PC-B016, DT13-12PD-B016			
PART NUMBER		DESCRIPTION			
QUANTITY	MATERIALS LIST				
UNLESS OTHERWISE SPECIFIED		SIGNATURES	DATE	 Sine Systems - www.amphenol-sine.com 44724 Morley Drive Clinton Township, MI 48036 BOARDLOCK PCB MOUNT RECEPTACLE, 12 PIN, RA FLANGE, EXT. LGTH, AT SERIES	
1) All dimensions are in metric (mm).		DRAWN: BROOKING	14/DEC/18		
2) Tolerances are as follows:		CHECKED: ORIONLI	14/DEC/18		
1 PL DEC ±0.30 2 PL DEC ±0.15 3 PL DEC ±0.08 Fractions ±1/64 Angles ±1°		ENGINEER:			
3) Note reference =		APPROVAL: TOMMYXIE	14/DEC/18	CUSTOMER:	
MATERIAL SPECIFICATIONS:		THIS DRAWING IS SUPPLIED FOR INFORMATION ONLY. DESIGN FEATURES, SPECIFICATIONS AND PERFORMANCE DATA SHOWN HEREON ARE THE PROPERTY OF THE AMPHENOL CORPORATION. NO RIGHTS OF REPRODUCTION ARE IMPLIED. ALL DIMENSIONS ARE SUBJECT TO NORMAL MANUFACTURING VARIATIONS.			
PROCESS SPECIFICATIONS:		SIZE: B	TYPE: C-	DWG NO: AT13-12PX-BM1X	REVISION: A2
NEXT ASSY:		SCALE: NONE	SHEET 1 OF 3		

TITLE: PCB MNT RECEPT 12PIN, RA FLANGE, EXT LGTH, AT SERIES
 DWG NO: AT13-12PX-BM1X
 REV: A2
 SH: 1
 OF: 3

P/N AT13-12PA-BM1X
KEY-A CONFIGURATION
STANDARD COLOR: GREY

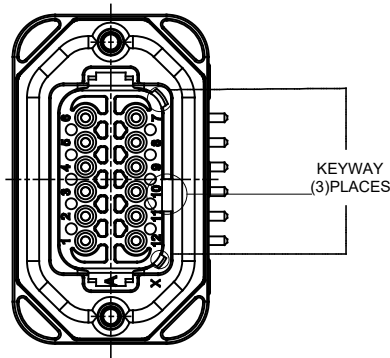

AT13-12PA-BMXX VARIANTS		
CONTACT PLATING	POTTING OR NOT IN RESERVOIR	PART NUMBER
TIN	NO POTTING	AT13-12PA-BM16
TIN	POTTING	AT13-12PA-BM17
GOLD	NO POTTING	AT13-12PA-BM18
GOLD	POTTING	AT13-12PA-BM19

REVISIONS					
REV	ECO	DESCRIPTION	DATE	BY	APPR
A1	--	RELEASE NEW DRAWING	14/DEC/18	BROOK	TOMMY
A2	--	REVISED DRAWING	10JUL20	JHEAD	DH

P/N AT13-12PB-BM1X
KEY-B CONFIGURATION
STANDARD COLOR: BLACK

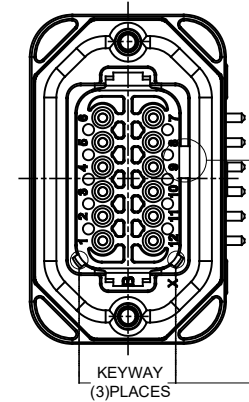

AT13-12PB-BMXX VARIANTS		
CONTACT PLATING	POTTING OR NOT IN RESERVOIR	PART NUMBER
TIN	NO POTTING	AT13-12PB-BM16
TIN	POTTING	AT13-12PB-BM17
GOLD	NO POTTING	AT13-12PB-BM18
GOLD	POTTING	AT13-12PB-BM19

AT13-12PX-BM1X		DESCRIPTION		ITEM
QUANTITY	PART NUMBER			
MATERIALS LIST				
<small>UNLESS OTHERWISE SPECIFIED</small> 1) All dimensions are in metric (mm). 2) Tolerances are as follows: 1 PL DEC ±0.30 2 PL DEC ±0.15 3 PL DEC ±0.08 Fractions ±1/64 Angles ±1° 3) Note reference =		<small>SIGNATURES</small> DRAWN: BROOK DING 14/DEC/18 CHECKED: ORION LI 14/DEC/18 APPROVAL: TOMMY XIE 14/DEC/18		 Sine Systems - www.amphenol-sine.com 44724 Morley Drive Clinton Township, MI 48036
<small>MATERIAL SPECIFICATIONS:</small> THIS DRAWING IS SUPPLIED FOR INFORMATION ONLY. DESIGN FEATURES, SPECIFICATIONS AND PERFORMANCE DATA SHOWN HEREON ARE THE PROPERTY OF THE AMPHENOL CORPORATION. NO RIGHTS OF REPRODUCTION ARE IMPLIED. ALL DIMENSIONS ARE SUBJECT TO NORMAL MANUFACTURING VARIATIONS.		<small>CUSTOMER:</small> BOARDLOCK PCB MOUNT RECEPTACLE, 12 PIN, RA FLANGE, EXT. LGTH, AT SERIES		
<small>PROCESS SPECIFICATIONS:</small> NEXT ASSY:		<small>SIZE</small> B C-	<small>TYPE</small> AT13-12PX-BM1X	<small>DWG NO.</small> AT13-12PX-BM1X
<small>SCALE</small> NONE		<small>REVISION</small> A2		<small>SHEET</small> 2 <small>OF</small> 3

TITLE: PCB MNT RECEPT 12PIN RA FLANGE EXT LGTH AT SERIES DWG NO: AT-3-12PX-BM1X REV: A2 SH: 2 OF: 3

REVISIONS					
REV	ECO	DESCRIPTION	DATE	BY	APPR
A1	--	RELEASE NEW DRAWING	14/DEC/18	BROOK	TOMMY
A2	--	REVISED DRAWING	10JUL20	JHEAD	DH

P/N AT13-12PC-BM1X
KEY-C CONFIGURATION
STANDARD COLOR: GREEN

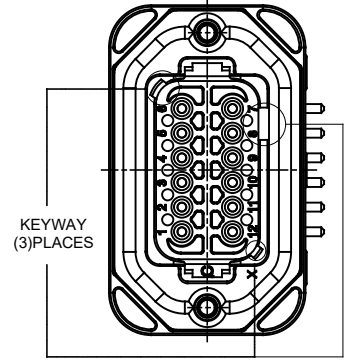

KEYWAY
(3)PLACES

P/N AT13-12PD-BM1X
KEY-D CONFIGURATION
STANDARD COLOR: BROWN

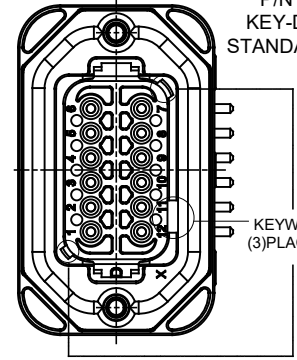

KEYWAY
(3)PLACES

AT13-12PC-BMXX VARIANTS		
CONTACT PLATING	POTTING OR NOT IN RESERVOIR	PART NUMBER
TIN	NO POTTING	AT13-12PC-BM16
TIN	POTTING	AT13-12PC-BM17
GOLD	NO POTTING	AT13-12PC-BM18
GOLD	POTTING	AT13-12PC-BM19

AT13-12PD-BMXX VARIANTS		
CONTACT PLATING	POTTING OR NOT IN RESERVOIR	PART NUMBER
TIN	NO POTTING	AT13-12PD-BM16
TIN	POTTING	AT13-12PD-BM17
GOLD	NO POTTING	AT13-12PD-BM18
GOLD	POTTING	AT13-12PD-BM19

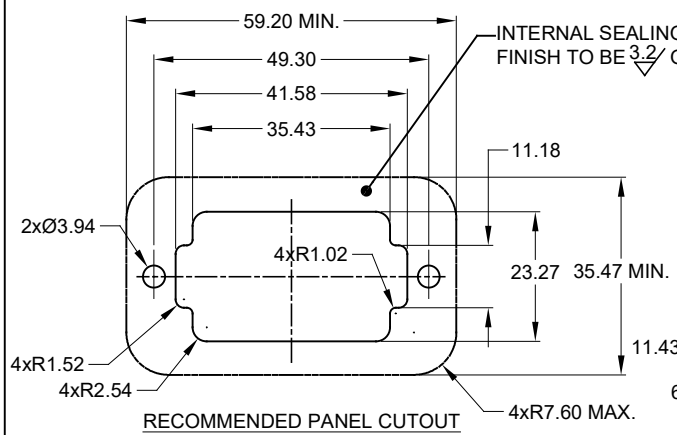

INTERNAL SEALING SURFACE
FINISH TO BE 3.2 OR BETTER $\sqrt{0.13}$

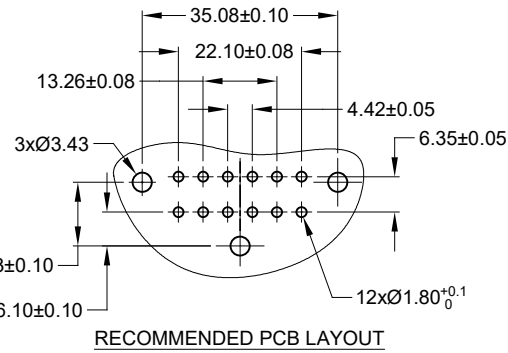

AT13-12PX-BM1X		PART NUMBER		DESCRIPTION		ITEM
QUANTITY		MATERIALS LIST				
UNLESS OTHERWISE SPECIFIED: 1) All dimensions are in metric (mm). 2) Tolerances are as follows: 1 PL DEC ±0.30 2 PL DEC ±0.15 3 PL DEC ±0.08 3) Note reference = Δ		SIGNATURES		DATE		<p>Sine Systems - www.amphenol-sine.com 44724 Morley Drive Clinton Township, MI 48036</p>
MATERIAL SPECIFICATIONS:		DRAWN: BROOK DING		14/DEC/18		
PROCESS SPECIFICATIONS:		CHECKED: ORION LI		14/DEC/18		
NEXT ASSY:		ENGINEER: TOMMY XIE		14/DEC/18		
APPROVAL:		CUSTOMER:		THIS DRAWING IS SUPPLIED FOR INFORMATION ONLY. DESIGN FEATURES, SPECIFICATIONS AND PERFORMANCE DATA SHOWN HEREON ARE THE PROPERTY OF THE AMPHENOL CORPORATION. NO RIGHTS OF REPRODUCTION ARE IMPLIED. ALL DIMENSIONS ARE SUBJECT TO NORMAL MANUFACTURING VARIATIONS.		BOARDLOCK PCB MOUNT RECEPTACLE, 12 PIN, RA FLANGE, EXT. LGTH. AT SERIES
SIZE: B	TYPE: C-	DWG NO: AT13-12PX-BM1X		REVISION: A2		SCALE: NONE
SHEET 3 OF 3						

TITLE PCB MNT RECEPT 12PIN RA FLANGE EXT LGTH AT SERIES
DWG NO: AT13-12PX-BM1X
REV: A2
SH: 3
OF: 3