

# 750 Series Mechanical Timer Switches

---

Highpower miniature mechanical timer switches are momentary switches that provide a time delay after release. Pressing on the actuator instantly changes the state of an internal snap action switch. Once released, the actuator slowly returns to the rest position, creating a time delay. This delay is controlled by adjusting the position of a brass adjustment screw. All adjustment screws have a dot position indicator machined into the head and use a spring under the head to maintain the set position. The delay interval is controlled by the internal flow of air into an integrated air diaphragm. The internal air control assembly is made to exacting tolerances through precision machining.

The internal micro switch is Form Z, which allows one pole to control a load and a second pole for switch position monitoring applications. Made in USA with RoHS compliant materials.

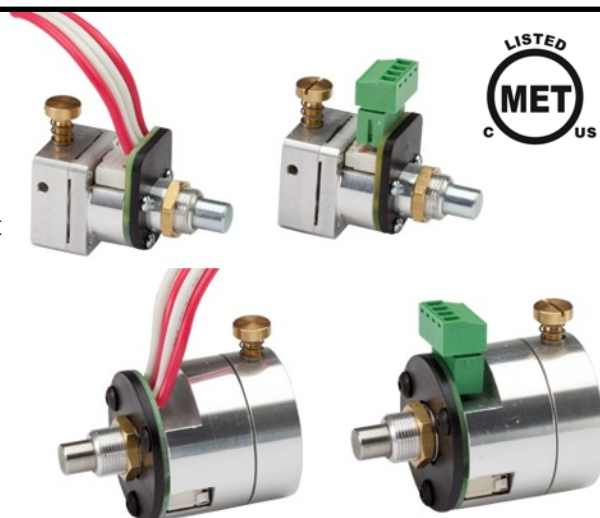

---

## Applications

Highpower timers run without external supply power and can provide timing cycles for use with general control applications. They are often used in the security industry in door control applications. The release of electromagnetic door locks for timing cycles over 15 or 30 seconds are the typical application, but many more potential general control applications can be realized. Working range of the time delay can be up to 60 seconds. Because atmospheric air is used to regulate the device, changes in temperature, pressure and air density can affect the timing cycle delay.

---

## Specifications

**CONTACT RATING:** MAX 5 Amps @ 125 VAC Silver contacts. Change Over NO, NC.

UL1054/CSA22.2 No. 55 - 6000 operations. 0-15 VDC 5 A, general rating 50,000 operations.

15-30 VDC 3A, general rating 50,000 operations.

**CYCLE LIFE:** Microswitch tested to over 50,000 cycles of operation. Mechanical components tested to 1 million cycles of operation.

**HOUSING MATERIAL:** 6026 Aluminum

**PLUNGER MATERIAL:** 303 Stainless Steel

**INSULATING MATERIAL:** SE100 Resin. Termination is 18 AWG listed wire or 3.81mm removable terminal block.

**MOUNTING THREAD:** 15/32"-32 Thread with included brass mounting nut.

**CUSTOMIZATION:** Unique mounting configurations available including stop length and thread size.

Metric mounting threads available. Custom plunger lengths available. Consult the factory.

**DELAY REPEATABILITY:** (+/-) 1.5 seconds at room temperature under constant atmospheric conditions.

**LISTING:** Listed to UL508 and CSA C22.2 No. 14-M05 with MET Labs File# E113051. Internal use only.

---

## Part Numbers

750-1000 - 1.5" dia. mechanical timer with wire leads, designed for 1-60 second operation.

750-2000 - 1.5" dia. mechanical timer with terminal block, design for 1-60 second operation.

750-4000 - 1" square miniature mechanical timer with wire leads, designed for 1-45 second operation.

750-4100 - 1" square miniature mechanical timer with terminal block, designed for 1-45 second operation.

DATE	SYM	REVISION RECORD	AUTH.	DR.	CK.
11/09	-	INITIAL RELEASE	.	WJR	

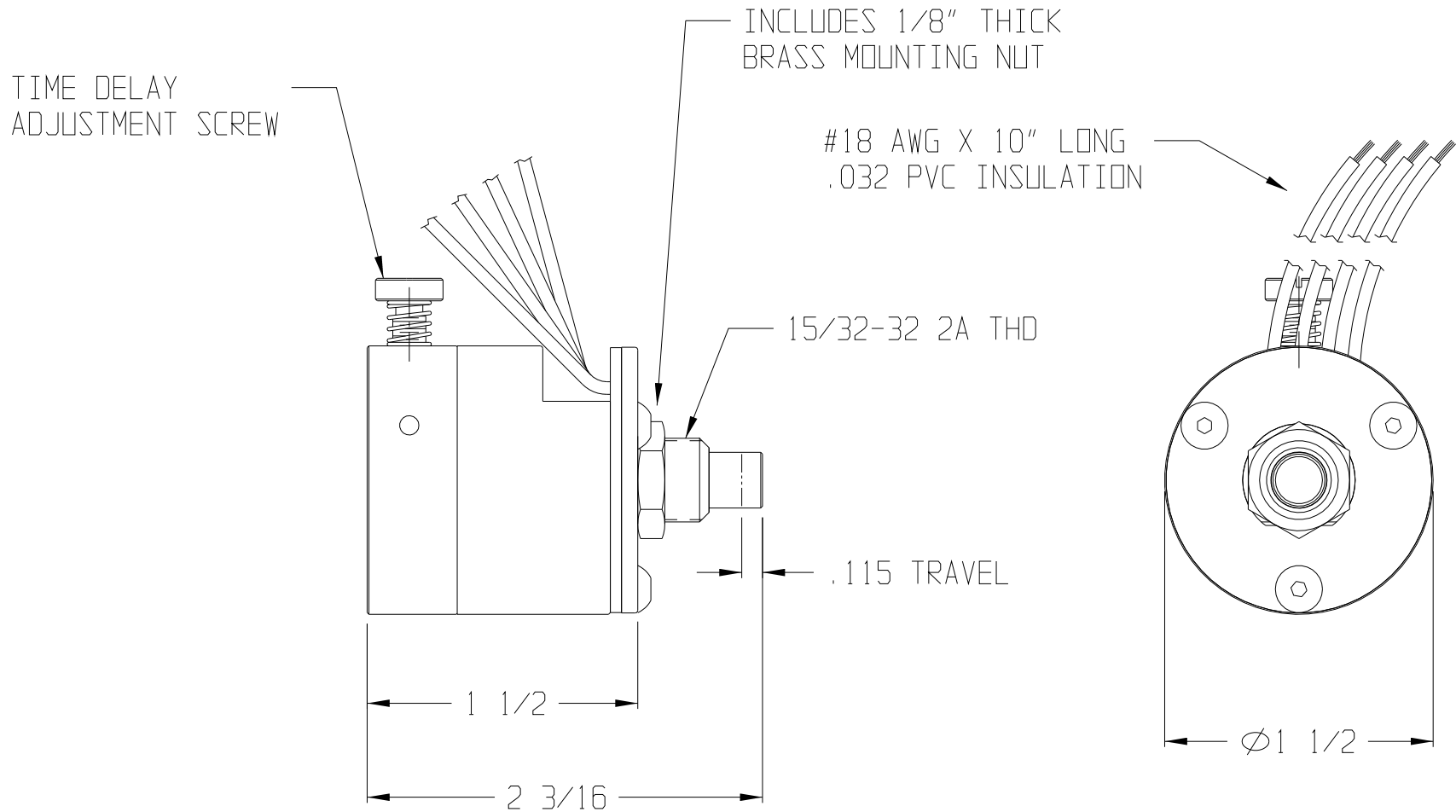

- 4. CONSTRUCTION: 6026 ALUMINUM HOUSING; STAINLESS STEEL PLUNGER.
- 3. FORM Z CONTACT CONFIGURATION
- 2. SWITCH: 5 AMP 125 VAC

NOTES: 1. WIRES: #18 AWG X 10" LG, 2 WHITE (N.O.) 2 RED (N.C.).

TOLERANCES (EXCEPT AS NOTED)		<div style="text-align: center;">  <p><b>SECURITY PRODUCTS, LLC</b></p> <p>290 PRATT STREET, 4TH FLOOR, MERIDEN, CT 06450</p> </div>			
DECIMAL	± -				
FRACTIONAL	± -	DATA SHEET - PNEUMATIC TIMER, FORM Z			
ANGULAR	± -	DATE 11/19/09	DRAWING NUMBER 750-1000		REV. -

DATE	SYM	REVISION	RECORD	AUTH.	DR.	CK.
10/05	-	INITIAL RELEASE		.	WJR	
7/10	A	PLUNGER WAS SST		1046	WJR	
3/12	B	PLUNGER MAT.; RM IRIDIUM		.	DBD	

TIME DELAY  
ADJUSTMENT SCREW

BRASS NUT INCLUDED  
(1/8" THICK)

PLUGABLE BLOCK  
3.81MM PITCH

TERMINAL HEADER

15/32-32 2A THD

.115 TRAVEL

1 1/2

2 3/16

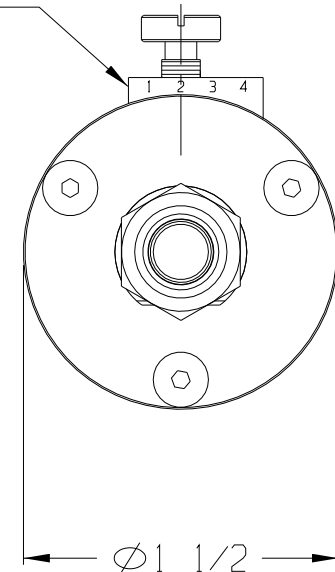
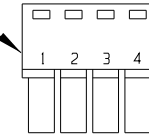

- ④ 4. CONSTRUCTION: 6026 ALUMINUM HOUSING;  
STAINLESS STEEL PLUNGER.
3. FORM Z CONTACT CONFIGURATION
2. SWITCH: 5 AMP 125 VAC
- NOTES: 1. TERMINAL PINS 1 & 3 N.O.  
PINS 2 & 4 N.C.

TOLERANCES

( EXCEPT AS  
NOTED )

DECIMAL

± -

FRACTIONAL

± -

ANGULAR

± -

**HIGHPOWER**

SECURITY PRODUCTS, LLC

290 PRATT STREET, 4TH FLOOR, MERIDEN, CT 06450

FORM "Z" TERMINAL  
PNEUMATIC SWITCH

SCALE  
1:1

DRWN.  
WJR

APPR.

DATA SHEET - PNEUMATIC SWITCH, FORM Z

DATE

10/26/05

DRAWING NUMBER

750-2000

REV.

B

DATE	SYM	REVISION RECORD	AUTH.	DR.	CK.
5/09	-	INITIAL RELEASE	-	WJR	

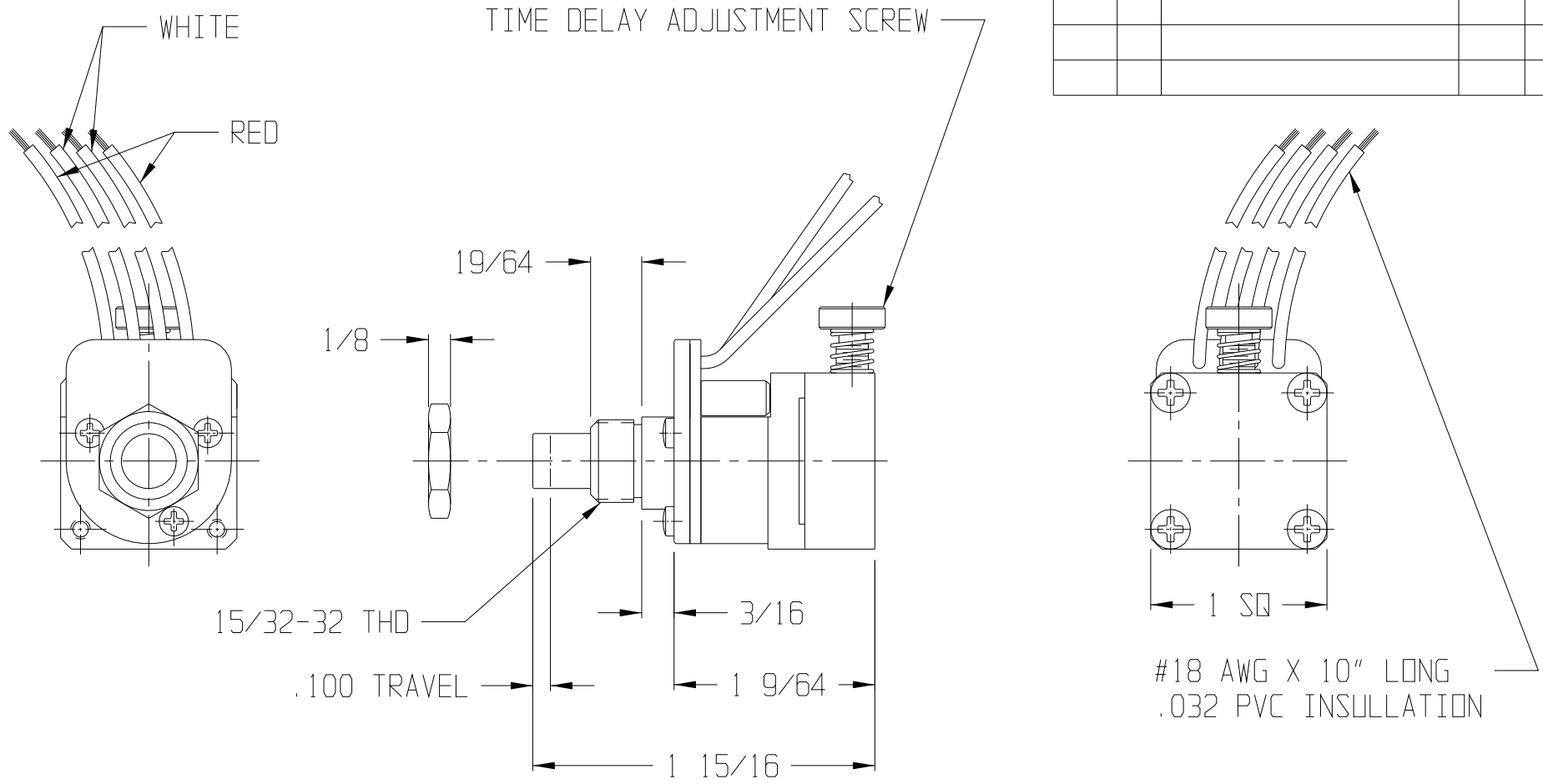

- 5. TIMING REPEATABILITY TOLERANCE ±10% AT CONSTANT TEMPERATURE.
  - 4. CONSTRUCTION: 6026 ALUMINUM HOUSING; STAINLESS STEEL PLUNGER; BRASS ADJ SCREW.
  - 3. FORM Z CONTACT CONFIGURATION
  - 2. SWITCH: 5 AMP 125 VAC
- NOTES: 1. WIRES: #18 AWG X 10" LG, 2 WHITE (N.O.)  
2 RED (N.C.).

TOLERANCES (EXCEPT AS NOTED)
DECIMAL ± .010
FRACTIONAL ± 1/64
ANGULAR ± -

290 PRATT STREET, 4TH FLOOR, MERIDEN, CT 06450

MINIATURE FORM Z PNEUMATIC TIMER	SCALE 1:1	DRWN. WJR	APPR.
DATA SHEET- PNEUMATIC TIMER			
DATE 5/5/09	DRAWING NUMBER 750-4000		REV. 5/5/09

DATE	SYM	REVISION RECORD	AUTH.	DR.	CK.
5/09	-	INITIAL RELEASE	-	WJR	

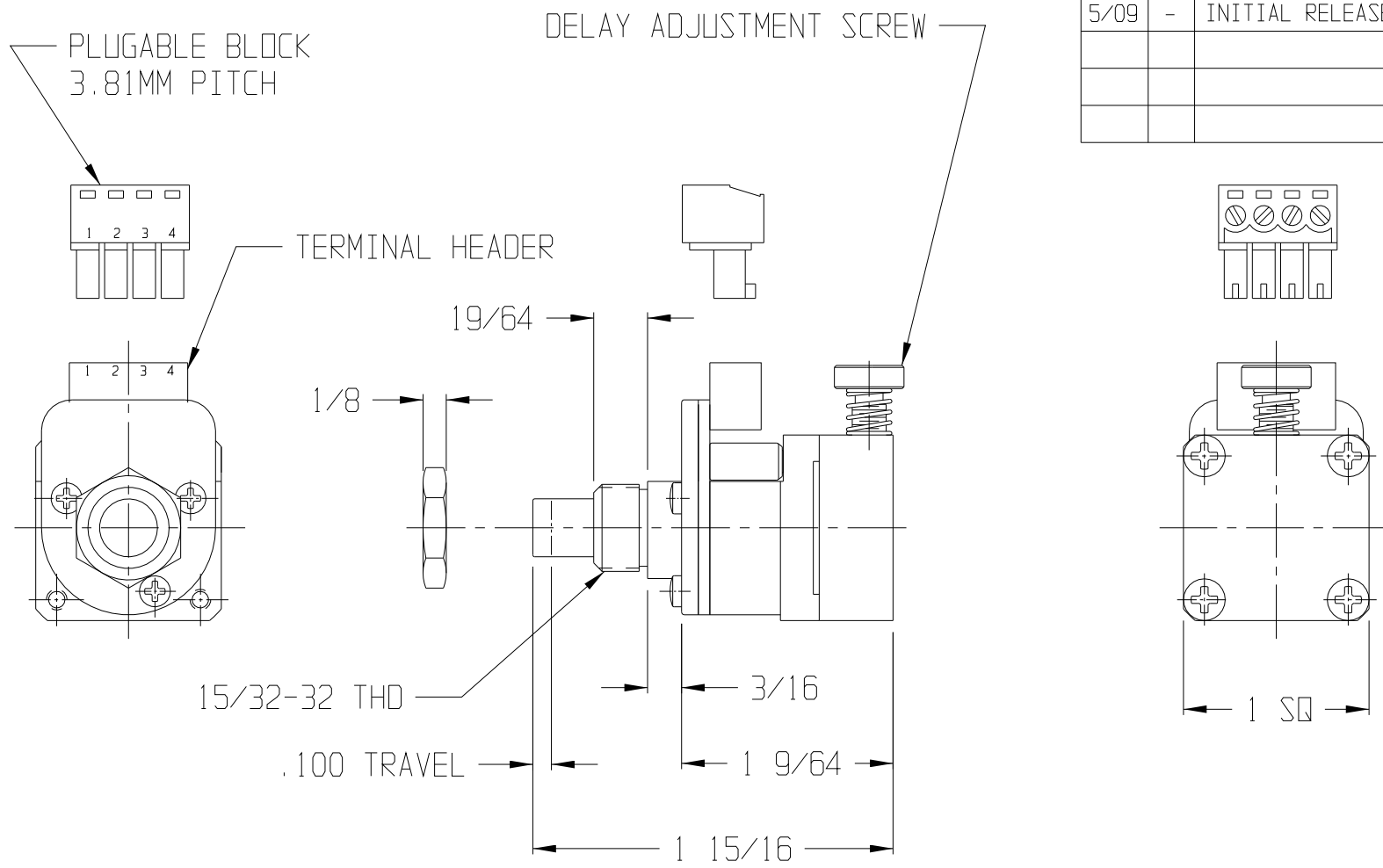

- 5. TIMING REPEATABILITY TOLERANCE  $\pm 10\%$  AT CONSTANT TEMPERATURE.
- 4. CONSTRUCTION: 6026 ALUMINUM HOUSING; STAINLESS STEEL PLUNGER; BRASS ADJ SCREW.
- 3. FORM Z CONTACT CONFIGURATION
- 2. SWITCH: 5 AMP 125 VAC
- NOTES: 1. TERMINAL PINS 2 & 3 N.O. PINS 1 & 4 N. C.

TOLERANCES (EXCEPT AS NOTED)
DECIMAL $\pm .010$
FRACTIONAL $\pm 1/64$
ANGULAR $\pm -$

**HIGHPOWER**  
SECURITY PRODUCTS, LLC

290 PRATT STREET, 4TH FLOOR, MERIDEN, CT 06450

MINIATURE FORM Z PNEUMATIC TIMER	SCALE 1:1	DRWN. WJR	APPR.
DATA SHEET PNEUMATIC TIMER (TERMINAL BLOCK)			
DATE 5/7/09	DRAWING NUMBER 750-4100		REV. 5/7/09