

6

5

4

3

2

1

APPROVED: _____

DATE: _____ TITLE: _____

Rev	AWO #	Description	Date	Appr
-		RELEASED	3/3/16	

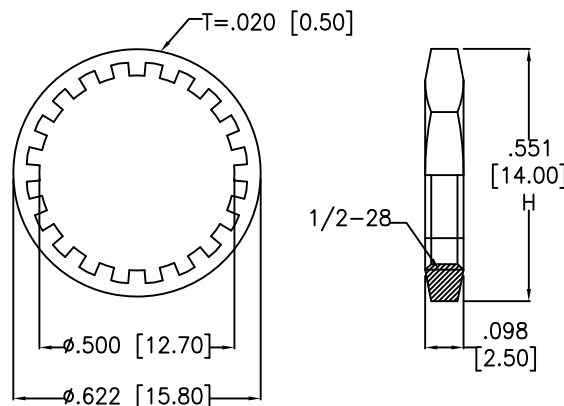
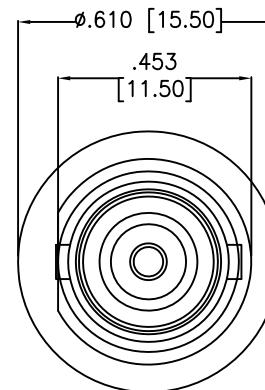
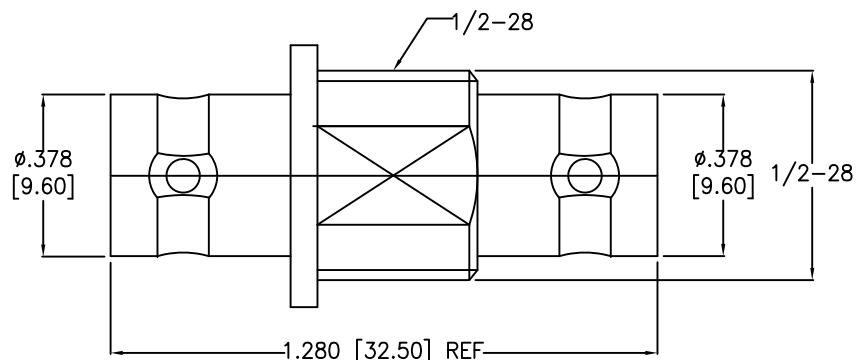

NUT	ZINC	NICKEL
WASHER	IRON	NICKEL
PRESS IT WASHER	IRON	NICKEL
CENTER PIN	BRASS	GOLD
DIELECTRIC	DELIN	NONE
BODY	ZINC	NICKEL
DESCRIPTION	MATERIAL	FINISH

SPECIFICATIONS:

Electrical:
 Nominal Impedance: 50 ohm
 Frequency range: 0-4 GHz
 Contact Resistance: 3 Milliohms max. (Center Contact)
 2 Milliohms max. (Outer Contact)
 Insulator Resistance: 5,000 Megohms min.
 Environmental:
 Lead free, RoHS compliant.



UNLESS OTHERWISE SPECIFIED
 ALL DIMENSIONS ARE INCHES [MM]
 TOLERANCES: EXCEPT AS NOTED
 INCHES HOLES

.X ± .10	∅X ± .10
.XX ± .020	∅XX ± .015
.XXX ± .015	∅XXX ± .010

ADAM TECH

909 Rahway Avenue, Union, NJ 07083
 Phone: 908-687-5000 Fax: 908-687-5710

APPROVALS		DATE	TITLE	
DRAWN	AY	3/3/16	BNC DOUBLE FEMALE BULKHEAD ADAPTOR 50 OHM	
CHECKED	TW	3/3/16	SIZE	PART NO.
APPROVED			X	RF1-44-D-AS-50-HDW
REF: S00049T		SCALE: NTS	SHEET 1 OF 1	

6

5

4

3

2

1