

# **BQ25883 QFN boost-mode battery charger evaluation module**

This user's guide provides detailed testing instructions for the BQ25883 evaluation module (EVM). Also included are descriptions of the necessary equipment, equipment setup, procedures, the printed-circuit board layouts, schematics, and the bill of materials (BOM).

Throughout this user's guide, the abbreviations *EVM*, *BQ25883EVM*, *BMS016*, and the term *evaluation module* are synonymous with the BQ25883 QFN evaluation module, unless otherwise noted.

## Contents

1	Introduction .....	2
1.1	EVM Features .....	2
1.2	I/O Descriptions .....	2
2	Test Summary .....	4
2.1	Equipment .....	4
2.2	Charge Mode .....	5
2.3	OTG Mode .....	8
2.4	Helpful Tips .....	10
3	PCB Layout Guidelines .....	10
4	Board Layout, Schematic, and Bill of Materials .....	11
4.1	Board Layout .....	11
4.2	Schematic .....	12
4.3	Bill of Materials .....	13

## List of Figures

1	BQ25883 Charge Mode Test Setup .....	5
2	Charge Mode Startup .....	7
3	BQ25883 OTG Mode Test Setup .....	8
4	OTG Mode Startup .....	9
5	BQ2588xEVM Top Overlay .....	11
6	BQ2588xEVM Layer 2 .....	11
7	BQ2588xEVM Layer 3 .....	11
8	BQ2588xEVM Bottom Overlay .....	11
9	BQ25883EVM Schematic .....	12

## List of Tables

1	Device Data Sheets .....	2
2	EVM Connections .....	2
3	EVM Jumper Connections and Shunt Installation .....	3
4	Recommended Operating Conditions .....	3
5	BQ25883EVM .....	13

## Trademarks

Microsoft, Windows are registered trademarks of Microsoft Corporation. All other trademarks are the property of their respective owners.

## 1 Introduction

As industry improvements continue to make portable electronics more powerful, their power requirements increase. Using two series Li-Ion polymer cells is one way to achieve this power increase. Charging these 8.4-V battery packs from a legacy 5-V USB port requires a boost charger. The BQ25883 is a highly-integrated 2-A boosting, 1.5-MHz switch-mode battery charge management device for a 2s Li-Ion and Li-polymer battery. BQ25883 integrates Power Path management with I<sup>2</sup>C serial interface which makes the device a truly flexible solution with charging and system settings.

### 1.1 EVM Features

The BQ25883 QFN evaluation module (EVM) is a complete charger module for evaluating the I<sup>2</sup>C-controlled, 2s battery NVDC charger in the QFN package. Key features of this EVM include:

- Easily evaluate the high-efficiency 2-A, 1.5-MHz integrated field-effect-transistor (FET), switch-mode boost charger in the QFN package
- Use of an onboard USB input adapter for connecting to a USB source and either communication through D+/D– to set the default input current limit
- Use the EV2400 interface to program parameters for charge operation as well as monitor voltages and current with an integrated analog-to-digital converter (ADC)
- Onboard test points, sense resistors, and jumpers facilitate measurement of high-efficiency- and high-accuracy voltage and current regulation

See the device data sheet ([Table 1](#)) for detailed features and operation of the integrated circuit (IC).

**Table 1. Device Data Sheets**

Device	Data Sheet	EVM Label	Variant
BQ25883	<a href="#">SLUSDL3</a>	BQ25883EVM-004	004

This EVM does **not** include the EV2400 interface board. To evaluate the EVM, order an EV2400 interface board separately.

### 1.2 I/O Descriptions

[Table 2](#) lists the jumper connections available on this EVM.

**Table 2. EVM Connections**

Jack	Description
J1(2)–VBUS	Connection for positive terminal of charger power source
J1(1)–GND	Connection for negative terminal (ground terminal) of charger power source
J2(1)–SYS	Connection to system load
J2(2)–GND	Ground
J3(1)–PMID	PMID pin connection
J3(2)–GND	Ground
J4(1)–BAT+	Connection for battery pack positive node to BAT pin
J4(2)–TOP- /BOT+	Connection for the mid connection point of the top and bottom cell (BQ25887only. Do not use for BQ25883 or BQ25886)
J5(1)–GND	Connection to battery pack negative node = EVM ground
J5(2)–TS	Connection for the NTC thermistor
J6	I <sup>2</sup> C 4-pin connector for EV2400
J7	Input mini-USB port

Table 3 lists the EVM jumper connections.

**Table 3. EVM Jumper Connections and Shunt Installation**

Jack	Description	BQ25883 Setting
JP1	STAT, $\overline{\text{PG}}$ , $\overline{\text{CE}}$ , $\overline{\text{INT}}$ , SDA, and SCL pins 3.3-V LDO pullup source of either SYS (pin 1 to 2) or BAT (pin 2 to 3)	Shunt pins 2 and 3
JP2	ILIM pin connection to resistor to GND	Installed
JP3	Connects D+ pin to pin 3 of J5 mini-USB port	installed
JP4	DNI	NA
JP5	TS resistor divider pullup source (REGN) connection	Installed
JP6	Connects D– pin to pin 2 of J5 mini-USB port	Installed
JP7	Connects an onboard 10 k $\Omega$ from TS pin to GND	Installed
JP8	DNI	NA
JP9	$\overline{\text{CE}}$ pin to GND	NA
JP10	Pulls up STAT through diode and resistor to pullup source	Installed
JP11	Pulls up $\overline{\text{PG}}$ through diode and resistor to pullup source	Shunt pins 2 and 1
JP12	Pull up SDA through 10-k $\Omega$ resistor; optional if I2C line has internal pullup.	Shunt pins 2 and 1
JP13	Pull up SCL through 10-k $\Omega$ resistor; optional if I2C line has internal pullup.	Installed
JP14	Pull up $\overline{\text{INT}}$ through 10-k $\Omega$ resistor	Installed
JP15	$\overline{\text{CE}}$ pin through 10-k $\Omega$ resistor	Open

Table 4 lists the recommended operating conditions for this EVM.

**Table 4. Recommended Operating Conditions**

Symbol	Description	MIN	TYP	MAX	Unit
Supply voltage, $V_{\text{VBUS}}$	Input voltage from AC adapter	3.9	5	6.5	V
Battery voltage, $V_{\text{BAT}}$ in charge mode	Voltage applied at $V_{\text{BAT}}$ terminal	0 or floating	8.4	9.2	V
Battery voltage, $V_{\text{BAT}}$ in OTG mode	Voltage applied at $V_{\text{BAT}}$ terminal	5.85	—	9.2	V
$I_{\text{BAT}}$	Fast charging current	0	—	2.2	A
	Discharging current through internal MOSFET	6	—	—	A
Supply current, $I_{\text{IN}}$	Maximum input current from AC adapter input	0	—	3.3	A

## 2 Test Summary

### 2.1 Equipment

This section includes a list of supplies required to perform tests on this EVM.

1. *Power supply (PS#1)* : The power supply must be capable of supplying up to 6.5 V at 3.3 A. While this part can handle larger voltage and current, it is not necessary for this procedure.
2. *Battery simulator (BS#1)* : Four-quadrant supply set to constant voltage  $\leq 9.2$  V  
Example: Kepco Bipolar Power Supply: BOP 20–5M, DC 0 to  $\pm 20$  V, 0 to  $\pm 5$  A (or higher) and Keithley 2420 Sourcemeter
3. *Load #1*: Electronic or resistive load capable of sinking up to 3 A at 9.2 V
4. *Meters*: Six Fluke 75 multimeters (equivalent or better)
  - Alternatively; four equivalent voltage meters and two equivalent current meters. The current meters must be capable of measuring greater than 3 A of current. A current meter in series with the battery or battery simulator must have auto-ranging disabled and should only be used for DC measurements (no start-up, transients, and so forth).
5. *Computer*: A computer with at least one USB port and a USB cable
6. *PC communication interface*: EV2400 USB-based PC interface board
7. *Software*: Download [bqStudio](#) from Texas Instruments  
Double click the *Battery management studio* installation file and then follow the installation steps. The software supports Microsoft® Windows® 7 and Windows 10 operating systems.

## 2.2 Charge Mode

### 2.2.1 Charge Mode Test Setup

Use the following list to set up the equipment for charge mode operation:

1. Figure 1 shows the test setup for BQ25883 when in charge (boosting) mode including jumper settings per Table 2. Ensure that the power supply and battery simulator are turned off before connecting to the EVM.

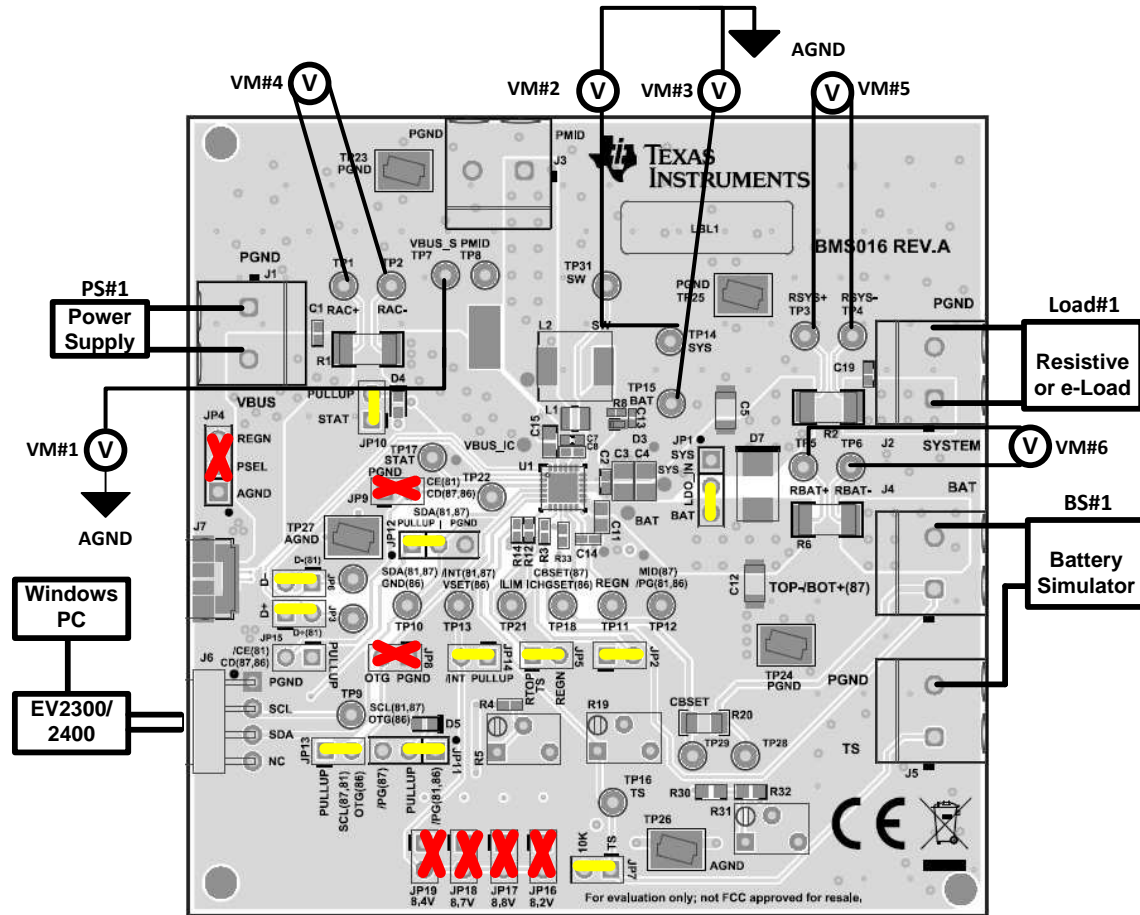

Figure 1. BQ25883 Charge Mode Test Setup

2. Voltmeters 1 through 3 (VM1, VM2, and VM3) connect to Kelvin test points for measuring VBUS, SYS, and BAT as close to the IC pins as possible. Voltmeters 4 through 6 measure the voltage across 0.01  $\Omega$ , which gives the current.
3. Before attaching to the EVM, set battery simulator 1 (BS#1) no higher than 7.6 V and at a 2.5-A current limit and set power supply 1 (PS#1) for 5.5 V and a 3.5-A current limit.
4. Turn off BS#1 and PS#1 then attach BS#1 to the BAT (J4) and PGND(J5) terminal of the EVM and attach PS#1 to J1 (VBUS, GND) of the EVM.
5. For BQ25883, optionally, turn off an electronic load and attach to the J2 (SYS, GND) terminal of the EVM.
6. With the EV2400 connected to the PC and the EVM, launch *Battery Management Studio* (bqStudio). Select *Charger* and the BQ25881 evaluation software.

## 2.2.2 Charge Mode I2C Register Setup

### 2.2.2.1 BQ25883EVM

1. Turn on BS#1 and set for 7.6 V.
2. In the EVM software, specify the "I2C Address" as *D6 (6B)*.

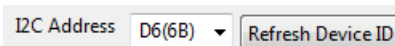

I2C Address D6(6B) Refresh Device ID

3. Click the *Read* button.
4. In the EVM GUI software *Field View*, ensure that the following I<sup>2</sup>C registers have the following settings:
  - Chose "Disabled" in the drop-down box for the *Watchdog Timer*
  - *Input Voltage Limit*= "4.4V" (default)
  - *Input Current Limit*= "3.3A"
  - *Charge Voltage Limit*= "8.40V" (default)
  - *Fast Charge Current Limit*= "1.00A"
  - *Pre-charge Current Limit* to "0.15A" (default)
  - *Minimum System Voltage* to "7.0V" (default)
  - Deselect *Enable Charge* to disable charge
  - Deselect *Enable ILIM pin* to disable the ILIM pin
  - Deselect *Enable HiZ*, if selected
5. Click *Read Register* to confirm that register changes were made.

## 2.2.3 Charge Mode Test Procedure

Use the following steps for charge mode verification and testing:

1. Turn on PS#1 and click the *Read Register* button twice.
  - *Observe* → everything "Normal" at the *Fault* box
  - *Observe* → D4 (STAT) is off because charge is disabled.
  - *Observe* → D5 ( $\overline{PG}$ ) is on indicating power is good.
  - *Measure on VM2* → V(TP14 (SYS), TP26 (AGND)) = 6.4 V  $\pm$ 50 mV
2. On BQ25883EVM, use the GUI to select *Enable Charge* to start charging at 1.0 A. To correct for cable resistance, adjust PS#1 until VM1 [TP7 (VBUS\_S), TP26 (AGND)] measures 5.5 V  $\pm$ 50 mV and adjust BS#1 until VM3 [TP15 (BAT), TP26 (AGND)] measures 7.6 V  $\pm$ 50 mV.
  - *Measure on VM6* → V(TP5 (RBAT+), TP6 (RBAT-)) = 10 mV  $\pm$ 0.7 mV which corresponds to ICHG = 1.0 A  $\pm$ 5% through a 0.010- $\Omega$   $\pm$ 1% resistor. Voltage of 0.1 mV is added to account for DMM accuracy.
  - *Measure on VM4* → V(TP1 (RAC+), TP2 (RAC-)) = 14.8 mV  $\pm$ 0.7 mV which corresponds to IVBUS = 1.48 A  $\pm$ 5% (accounting for efficiency variation across ICs and inductors) through a 0.010- $\Omega$   $\pm$ 1% resistor. Voltage of 0.1 mV is added to account for DMM accuracy.
3. Optionally, in the GUI, select *Enable ILIM pin*. Adjust the RLIM potentiometer (R5) until:
  - *Measure on VM4* → V(TP1 (RAC+), TP2 (RAC-)) = 10 mV  $\pm$ 0.7 mV which corresponds to IVBUS = 1.0 A  $\pm$ 5% through a 0.010- $\Omega$   $\pm$ 1% resistor. Voltage of 0.1 mV is added to account for DMM accuracy.
  - *Obverse in bqStudio after Read Register* → IINDPM Status: In IINDPM
4. Turn off and disconnect PS#1, BS#1, Load#1, and voltmeters.

### 2.2.4 Charge Mode Evaluation Results

Figure 2 shows the *Charge Mode Startup* graph.

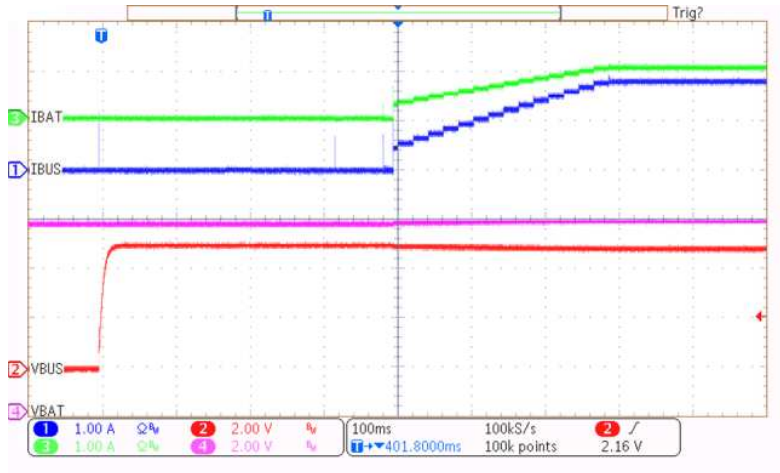

Figure 2. Charge Mode Startup

## 2.3 OTG Mode

### 2.3.1 OTG Mode Test Setup

Use the following list to set up the equipment for boost mode operation:

1. Ensure that the electronic load and battery simulator are turned off when connecting to the EVM. [Figure 3](#) shows the test setup for BQ25883 when in OTG mode, including the jumper settings per [Table 2](#).

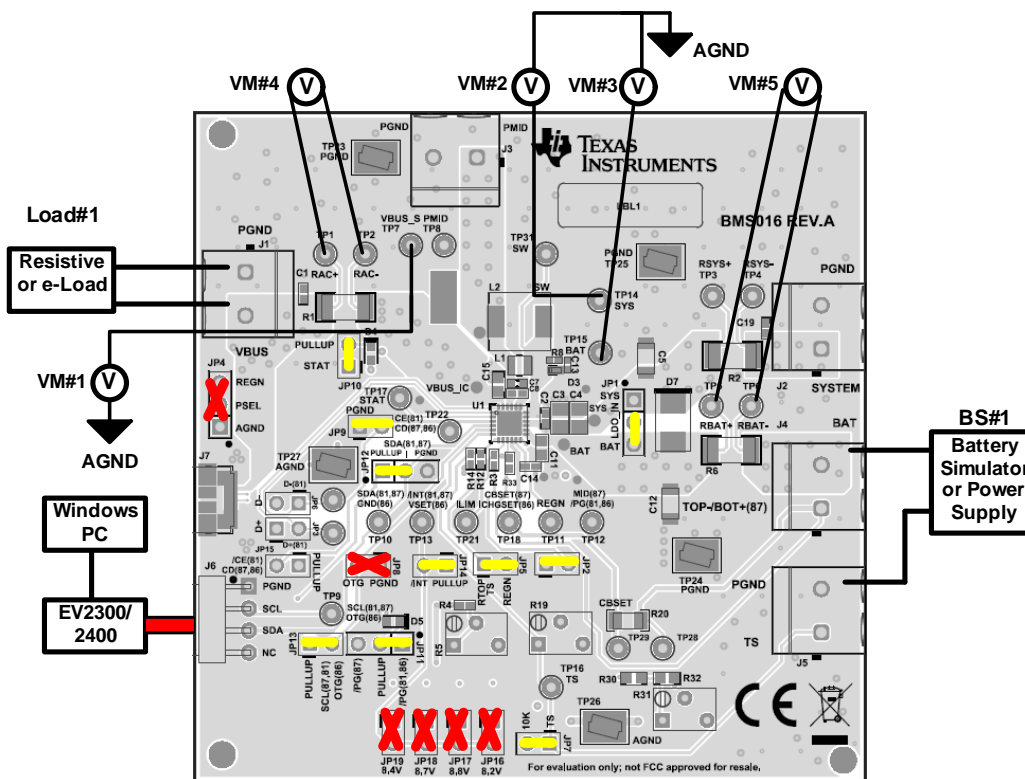

**Figure 3. BQ25883 OTG Mode Test Setup**

2. Voltmeters 1 through 3 (VM1, VM2, and VM3) connect to Kelvin test points for measuring VBUS, SYS, and BAT as close to the IC pins as possible. Voltmeters 4 through 5 measure the voltage across 0.01  $\Omega$ , which gives the current.
3. Set BS#1 to 7.6 V and at a 6-A current limit, then turn off BS#1 and attach to the J4 (BAT, GND) terminal of the EVM.
4. With electronic load disabled, attach to the J1 (VBUS, GND) terminal of the EVM.
5. With the EV2400 connected to the PC and the EVM, launch *Battery Management Studio* (bqStudio). Select *Charger* and the BQ25883 evaluation software.



### 2.3.2 OTG Mode I2C Register Setup

1. Turn on BS#1, set for 7.6 V.
2. In the EVM software, specify the "I2C Address" as *D6 (6B)*.

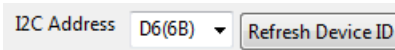

3. Click the *Read* button.
4. In the EVM GUI software *Field View* ensure that the following I<sup>2</sup>C registers have the following settings:
  - Chose "Disabled" for the *Watchdog Timer*
  - *OTG Voltage Limit*= "5.0 V"
  - *OTG Current Limit*= "600 mA"
  - Deselect *Enable Charge*
  - Deselect *Enable HiZ* if selected
  - Select *Enable OTG*

### 2.3.3 OTG Mode Test Procedure

Use the following steps for boost mode verification:

1. *Observe* → everything "Normal" at the *Fault* box
2. *Measure on VM2* → V(TP1 (VBUS), TP26 (AGND)) = 5.0 V ±160 mV. Voltage of 10 mV is added to account for DMM accuracy.
3. Set electronic load in CC mode to 500 mA, or resistive load to 10 Ω.
4. *Measure on VM2* → V(TP1 (VBUS), TP26 (AGND)) = 5.0 V ±160 mV. Voltage of 10 mV is added to account for DMM accuracy.
5. Turn off and disconnect BS#1, Load#1, and voltmeters.

### 2.3.4 OTG Mode Evaluation Results

Figure 4 shows the *OTG Mode Startup* graph.

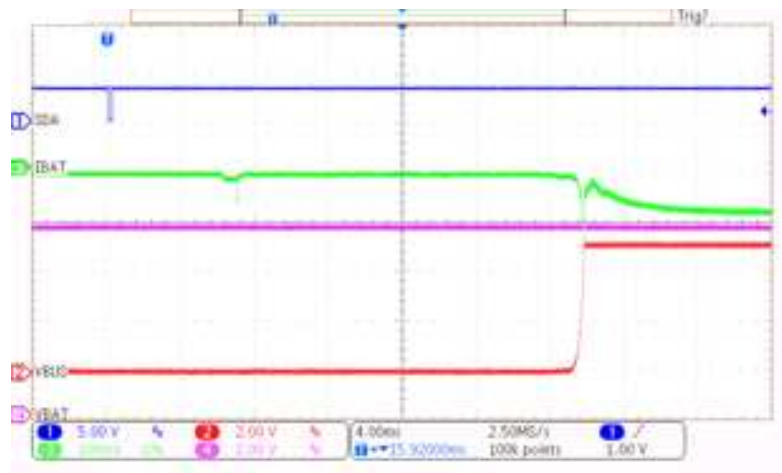

Figure 4. OTG Mode Startup

## 2.4 Helpful Tips

The following list provides a few helpful tips:

- The leads and cables to the various power supplies, batteries, and loads have resistance. The current meters also have series resistance. The charger dynamically reduces charge current depending on the voltage sensed at its VBUS pin (using the VINDPM feature), BAT pin (as part of normal termination), and TS pin (through its battery temperature monitoring feature through the battery thermistor). Therefore, the designer must use voltmeters to measure the voltage as close to the IC pins (TP7, TP15, and TP16) as possible instead of relying on the digital readouts of the power supply.
- When using a source meter that can source and sink current as the battery simulator, TI highly recommends adding a large (1000  $\mu$ F or greater) capacitor at the EVM BAT and GND connectors to prevent oscillations at the BAT pin, which are due to mismatched impedances of the charger output and source meter input within their respective regulation loop bandwidths. Configuring the source meter for four-wire sensing eliminates the requirement for a separate voltmeter to measure the voltage at the BAT pin. When using four-wire sensing, always ensure that the sensing leads are connected to prevent accidental overvoltage by the power supply.
- For precise measurements of efficiency and charge current or battery regulation (or both) near termination, a current meter in series with the battery or battery simulator must not be set to auto-range and may require removal, entirely. This EVM offers an alternate method for measuring currents by measuring the voltage across a 1%, thermally-capable (for example, 0.010  $\Omega$  in a 1210 or larger footprint) resistor in series between the power sources and power pins.

## 3 PCB Layout Guidelines

Minimize the switching node rise and fall times for minimum switching loss. Proper layout of the components that minimize the high-frequency current path loop is important to prevent electrical and magnetic field radiation and high-frequency resonant problems. To ensure proper layout, follow the priority list for this printed-circuit board (PCB) in the order presented:

1. Place the output capacitor as close as possible to the SYS pin and GND pin connections and use the shortest copper trace connection or GND plane.
2. Put the input capacitors near to the VBUS and PMID pins. Tie ground connections to the IC ground with a short copper trace connection or GND plane.
3. Place the inductor input terminal as close to the SW pin as possible. Minimize the copper area of this trace to lower electrical and magnetic field radiation but make the trace wide enough to carry the charging current. Do not use multiple layers in parallel for this connection. Minimize parasitic capacitance from this area to any other trace or plane.
4. Route analog ground separately from power ground. Connect analog ground and connect power ground separately. Connect analog ground and power ground together using the power pad as the single ground connection point or use a 0- $\Omega$  resistor to tie analog ground to power ground.
5. Use a single ground connection to tie the charger power ground to the charger analog ground just beneath the IC. Use ground copper pour but avoid power pins to reduce inductive and capacitive noise coupling.
6. Place decoupling capacitors next to the IC pins and make the trace connection as short as possible.
7. One critical note regarding the layout is that the exposed power pad on the backside of the IC package must be soldered to the PCB ground. Ensure that there are sufficient thermal vias directly under the IC connecting to the ground plane on the other layers.
8. The via size and number must be sufficient for a given current path.

See the EVM design for the recommended component placement with trace and via locations..

## 4 Board Layout, Schematic, and Bill of Materials

### 4.1 Board Layout

Figure 5 through Figure 8 show the PCB board layouts.

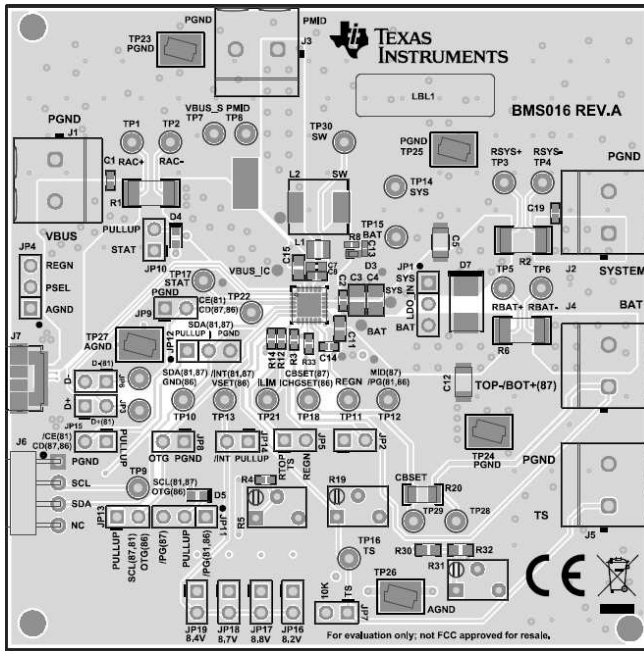

Figure 5. BQ2588xEVM Top Overlay

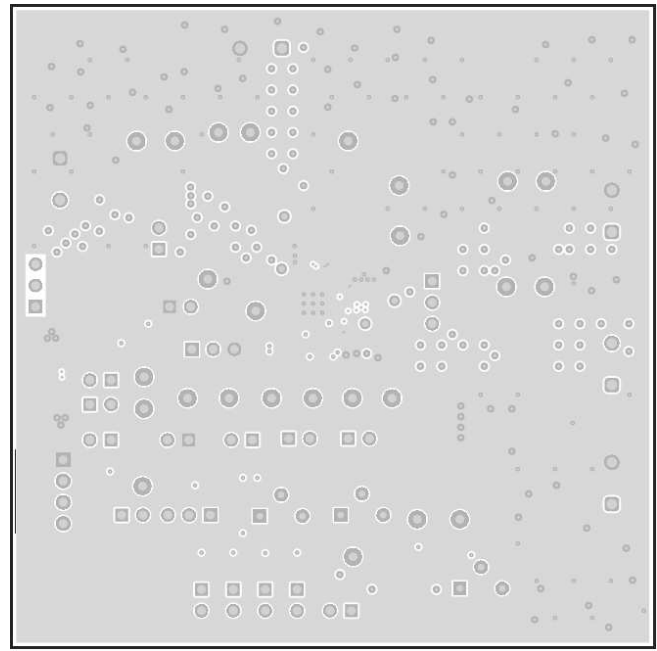

Figure 6. BQ2588xEVM Layer 2

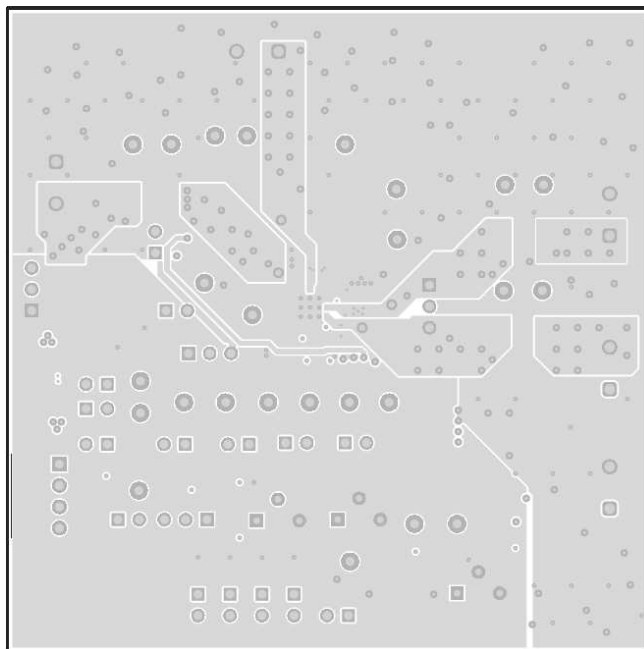

Figure 7. BQ2588xEVM Layer 3

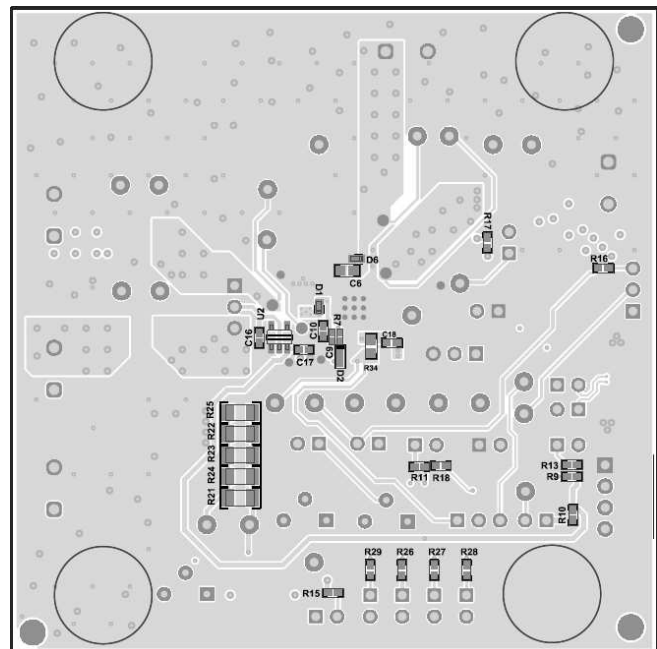

Figure 8. BQ2588xEVM Bottom Overlay

## 4.2 Schematic

Figure 9 shows the schematic for the BQ2588x QFN EVM.

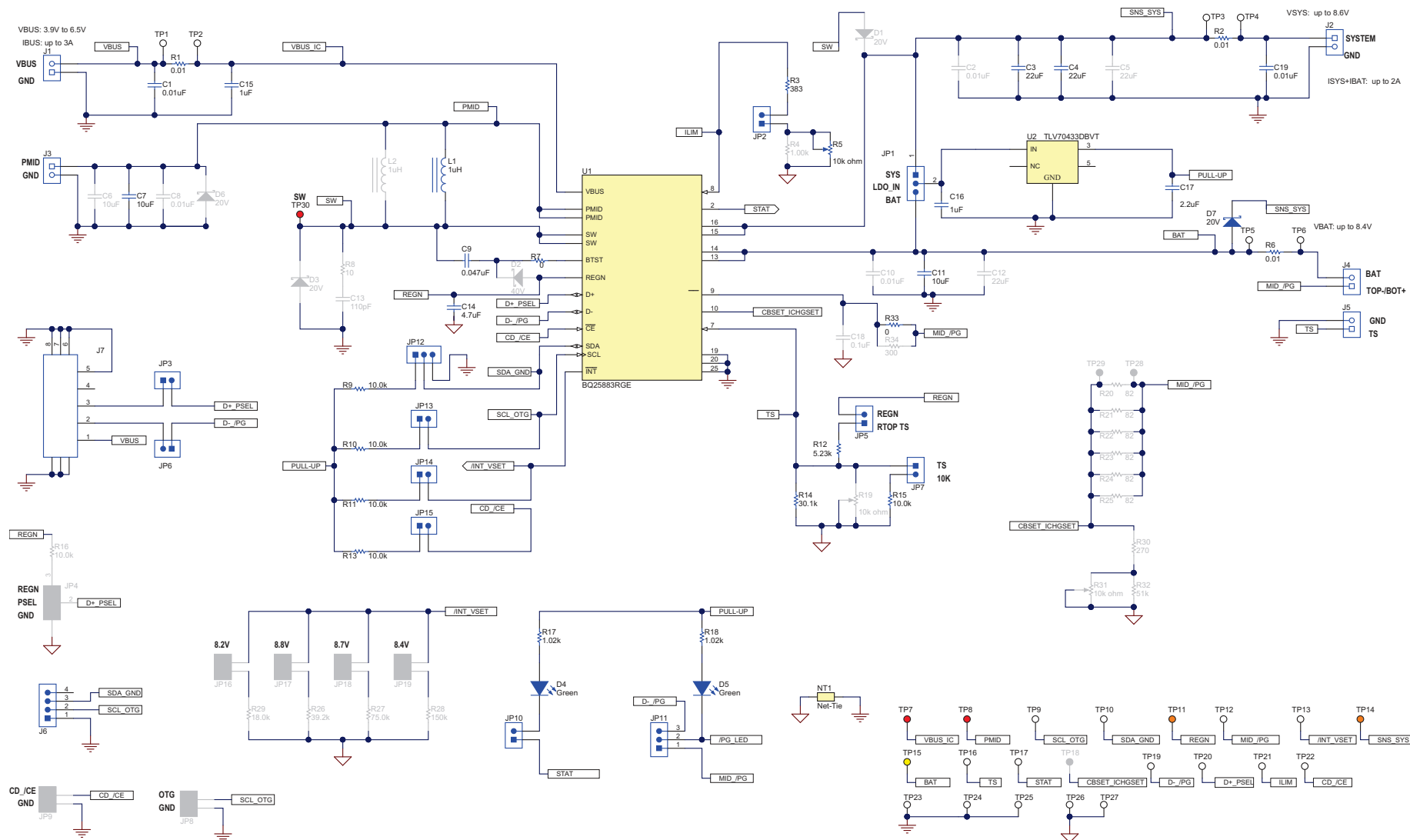

Figure 9. BQ25883EVM Schematic

### 4.3 Bill of Materials

Table 5 lists the BQ25883EVM BOM.

**Table 5. BQ25883EVM<sup>(1)</sup>**

Designator	Quantity	Value	Description	PackageReference	PartNumber	Manufacturer	Alternate PartNumber	Alternate Manufacturer
!PCB	1		Printed Circuit Board		BMS016	Any	-	-
C1	1	0.01uF	CAP, CERM, 0.01 uF, 25 V, +/- 10%, X7R, 0402	0402	GCM155R71E103 KA37D	MuRata		
C3, C4	2	22uF	CAP, CERM, 22 uF, 25 V, +/- 20%, X5R, 0805	0805	GRM21BR61E226 ME44L	MuRata		
C7, C11	2	10uF	CAP, CERM, 10 uF, 25 V, +/- 20%, X5R, 0603	0603	GRM188R61E106 MA73D	MuRata		
C9	1	0.047uF	CAP, CERM, 0.047 uF, 25 V, +/- 10%, X7R, 0402	0402	GRM155R71E473 KA88D	MuRata		
C14	1	4.7uF	CAP, CERM, 4.7 uF, 10 V, +/- 20%, X5R, 0402	0402	GRM155R61A475 MEAAD	MuRata		
C15	1	1uF	CAP, CERM, 1 uF, 25 V, +/- 10%, X5R, 0603	0603	C1608X5R1E105K 080AC	TDK		
C16	1	1uF	CAP, CERM, 1 uF, 16 V, +/- 10%, X5R, 0402	0402	EMK105BJ105KVHF	Taiyo Yuden		
C17	1	2.2uF	CAP, CERM, 2.2 uF, 10 V, +/- 20%, X5R, 0402	0402	GRM155R61A225 ME95	MuRata		
C19	1	0.01uF	CAP, CERM, 0.01 uF, 25 V, +/- 10%, X7R, 0402	0402	GRM155R71E103 KA01D	MuRata		
D4, D5	2	Green	LED, Green, SMD	1.6x0.8x0.8mm	LTST-C190GKT	Lite-On		
D7	1	20V	Diode, Schottky, 20 V, 3 A, SMB	SMB	B320B-13-F	Diodes Inc.		

<sup>(1)</sup> Unless otherwise noted in the Alternate PartNumber and/or Alternate Manufacturer columns, all parts may be substituted with equivalents.

Table 5. BQ25883EVM<sup>(1)</sup> (continued)

Designator	Quantity	Value	Description	PackageReference	PartNumber	Manufacturer	Alternate PartNumber	Alternate Manufacturer
H9, H10, H11, H12	4		Bumpon, Hemisphere, 0.44 X 0.20, Clear	Transparent Bumpon	SJ-5303 (CLEAR)	3M		
J1, J2, J3, J4, J5	5		Terminal Block, 5mm, 2x1, R/A, TH	Terminal Block, 5mm, 2x1, R/A, TH	1792863	Phoenix Contact		
J6	1		Header (friction lock), 100mil, 4x1, R/A, TH	4x1 R/A Header	22/05/3041	Molex		
J7	1		Connector, Receptacle, Micro-USB Type B, R/A, Bottom Mount SMT	7.5x2.45x5mm	473460001	Molex		
JP1, JP11, JP12	3		Header, 100mil, 3x1, Tin, TH	Header, 3 PIN, 100mil, Tin	PEC03SAAN	Sullins Connector Solutions		
JP2, JP3, JP5, JP6, JP7, JP10, JP13, JP14, JP15	9		Header, 100mil, 2x1, Tin, TH	Header, 2 PIN, 100mil, Tin	PEC02SAAN	Sullins Connector Solutions		
L1	1	1uH	Inductor, Shielded, Metal Composite, 1 uH, 3.3 A, 0.04 ohm, SMD	2.5x1.2x2mm	DFE252012F-1R0M=P2	MuRata Toko		
LBL1	1		Thermal Transfer Printable Labels, 0.650" W x 0.200" H - 10,000 per roll	PCB Label 0.650 x 0.200 inch	THT-14-423-10	Brady		
R1, R2, R6	3	0.01	RES, 0.01, 1%, 1 W, 2010	2010	WSL2010R0100FE A18	Vishay-Dale		
R3	1	383	RES, 383, 1%, 0.063 W, AEC-Q200 Grade 0, 0402	0402	CRCW0402383RF KED	Vishay-Dale		
R5	1	10k ohm	Trimmer, 10k ohm, 0.25W, TH	4.5x8x6.7mm	3266W-1-103LF	Bourns		
R7	1	0	RES, 0, 5%, 0.063 W, 0402	0402	CRCW04020000Z0 ED	Vishay-Dale		
R9, R10, R11, R13, R15	5	10.0k	RES, 10.0 k, 1%, 0.063 W, 0402	0402	CRCW040210K0F KED	Vishay-Dale		
R12	1	5.23k	RES, 5.23 k, 1%, 0.063 W, 0402	0402	CRCW04025K23F KED	Vishay-Dale		
R14	1	30.1k	RES, 30.1 k, 1%, 0.063 W, 0402	0402	CRCW040230K1F KED	Vishay-Dale		

Table 5. BQ25883EVM<sup>(1)</sup> (continued)

Designator	Quantity	Value	Description	PackageReference	PartNumber	Manufacturer	Alternate PartNumber	Alternate Manufacturer
R17, R18	2	1.02k	RES, 1.02 k, 1%, 0.063 W, 0402	0402	CRCW04021K02FKED	Vishay-Dale		
R33	1	0	RES, 0, 5%, 0.063 W, 0402	0402	RC0402JR-070RL	Yageo America		
SH-JP1, SH-JP2, SH-JP3, SH-JP4, SH-JP5, SH-JP6, SH-JP7, SH-JP8, SH-JP9, SH-JP10, SH-JP11, SH-JP12, SH-JP13, SH-JP14, SH-JP15, SH-JP16	16	1x2	Shunt, 100mil, Gold plated, Black	Shunt	SNT-100-BK-G	Samtec	969102-0000-DA	3M
TP1, TP2, TP3, TP4, TP5, TP6, TP9, TP10, TP12, TP13, TP16, TP17, TP19, TP20, TP21, TP22	16		Test Point, Miniature, White, TH	White Miniature Testpoint	5002	Keystone		
TP7, TP8, TP30	3		Test Point, Miniature, Red, TH	Red Miniature Testpoint	5000	Keystone		
TP11, TP14	2		Test Point, Miniature, Orange, TH	Orange Miniature Testpoint	5003	Keystone		
TP15	1		Test Point, Miniature, Yellow, TH	Yellow Miniature Testpoint	5004	Keystone		
TP23, TP24, TP25, TP26, TP27	5		Test Point, Compact, SMT	Testpoint_Keystone_Compact	5016	Keystone		
U1	1		I2C Controlled, 2-Cell, 2A Boost-Mode Battery Charger for USB Input, RGE0024H (VQFN-24)	RGE0024H	BQ25883RGE	Texas Instruments		Texas Instruments
U2	1		Single Output LDO, 150 mA, Fixed 3.3 V Output, 2.5 to 24 V Input, with Ultra-Low IQ, 5-pin SOT-23 (DBV), -40 to 125 degC, Green (RoHS and no Sb/Br)	DBV0005A	TLV70433DBVT	Texas Instruments		

Table 5. BQ25883EVM<sup>(1)</sup> (continued)

Designator	Quantity	Value	Description	PackageReference	PartNumber	Manufacturer	Alternate PartNumber	Alternate Manufacturer
C2, C8, C10	0	0.01uF	CAP, CERM, 0.01 uF, 25 V, +/- 10%, X7R, 0402	0402	GRM155R71E103 KA01D	MuRata		
C5	0	22uF	CAP, CERM, 22 uF, 25 V, +/- 10%, X5R, 1206	1206	GRM31CR61E226 KE15L	MuRata		
C6	0	10uF	CAP, CERM, 10 uF, 25 V, +/- 20%, X5R, 0603	0603	GRM188R61E106 MA73D	MuRata		
C12	0	22uF	CAP, CERM, 22 uF, 25 V, +/- 10%, X5R, AEC-Q200 Grade 3, 1206	1206	GRT31CR61E226 KE01L	MuRata		
C13	0	110pF	CAP, CERM, 110 pF, 25 V, +/- 5%, C0G/NP0, 0402	0402	GRM1555C1E111J A01D	MuRata		
C18	0	0.1uF	CAP, CERM, 0.1 uF, 16 V, +/- 10%, X7R, 0402	0402	GCM155R71C104 KA55D	MuRata		
D1, D3, D6	0	20V	Diode, Schottky, 20 V, 1 A, 152AD	152AD	NSR10F20NXT5G	ON Semiconductor		
D2	0	40V	Diode, Schottky, 40 V, 0.38 A, SOD-523	SOD-523	ZLLS350TA	Diodes Inc.		
FID1, FID2, FID3, FID4, FID5, FID6	0		Fiducial mark. There is nothing to buy or mount.	N/A	N/A	N/A		
JP4	0		Header, 100mil, 3x1, Tin, TH	Header, 3 PIN, 100mil, Tin	PEC03SAAN	Sullins Connector Solutions		
JP8, JP9, JP16, JP17, JP18, JP19	0		Header, 100mil, 2x1, Tin, TH	Header, 2 PIN, 100mil, Tin	PEC02SAAN	Sullins Connector Solutions		
L2	0	1uH	Inductor, Shielded Drum Core, Powdered Iron, 1 uH, 11 A, 0.009 ohm, SMD	IHLP-2525CZ	IHLP2525CZER1R 0M01	Vishay-Dale		
R4	0	1.00k	RES, 1.00 k, 1%, 0.063 W, 0402	0402	CRCW04021K00F KED	Vishay-Dale		
R8	0	10	RES, 10, 5%, 0.063 W, 0402	0402	CRCW040210R0J NED	Vishay-Dale		
R16	0	10.0k	RES, 10.0 k, 1%, 0.063 W, 0402	0402	CRCW040210K0F KED	Vishay-Dale		



**Table 5. BQ25883EVM<sup>(1)</sup> (continued)**

Designator	Quantity	Value	Description	PackageReference	PartNumber	Manufacturer	Alternate PartNumber	Alternate Manufacturer
R19, R31	0	10k ohm	Trimmer, 10k ohm, 0.25W, TH	4.5x8x6.7mm	3266W-1-103LF	Bourns		
R20, R21, R22, R23, R24, R25	0	82	RES, 82, 5%, 0.25 W, AEC-Q200 Grade 0, 1206	1206	CRCW120682R0J NEA	Vishay-Dale		
R26	0	39.2k	RES, 39.2 k, 1%, 0.063 W, AEC-Q200 Grade 0, 0402	0402	CRCW040239K2F KED	Vishay-Dale		
R27	0	75.0k	RES, 75.0 k, 1%, 0.063 W, AEC-Q200 Grade 0, 0402	0402	CRCW040275K0F KED	Vishay-Dale		
R28	0	150k	RES, 150 k, 1%, 0.1 W, AEC-Q200 Grade 0, 0402	0402	ERJ-2RKF1503X	Panasonic		
R29	0	18.0k	RES, 18.0 k, 1%, 0.063 W, AEC-Q200 Grade 0, 0402	0402	CRCW040218K0F KED	Vishay-Dale		
R30	0	270	RES, 270, 5%, 0.1 W, 0603	0603	CRCW0603270RJ NEA	Vishay-Dale		
R32	0	51k	RES, 51 k, 5%, 0.1 W, 0603	0603	CRCW060351K0J NEA	Vishay-Dale		
R34	0	300	RES, 300, 1%, 0.1 W, 0603	0603	RC0603FR-07300RL	Yageo America		
TP18, TP28, TP29	0		Test Point, Miniature, White, TH	White Miniature Testpoint	5002	Keystone		



---

**IMPORTANT NOTICE AND DISCLAIMER**

TI PROVIDES TECHNICAL AND RELIABILITY DATA (INCLUDING DATASHEETS), DESIGN RESOURCES (INCLUDING REFERENCE DESIGNS), APPLICATION OR OTHER DESIGN ADVICE, WEB TOOLS, SAFETY INFORMATION, AND OTHER RESOURCES “AS IS” AND WITH ALL FAULTS, AND DISCLAIMS ALL WARRANTIES, EXPRESS AND IMPLIED, INCLUDING WITHOUT LIMITATION ANY IMPLIED WARRANTIES OF MERCHANTABILITY, FITNESS FOR A PARTICULAR PURPOSE OR NON-INFRINGEMENT OF THIRD PARTY INTELLECTUAL PROPERTY RIGHTS.

These resources are intended for skilled developers designing with TI products. You are solely responsible for (1) selecting the appropriate TI products for your application, (2) designing, validating and testing your application, and (3) ensuring your application meets applicable standards, and any other safety, security, or other requirements. These resources are subject to change without notice. TI grants you permission to use these resources only for development of an application that uses the TI products described in the resource. Other reproduction and display of these resources is prohibited. No license is granted to any other TI intellectual property right or to any third party intellectual property right. TI disclaims responsibility for, and you will fully indemnify TI and its representatives against, any claims, damages, costs, losses, and liabilities arising out of your use of these resources.

TI's products are provided subject to TI's Terms of Sale ([www.ti.com/legal/termsofsale.html](http://www.ti.com/legal/termsofsale.html)) or other applicable terms available either on [ti.com](http://ti.com) or provided in conjunction with such TI products. TI's provision of these resources does not expand or otherwise alter TI's applicable warranties or warranty disclaimers for TI products.

Mailing Address: Texas Instruments, Post Office Box 655303, Dallas, Texas 75265  
Copyright © 2019, Texas Instruments Incorporated

## STANDARD TERMS FOR EVALUATION MODULES

1. *Delivery:* TI delivers TI evaluation boards, kits, or modules, including any accompanying demonstration software, components, and/or documentation which may be provided together or separately (collectively, an "EVM" or "EVMs") to the User ("User") in accordance with the terms set forth herein. User's acceptance of the EVM is expressly subject to the following terms.
  - 1.1 EVMs are intended solely for product or software developers for use in a research and development setting to facilitate feasibility evaluation, experimentation, or scientific analysis of TI semiconductors products. EVMs have no direct function and are not finished products. EVMs shall not be directly or indirectly assembled as a part or subassembly in any finished product. For clarification, any software or software tools provided with the EVM ("Software") shall not be subject to the terms and conditions set forth herein but rather shall be subject to the applicable terms that accompany such Software
  - 1.2 EVMs are not intended for consumer or household use. EVMs may not be sold, sublicensed, leased, rented, loaned, assigned, or otherwise distributed for commercial purposes by Users, in whole or in part, or used in any finished product or production system.
2. *Limited Warranty and Related Remedies/Disclaimers:*
  - 2.1 These terms do not apply to Software. The warranty, if any, for Software is covered in the applicable Software License Agreement.
  - 2.2 TI warrants that the TI EVM will conform to TI's published specifications for ninety (90) days after the date TI delivers such EVM to User. Notwithstanding the foregoing, TI shall not be liable for a nonconforming EVM if (a) the nonconformity was caused by neglect, misuse or mistreatment by an entity other than TI, including improper installation or testing, or for any EVMs that have been altered or modified in any way by an entity other than TI, (b) the nonconformity resulted from User's design, specifications or instructions for such EVMs or improper system design, or (c) User has not paid on time. Testing and other quality control techniques are used to the extent TI deems necessary. TI does not test all parameters of each EVM. User's claims against TI under this Section 2 are void if User fails to notify TI of any apparent defects in the EVMs within ten (10) business days after delivery, or of any hidden defects with ten (10) business days after the defect has been detected.
  - 2.3 TI's sole liability shall be at its option to repair or replace EVMs that fail to conform to the warranty set forth above, or credit User's account for such EVM. TI's liability under this warranty shall be limited to EVMs that are returned during the warranty period to the address designated by TI and that are determined by TI not to conform to such warranty. If TI elects to repair or replace such EVM, TI shall have a reasonable time to repair such EVM or provide replacements. Repaired EVMs shall be warranted for the remainder of the original warranty period. Replaced EVMs shall be warranted for a new full ninety (90) day warranty period.

### **WARNING**

**Evaluation Kits are intended solely for use by technically qualified, professional electronics experts who are familiar with the dangers and application risks associated with handling electrical mechanical components, systems, and subsystems.**

**User shall operate the Evaluation Kit within TI's recommended guidelines and any applicable legal or environmental requirements as well as reasonable and customary safeguards. Failure to set up and/or operate the Evaluation Kit within TI's recommended guidelines may result in personal injury or death or property damage. Proper set up entails following TI's instructions for electrical ratings of interface circuits such as input, output and electrical loads.**

**NOTE:**

EXPOSURE TO ELECTROSTATIC DISCHARGE (ESD) MAY CAUSE DEGRADATION OR FAILURE OF THE EVALUATION KIT; TI RECOMMENDS STORAGE OF THE EVALUATION KIT IN A PROTECTIVE ESD BAG.

### 3 Regulatory Notices:

#### 3.1 United States

##### 3.1.1 Notice applicable to EVMs not FCC-Approved:

**FCC NOTICE:** This kit is designed to allow product developers to evaluate electronic components, circuitry, or software associated with the kit to determine whether to incorporate such items in a finished product and software developers to write software applications for use with the end product. This kit is not a finished product and when assembled may not be resold or otherwise marketed unless all required FCC equipment authorizations are first obtained. Operation is subject to the condition that this product not cause harmful interference to licensed radio stations and that this product accept harmful interference. Unless the assembled kit is designed to operate under part 15, part 18 or part 95 of this chapter, the operator of the kit must operate under the authority of an FCC license holder or must secure an experimental authorization under part 5 of this chapter.

##### 3.1.2 For EVMs annotated as FCC – FEDERAL COMMUNICATIONS COMMISSION Part 15 Compliant:

#### **CAUTION**

This device complies with part 15 of the FCC Rules. Operation is subject to the following two conditions: (1) This device may not cause harmful interference, and (2) this device must accept any interference received, including interference that may cause undesired operation.

Changes or modifications not expressly approved by the party responsible for compliance could void the user's authority to operate the equipment.

#### **FCC Interference Statement for Class A EVM devices**

*NOTE: This equipment has been tested and found to comply with the limits for a Class A digital device, pursuant to part 15 of the FCC Rules. These limits are designed to provide reasonable protection against harmful interference when the equipment is operated in a commercial environment. This equipment generates, uses, and can radiate radio frequency energy and, if not installed and used in accordance with the instruction manual, may cause harmful interference to radio communications. Operation of this equipment in a residential area is likely to cause harmful interference in which case the user will be required to correct the interference at his own expense.*

#### **FCC Interference Statement for Class B EVM devices**

*NOTE: This equipment has been tested and found to comply with the limits for a Class B digital device, pursuant to part 15 of the FCC Rules. These limits are designed to provide reasonable protection against harmful interference in a residential installation. This equipment generates, uses and can radiate radio frequency energy and, if not installed and used in accordance with the instructions, may cause harmful interference to radio communications. However, there is no guarantee that interference will not occur in a particular installation. If this equipment does cause harmful interference to radio or television reception, which can be determined by turning the equipment off and on, the user is encouraged to try to correct the interference by one or more of the following measures:*

- Reorient or relocate the receiving antenna.
- Increase the separation between the equipment and receiver.
- Connect the equipment into an outlet on a circuit different from that to which the receiver is connected.
- Consult the dealer or an experienced radio/TV technician for help.

#### 3.2 Canada

##### 3.2.1 For EVMs issued with an Industry Canada Certificate of Conformance to RSS-210 or RSS-247

#### **Concerning EVMs Including Radio Transmitters:**

This device complies with Industry Canada license-exempt RSSs. Operation is subject to the following two conditions:

(1) this device may not cause interference, and (2) this device must accept any interference, including interference that may cause undesired operation of the device.

#### **Concernant les EVMs avec appareils radio:**

Le présent appareil est conforme aux CNR d'Industrie Canada applicables aux appareils radio exempts de licence. L'exploitation est autorisée aux deux conditions suivantes: (1) l'appareil ne doit pas produire de brouillage, et (2) l'utilisateur de l'appareil doit accepter tout brouillage radioélectrique subi, même si le brouillage est susceptible d'en compromettre le fonctionnement.

#### **Concerning EVMs Including Detachable Antennas:**

Under Industry Canada regulations, this radio transmitter may only operate using an antenna of a type and maximum (or lesser) gain approved for the transmitter by Industry Canada. To reduce potential radio interference to other users, the antenna type and its gain should be so chosen that the equivalent isotropically radiated power (e.i.r.p.) is not more than that necessary for successful communication. This radio transmitter has been approved by Industry Canada to operate with the antenna types listed in the user guide with the maximum permissible gain and required antenna impedance for each antenna type indicated. Antenna types not included in this list, having a gain greater than the maximum gain indicated for that type, are strictly prohibited for use with this device.

### Concernant les EVMs avec antennes détachables

Conformément à la réglementation d'Industrie Canada, le présent émetteur radio peut fonctionner avec une antenne d'un type et d'un gain maximal (ou inférieur) approuvé pour l'émetteur par Industrie Canada. Dans le but de réduire les risques de brouillage radioélectrique à l'intention des autres utilisateurs, il faut choisir le type d'antenne et son gain de sorte que la puissance isotrope rayonnée équivalente (p.i.r.e.) ne dépasse pas l'intensité nécessaire à l'établissement d'une communication satisfaisante. Le présent émetteur radio a été approuvé par Industrie Canada pour fonctionner avec les types d'antenne énumérés dans le manuel d'usage et ayant un gain admissible maximal et l'impédance requise pour chaque type d'antenne. Les types d'antenne non inclus dans cette liste, ou dont le gain est supérieur au gain maximal indiqué, sont strictement interdits pour l'exploitation de l'émetteur.

#### 3.3 Japan

3.3.1 *Notice for EVMs delivered in Japan:* Please see [http://www.tij.co.jp/lstds/ti\\_ja/general/eStore/notice\\_01.page](http://www.tij.co.jp/lstds/ti_ja/general/eStore/notice_01.page) 日本国内に輸入される評価用キット、ボードについては、次のところをご覧ください。  
[http://www.tij.co.jp/lstds/ti\\_ja/general/eStore/notice\\_01.page](http://www.tij.co.jp/lstds/ti_ja/general/eStore/notice_01.page)

3.3.2 *Notice for Users of EVMs Considered "Radio Frequency Products" in Japan:* EVMs entering Japan may not be certified by TI as conforming to Technical Regulations of Radio Law of Japan.

If User uses EVMs in Japan, not certified to Technical Regulations of Radio Law of Japan, User is required to follow the instructions set forth by Radio Law of Japan, which includes, but is not limited to, the instructions below with respect to EVMs (which for the avoidance of doubt are stated strictly for convenience and should be verified by User):

1. Use EVMs in a shielded room or any other test facility as defined in the notification #173 issued by Ministry of Internal Affairs and Communications on March 28, 2006, based on Sub-section 1.1 of Article 6 of the Ministry's Rule for Enforcement of Radio Law of Japan,
2. Use EVMs only after User obtains the license of Test Radio Station as provided in Radio Law of Japan with respect to EVMs, or
3. Use of EVMs only after User obtains the Technical Regulations Conformity Certification as provided in Radio Law of Japan with respect to EVMs. Also, do not transfer EVMs, unless User gives the same notice above to the transferee. Please note that if User does not follow the instructions above, User will be subject to penalties of Radio Law of Japan.

【無線電波を送信する製品の開発キットをお使いになる際の注意事項】 開発キットの中には技術基準適合証明を受けていないものがあります。技術適合証明を受けていないものご使用に際しては、電波法遵守のため、以下のいずれかの措置を取っていただく必要がありますのでご注意ください。

1. 電波法施行規則第6条第1項第1号に基づく平成18年3月28日総務省告示第173号で定められた電波暗室等の試験設備でご使用いただく。
2. 実験局の免許を取得後ご使用いただく。
3. 技術基準適合証明を取得後ご使用いただく。

なお、本製品は、上記の「ご使用にあたっての注意」を譲渡先、移転先に通知しない限り、譲渡、移転できないものとします。

上記を遵守頂けない場合は、電波法の罰則が適用される可能性があることをご留意ください。日本テキサス・インスツルメンツ株式会社  
東京都新宿区西新宿 6 丁目 2 4 番 1 号  
西新宿三井ビル

3.3.3 *Notice for EVMs for Power Line Communication:* Please see [http://www.tij.co.jp/lstds/ti\\_ja/general/eStore/notice\\_02.page](http://www.tij.co.jp/lstds/ti_ja/general/eStore/notice_02.page)  
電力線搬送波通信についての開発キットをお使いになる際の注意事項については、次のところをご覧ください。[http://www.tij.co.jp/lstds/ti\\_ja/general/eStore/notice\\_02.page](http://www.tij.co.jp/lstds/ti_ja/general/eStore/notice_02.page)

#### 3.4 European Union

3.4.1 *For EVMs subject to EU Directive 2014/30/EU (Electromagnetic Compatibility Directive):*

This is a class A product intended for use in environments other than domestic environments that are connected to a low-voltage power-supply network that supplies buildings used for domestic purposes. In a domestic environment this product may cause radio interference in which case the user may be required to take adequate measures.

---

#### 4 *EVM Use Restrictions and Warnings:*

4.1 EVMS ARE NOT FOR USE IN FUNCTIONAL SAFETY AND/OR SAFETY CRITICAL EVALUATIONS, INCLUDING BUT NOT LIMITED TO EVALUATIONS OF LIFE SUPPORT APPLICATIONS.

4.2 User must read and apply the user guide and other available documentation provided by TI regarding the EVM prior to handling or using the EVM, including without limitation any warning or restriction notices. The notices contain important safety information related to, for example, temperatures and voltages.

#### 4.3 *Safety-Related Warnings and Restrictions:*

4.3.1 User shall operate the EVM within TI's recommended specifications and environmental considerations stated in the user guide, other available documentation provided by TI, and any other applicable requirements and employ reasonable and customary safeguards. Exceeding the specified performance ratings and specifications (including but not limited to input and output voltage, current, power, and environmental ranges) for the EVM may cause personal injury or death, or property damage. If there are questions concerning performance ratings and specifications, User should contact a TI field representative prior to connecting interface electronics including input power and intended loads. Any loads applied outside of the specified output range may also result in unintended and/or inaccurate operation and/or possible permanent damage to the EVM and/or interface electronics. Please consult the EVM user guide prior to connecting any load to the EVM output. If there is uncertainty as to the load specification, please contact a TI field representative. During normal operation, even with the inputs and outputs kept within the specified allowable ranges, some circuit components may have elevated case temperatures. These components include but are not limited to linear regulators, switching transistors, pass transistors, current sense resistors, and heat sinks, which can be identified using the information in the associated documentation. When working with the EVM, please be aware that the EVM may become very warm.

4.3.2 EVMs are intended solely for use by technically qualified, professional electronics experts who are familiar with the dangers and application risks associated with handling electrical mechanical components, systems, and subsystems. User assumes all responsibility and liability for proper and safe handling and use of the EVM by User or its employees, affiliates, contractors or designees. User assumes all responsibility and liability to ensure that any interfaces (electronic and/or mechanical) between the EVM and any human body are designed with suitable isolation and means to safely limit accessible leakage currents to minimize the risk of electrical shock hazard. User assumes all responsibility and liability for any improper or unsafe handling or use of the EVM by User or its employees, affiliates, contractors or designees.

4.4 User assumes all responsibility and liability to determine whether the EVM is subject to any applicable international, federal, state, or local laws and regulations related to User's handling and use of the EVM and, if applicable, User assumes all responsibility and liability for compliance in all respects with such laws and regulations. User assumes all responsibility and liability for proper disposal and recycling of the EVM consistent with all applicable international, federal, state, and local requirements.

5. *Accuracy of Information:* To the extent TI provides information on the availability and function of EVMs, TI attempts to be as accurate as possible. However, TI does not warrant the accuracy of EVM descriptions, EVM availability or other information on its websites as accurate, complete, reliable, current, or error-free.

#### 6. *Disclaimers:*

6.1 EXCEPT AS SET FORTH ABOVE, EVMS AND ANY MATERIALS PROVIDED WITH THE EVM (INCLUDING, BUT NOT LIMITED TO, REFERENCE DESIGNS AND THE DESIGN OF THE EVM ITSELF) ARE PROVIDED "AS IS" AND "WITH ALL FAULTS." TI DISCLAIMS ALL OTHER WARRANTIES, EXPRESS OR IMPLIED, REGARDING SUCH ITEMS, INCLUDING BUT NOT LIMITED TO ANY EPIDEMIC FAILURE WARRANTY OR IMPLIED WARRANTIES OF MERCHANTABILITY OR FITNESS FOR A PARTICULAR PURPOSE OR NON-INFRINGEMENT OF ANY THIRD PARTY PATENTS, COPYRIGHTS, TRADE SECRETS OR OTHER INTELLECTUAL PROPERTY RIGHTS.

6.2 EXCEPT FOR THE LIMITED RIGHT TO USE THE EVM SET FORTH HEREIN, NOTHING IN THESE TERMS SHALL BE CONSTRUED AS GRANTING OR CONFERRING ANY RIGHTS BY LICENSE, PATENT, OR ANY OTHER INDUSTRIAL OR INTELLECTUAL PROPERTY RIGHT OF TI, ITS SUPPLIERS/LICENSORS OR ANY OTHER THIRD PARTY, TO USE THE EVM IN ANY FINISHED END-USER OR READY-TO-USE FINAL PRODUCT, OR FOR ANY INVENTION, DISCOVERY OR IMPROVEMENT, REGARDLESS OF WHEN MADE, CONCEIVED OR ACQUIRED.

7. *USER'S INDEMNITY OBLIGATIONS AND REPRESENTATIONS.* USER WILL DEFEND, INDEMNIFY AND HOLD TI, ITS LICENSORS AND THEIR REPRESENTATIVES HARMLESS FROM AND AGAINST ANY AND ALL CLAIMS, DAMAGES, LOSSES, EXPENSES, COSTS AND LIABILITIES (COLLECTIVELY, "CLAIMS") ARISING OUT OF OR IN CONNECTION WITH ANY HANDLING OR USE OF THE EVM THAT IS NOT IN ACCORDANCE WITH THESE TERMS. THIS OBLIGATION SHALL APPLY WHETHER CLAIMS ARISE UNDER STATUTE, REGULATION, OR THE LAW OF TORT, CONTRACT OR ANY OTHER LEGAL THEORY, AND EVEN IF THE EVM FAILS TO PERFORM AS DESCRIBED OR EXPECTED.

8. *Limitations on Damages and Liability:*

8.1 *General Limitations.* IN NO EVENT SHALL TI BE LIABLE FOR ANY SPECIAL, COLLATERAL, INDIRECT, PUNITIVE, INCIDENTAL, CONSEQUENTIAL, OR EXEMPLARY DAMAGES IN CONNECTION WITH OR ARISING OUT OF THESE TERMS OR THE USE OF THE EVMS , REGARDLESS OF WHETHER TI HAS BEEN ADVISED OF THE POSSIBILITY OF SUCH DAMAGES. EXCLUDED DAMAGES INCLUDE, BUT ARE NOT LIMITED TO, COST OF REMOVAL OR REINSTALLATION, ANCILLARY COSTS TO THE PROCUREMENT OF SUBSTITUTE GOODS OR SERVICES, RETESTING, OUTSIDE COMPUTER TIME, LABOR COSTS, LOSS OF GOODWILL, LOSS OF PROFITS, LOSS OF SAVINGS, LOSS OF USE, LOSS OF DATA, OR BUSINESS INTERRUPTION. NO CLAIM, SUIT OR ACTION SHALL BE BROUGHT AGAINST TI MORE THAN TWELVE (12) MONTHS AFTER THE EVENT THAT GAVE RISE TO THE CAUSE OF ACTION HAS OCCURRED.

8.2 *Specific Limitations.* IN NO EVENT SHALL TI'S AGGREGATE LIABILITY FROM ANY USE OF AN EVM PROVIDED HEREUNDER, INCLUDING FROM ANY WARRANTY, INDEMNITY OR OTHER OBLIGATION ARISING OUT OF OR IN CONNECTION WITH THESE TERMS, , EXCEED THE TOTAL AMOUNT PAID TO TI BY USER FOR THE PARTICULAR EVM(S) AT ISSUE DURING THE PRIOR TWELVE (12) MONTHS WITH RESPECT TO WHICH LOSSES OR DAMAGES ARE CLAIMED. THE EXISTENCE OF MORE THAN ONE CLAIM SHALL NOT ENLARGE OR EXTEND THIS LIMIT.

9. *Return Policy.* Except as otherwise provided, TI does not offer any refunds, returns, or exchanges. Furthermore, no return of EVM(s) will be accepted if the package has been opened and no return of the EVM(s) will be accepted if they are damaged or otherwise not in a resalable condition. If User feels it has been incorrectly charged for the EVM(s) it ordered or that delivery violates the applicable order, User should contact TI. All refunds will be made in full within thirty (30) working days from the return of the components(s), excluding any postage or packaging costs.

10. *Governing Law:* These terms and conditions shall be governed by and interpreted in accordance with the laws of the State of Texas, without reference to conflict-of-laws principles. User agrees that non-exclusive jurisdiction for any dispute arising out of or relating to these terms and conditions lies within courts located in the State of Texas and consents to venue in Dallas County, Texas. Notwithstanding the foregoing, any judgment may be enforced in any United States or foreign court, and TI may seek injunctive relief in any United States or foreign court.

Mailing Address: Texas Instruments, Post Office Box 655303, Dallas, Texas 75265  
Copyright © 2019, Texas Instruments Incorporated



## IMPORTANT NOTICE AND DISCLAIMER

TI PROVIDES TECHNICAL AND RELIABILITY DATA (INCLUDING DATASHEETS), DESIGN RESOURCES (INCLUDING REFERENCE DESIGNS), APPLICATION OR OTHER DESIGN ADVICE, WEB TOOLS, SAFETY INFORMATION, AND OTHER RESOURCES "AS IS" AND WITH ALL FAULTS, AND DISCLAIMS ALL WARRANTIES, EXPRESS AND IMPLIED, INCLUDING WITHOUT LIMITATION ANY IMPLIED WARRANTIES OF MERCHANTABILITY, FITNESS FOR A PARTICULAR PURPOSE OR NON-INFRINGEMENT OF THIRD PARTY INTELLECTUAL PROPERTY RIGHTS.

These resources are intended for skilled developers designing with TI products. You are solely responsible for (1) selecting the appropriate TI products for your application, (2) designing, validating and testing your application, and (3) ensuring your application meets applicable standards, and any other safety, security, or other requirements. These resources are subject to change without notice. TI grants you permission to use these resources only for development of an application that uses the TI products described in the resource. Other reproduction and display of these resources is prohibited. No license is granted to any other TI intellectual property right or to any third party intellectual property right. TI disclaims responsibility for, and you will fully indemnify TI and its representatives against, any claims, damages, costs, losses, and liabilities arising out of your use of these resources.

TI's products are provided subject to TI's Terms of Sale ([www.ti.com/legal/termsofsale.html](http://www.ti.com/legal/termsofsale.html)) or other applicable terms available either on [ti.com](http://ti.com) or provided in conjunction with such TI products. TI's provision of these resources does not expand or otherwise alter TI's applicable warranties or warranty disclaimers for TI products.

Mailing Address: Texas Instruments, Post Office Box 655303, Dallas, Texas 75265  
Copyright © 2019, Texas Instruments Incorporated