

Description

The Si21662D integrates two separate high-performance digital demodulators for the DVB-S2/S and DVB-S2X standards into a single compact package. Leveraging Silicon Labs' proven digital demodulation architecture, the Si21662D achieves excellent reception performance while significantly minimizing front-end design complexity, cost, and power dissipation. Connecting the Si21662D to a dual satellite tuner, results in a high-performance and cost optimized TV or STB front-end solution.

The satellite reception allows demodulating widespread DVB-S, DIRECTV™ (DSS), DVB-S2, DIRECTV™ (AMC) legacy standards, and new Part II of DVB-S2 (S2X) satellite broadcast standard. A zero-IF interface (differential) allows for a seamless connection to market proven satellite silicon tuners. It also integrates two DiSEqC™ 2.0 LNB interfaces for satellite dish control and, for each satellite demodulator, an equalizer to compensate for echoes in long cable feeds from the LNB to the satellite tuner RF input.

Variable Coding and Modulation (VCM), QPSK/8PSK, 8/16/32APSK demodulation schemes and broadcast services profile are the main specifications of the DVB-S2/S2X demodulator. Silicon Labs' innovative LDPC and BCH decoding architecture delivers best-in-class reception while exhibiting low power dissipation.

The Si21662D offers an on-chip blind scanning algorithm, as well as blind lock function.

The Si21662D embeds two independent programmable transport stream interfaces which provide a flexible range of output modes, including a cross-bar functionality, and are fully compatible with all MPEG decoders or conditional access modules to support any customer application.

Features

- Pin-to-pin compatible with all dual demodulator family: Si216x2 and Si218x2
- API compatible with all single and all dual demodulators
- DVB-S2 (ETSI EN 302 307-1 V1.4.1)
 - QPSK/8PSK demodulator
- DVB-S2X (ETSI EN302 307-2 V1.1.1)
 - Broadcast profile supported
 - QPSK/8PSK, 8/16/32APSK demodulator
 - Roll-off factors from 0.05 to 0.35
 - VCM supported
 - ISSY and NPD supported
 - MIS supported
 - Output modes: TS, GPCS, and GSE-HEM supported
 - Channel bonding for TS transmission supported
- DVB-S (ETSI EN 300 421) and DSS supported
 - QPSK demodulator and enhanced FEC decoder
- Dual DiSEqC™ 2.x interface, Unicable support
- 1 to 45 MSps for all satellite standards (<40 MSps in 32APSK)
- I²C serial bus interfaces (master and host)
- Upgradeable with firmware patch download via fast SPI or I²C (broadcast mode supported)
- Dual independent differential ZIF I/Q inputs
- GPIOs and multi-purpose ports (two per demodulator)
- Separate flexible TS interfaces with serial or parallel outputs and cross-bar feature
- Fast lock times
- Only two power supplies: 1.2 and 3.3 V
- 8x8 mm, QFN-68 pin package, Pb-free/RoHS compliant

Applications

- Multi-receiver iDTV: on-board or in a NIM
- Advanced multimedia PVR STBs
- PC-TV accessories
- PVR, DVD, and Blu-Ray disc recorders

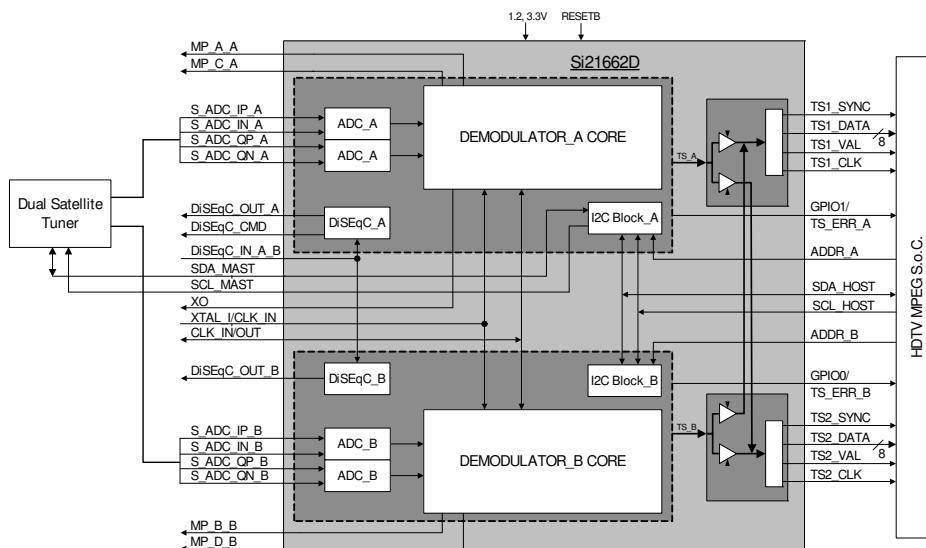

Selected Electrical Specifications

(T_A = -10 to 70 °C).

Parameter	Test Condition	Min	Typ	Max	Unit
General					
Input clock reference		4	—	30	MHz
Supported XTAL frequency		16	—	30	MHz
Total power consumption for each demodulator	DVB-S2 ¹	—	421	—	mW
	DVB-S ²	—	230	—	mW
Thermal resistance (θ _{JA})	4 layer PCB	—	42	—	°C/W
Power Supplies					
V _{DD_VCORE}		1.14	1.20	1.30	V
V _{DD_VANA}		3.00	3.30	3.60	V
V _{DD_VIO}		3.00	3.30	3.60	V
Notes:					
1. Test conditions: 32 Mbaud, CR = 3/5, 8PSK, pilots On, parallel TS, C/N at picture failure.					
2. Test conditions: 30 Mbaud, CR = 7/8, parallel TS, at QEF: BER = 2 x 10 ⁻⁴ .					

Pin Assignments

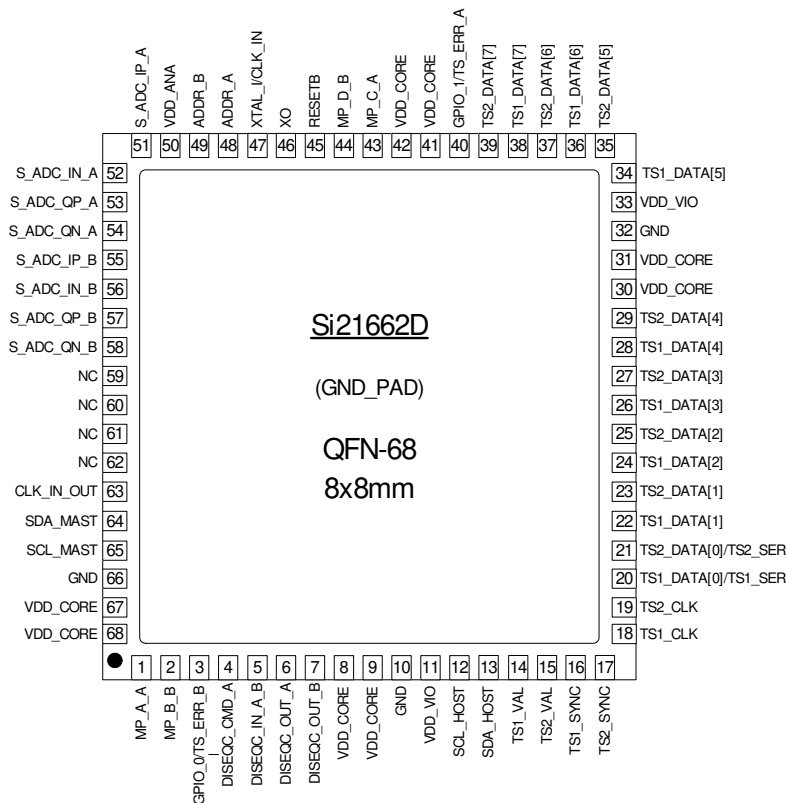

Selection Guide

Part #	Description
Si21662-D60-GM/R	Dual Digital TV Demodulator for DVB-S/S2/S2X, 8x8 mm QFN-68