

C6200 Generator Controller

- Combined Synchronizer and Loadsharer
- Synchroscope on the front panel
- Reverse power protection
- Excitation loss protection
- 8 programmable inputs and outputs for auxiliary functions
- RS485 Modbus communication
- CAN bus for optional user interface
- Direct control of electronic governors
- Increase/ decrease pulse outputs for speed and voltage control

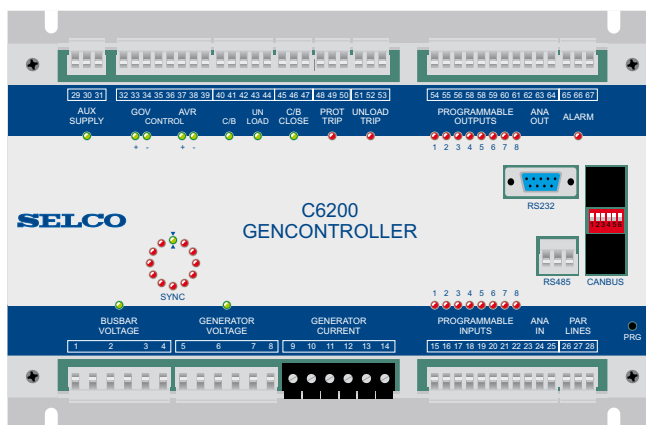

Figure 1. Front of C6200

Application

C6200 is a combined synchronizer and loadsharer for paralleling of generators. The unit can be used in any application where generator should run in parallel with each other or with the grid. For easy commissioning the unit includes a synchroscope on the front panel.

C6200 also includes reverse power and excitation loss protection of the generator.

8 sets of programmable auxiliary inputs and outputs are available. They can be used for auxiliary functions like external commands for start synchronizing or load ramp functions.

RS485 Modbus communication allows read out of the status of the unit or external control of the unit e.g. by a PLC. An analogue output can be used for indication of actual measurement values such as load or frequency of the generator.

A User Interface Unit S6500 can be connected through CAN bus. Easy accessible modular connectors are furnished on the front side of the unit.

Speed Control

For synchronizing and active load sharing (kW) C6200 offers two sets of outputs for speed control:

In case the engine is equipped with an electronic governor, the analogue outputs can be used for control of the speed. The output signal can be a voltage, current or PWM signal.

It is possible to program the output signals regarding level and reference, so they can be adapted to virtually any governor in the market such as GAC or Woodward.

In case it alternatively is desired to control the speed through a motorized potentiometer or the servomotor of a conventional governor a set of open collector outputs can be used.

Voltage Control

For voltage matching and reactive load sharing (kVAr) C6200 offers two sets of outputs for voltage control: The Automatic Voltage Regulator (AVR) of the alternator can be controlled by an analogue signal (voltage, current or PWM signal).

It is possible to program the output signals regarding level and reference, so they can be adapted to virtually any AVR on the market.

In case a motorized potentiometer shall be used for control of the AVR a set of open collector outputs can be used. The open collector outputs will then control

relays which will control the motorized potentiometer.

Synchronizing

In case increase/ decrease pulse contacts are used for speed control, synchronizing is performed according to the dynamic synchronizing principle. This means that the incoming generator will be connected with a slightly higher frequency than the busbar frequency.

The purpose of this function is to make sure that the incoming generator will be loaded immediately in order not to take reverse power.

If alternatively the analogue outputs are used, synchronizing is done according to the static synchronizing principle. Frequency and phase angle will then be adjusted so the parameters of the incoming generator match the parameters of the busbar (frequency of the incoming generator = frequency of the busbar). This is possible as the regulation is much faster when using the analogue outputs. The loadsharer will load the generator immediately after connection thus avoiding a reverse power situation.

Voltage Matching

During synchronizing C6200 will adjust the voltage of the generator according to the busbar voltage.

Load Sharing (kW)

The load sharing function will make sure that the active load in an installation will be proportionally distributed between the parallel running generators. The load will be shared according to the percentage of nominal power of the generators. It is possible to adjust a load deviation in case a generator should be loaded at a different rate than the other generators.

Reactive Load Sharing (kVAr)

The reactive load sharing function will make sure that the reactive load in an installation will be proportionally distributed between the parallel running generators. The reactive load will be shared according to the percentage of nominal reactive power of the generators. Also here it is possible to adjust a load deviation.

Reverse Power Protection

C6200 includes a reverse power protection function with fixed time characteristics.

It is possible to define a trip level in % of the nominal power and a trip delay in seconds [s].

The unit includes two trip relays, one for protection trips and another for operational (unload) trips. The reverse power protection function trips the protection trip relay.

Excitation Loss Protection

In case generators are running in parallel their output voltages are the same. If one of the generators loses its excitation, it will take a reverse inductive current. As this phenomenon will load the other generator with reactive load, it can lead to a decreasing busbar voltage. Eventually this could cause a low voltage trip on all connected generators resulting in a blackout.

To avoid this, C6200 can measure the level and direction of the reactive current. If the reactive current is leading into reverse direction and is larger than a certain level, the C/B of the faulty

generator will be tripped. As the healthy generators will keep supplying the busbar, this function can avoid blackouts.

The excitation loss protection is defined by a trip level in % of the nominal reactive power in reverse direction and a trip delay in seconds [s]. It will trip the protection trip output relay.

Programmable Auxiliary I/O

C6200 includes 8 programmable inputs and 8 programmable outputs that can be used for functions such as indication of protection trips, external commands for start of synchronizing or load sharing and manual control of speed and voltage.

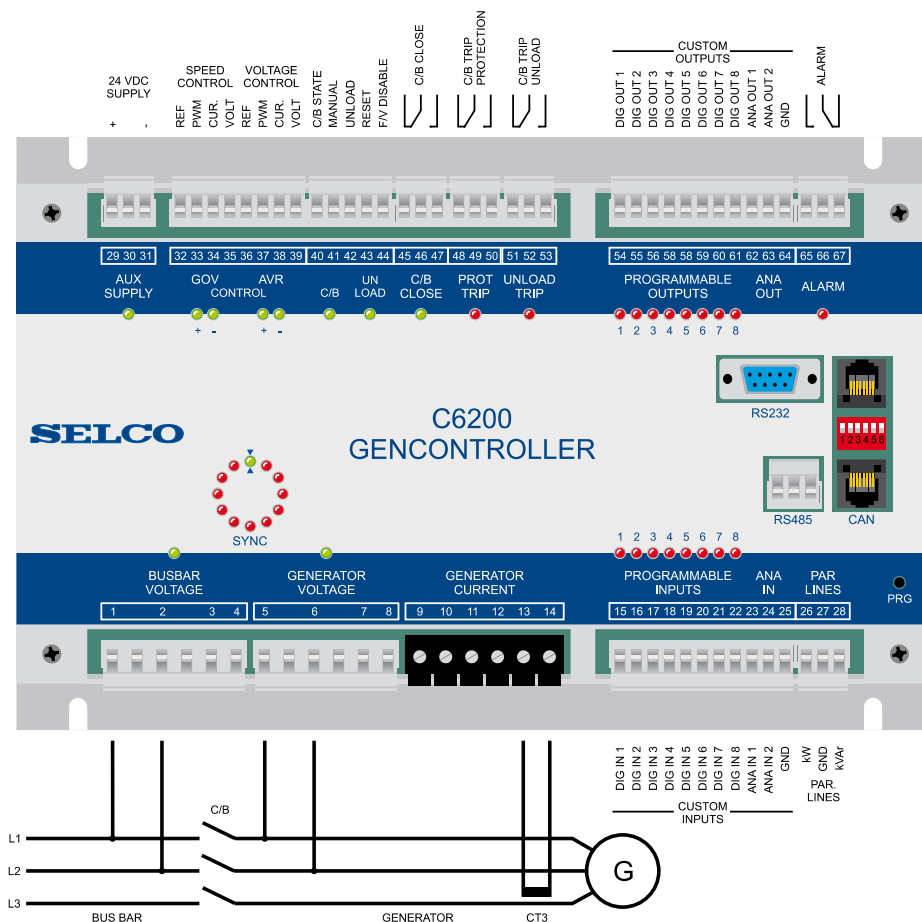

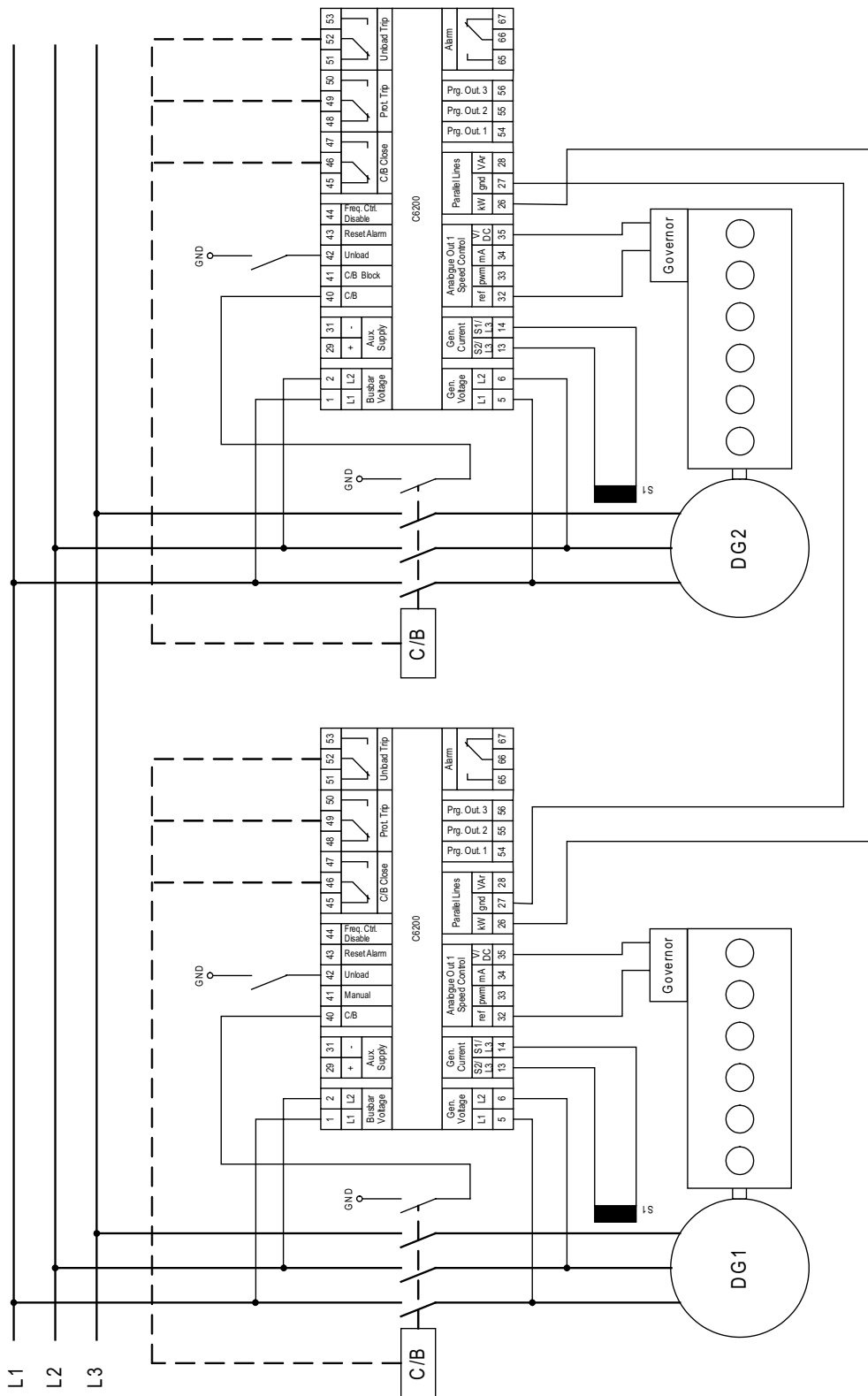

Figure 3. Simple 2 generator application

Specifications

C6200 Engine Controller

Voltage	24 VDC (-30% / +20%)
Generator voltage	63V to 690V
Generator rated frequency	50Hz/ 60Hz
Generator max. current	30.000A
Current transformer secondary current	5A
Power consumption	Max 200mA
Ambient temp. range	-20° C / +70° C
Relay contacts	230VAC / 2A & 30VDC / 2A
Open collector outputs	200mA per channel
External communication	MODBUS RTU
Programmable digital inputs	8
Programmable digital outputs	8
Programmable analogue outputs	2
Current measurement	Single phase
Weight	1,500 Kg
Dimension (mm)	(282 x 182 x 50)mm

Type Selection

Type	Supply voltage	Generator voltage	Current transformer
C6200.0010	24VDC	63V – 690V	5A
C6200.0020	24VDC	63V – 690V	1A

SELCO Worldwide



- SELCO Denmark
- SELCO subsidiary
- SELCO representation

Main office:
 SELCO A/S
 Betonvej 10
 DK-4000 Roskilde
 Denmark
 Phone: + 45 7026 1122
 Fax: + 45 7026 2522
 e-mail: selco.dk@selco.com
 www.selco.com

