

PART NUMBER	REVISION	DESCRIPTION	FEED TYPE
2151417-1	B	FINE CRIMP HEIGHT ADJUST	MECHANICAL
2151417-2	B	FINE CRIMP HEIGHT ADJUST	PNEUMATIC
5-2151417-1	B	SEAL STRIPPER CRIMPER TERMINATING UNIT	MECHANICAL
5-2151417-2	B	SEAL STRIPPER CRIMPER TERMINATING UNIT	PNEUMATIC
7-2151417-1	B	MECHANICAL AND CRIMP TOOLING KIT	MECHANICAL
7-2151417-2	B	PNEUMATIC AND CRIMP TOOLING KIT	PNEUMATIC
7-2151417-7	A	CRIMP TOOLING KIT	-

ATLANTIC VERSION TERMINATOR INTERFACE ADAPTER

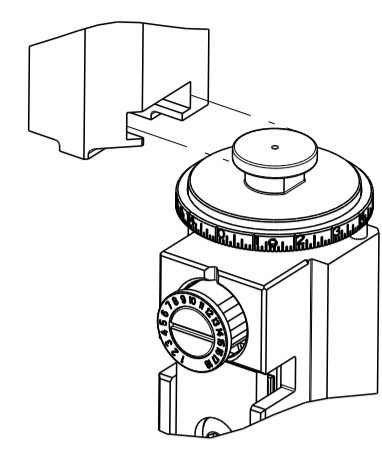

APPLICATOR DATA		
CRIMP	SIZE	TYPE
WIRE	2.00 mm [.079]	F
INSUL	3.94 mm [.155]	O

APPLICATOR INSTRUCTIONS
408-35042

TERMINAL DATA: LEAR TERMINAL		LEAR CRIMP SPECIFICATION	
TERMINAL NAME: TERMINAL			
WIRE STRIP LENGTH		INSULATION DIAMETER RANGE	
4.20-4.80 mm [.165-.189 IN]		Ø1.20-2.10 mm [.047-.083 IN]	
TERMINAL APPLICATION SPECIFICATION	26806 Rev 1		
TERMINALS APPLIED			
TE TERMINAL	GWH/LEAR TERMINAL	TE SEAL	GWH/LEAR SEAL
1949751-1	26806.201.184	1572316-1	16695.627.642
1949751-2	7815102	1949110-1	14448.627.621
		SEAL INSULATION DIAMETER RANGE	Ø1.70 - 2.10

WIRE SIZE	CRIMP HEIGHT mm [INCH]	CRIMP HEIGHT REFERENCE SETTING
1.00mm2	1.25+/-0.05 [.049+/- .002]	5.5
0.75mm2	1.20+/-0.05 [.047+/- .002]	6.0
0.50mm2	1.15+/-0.05 [.045+/- .002]	6.5

- 1 RECOMMENDED SPARE PARTS
- 2 REFER TO SUPPLIED INSTRUCTION SHEET FOR CLEANING, LUBRICATION AND STORAGE OF APPLICATOR.
- 3 APPLY PART NUMBER 1-23419-5 LOCTITE TO THREADS OF ITEM 180. APPLY PART NUMBER 2-23419-6 LOCTITE TO THREADS OF ITEM 242.
- 4 CRIMP HEIGHT REFERENCE SETTING WAS THE SETTING USED WHEN THE APPLICATOR WAS QUALIFIED AT THE FACTORY. ADJUSTMENT MAY BE NECESSARY WHEN RUNNING APPLICATOR IN THE FIELD.
- 5. UNLESS SPECIFIED OTHERWISE TORQUE VALUES SHALL BE USED PER DOCUMENT, 101-35000.
- 6 APPLY TORQ-SEAL IN ALLEN SOCKET TO FILL HOLE AFTER FLAT HD HAS BEEN ADJUSTED TO CORRECT HEIGHT AT QUALIFICATION. APPLY #1-23419-5 LOC-TITE TO THREADS.

***WARNING**
 ON INSTALLATION, SET WIRE DISC TO CRIMP HEIGHT REFERENCE SETTING FOR LARGEST WIRE SIZE. CRIMP HEIGHT REFERENCE SETTINGS GREATER THAN THE VALUE SHOWN MAY CAUSE DAMAGE TO THE CRIMP TOOLING, REFER TO THE INSTRUCTION SHEET FOR PROPER SETUP AND ADJUSTMENTS.

ATLANTIC VERSION
 Shown on sheets 1 of 4 & 2 of 4
 (Pacific version shown on sheets 3 of 4 & 4 of 4)

LOC	DIST	REVISIONS					
A	66	P	LTN	DESCRIPTION	DATE	OWN	APVD
		A		RELEASED	03MARCH2015	KS	GB
		B		ECR-21-004118	07APR2021	LG	TE

-	-	-	1	1	-	-	1803515-3	RAM ASSEMBLY, SF ATLANTIC	293
-	-	-	1	1	-	-	2-1803583-1	APPLICATOR BASIC ASSEMBLY, SF	292
-	1	-	1	-	1	-	2119641-1	FEED CAM, AIR FEED	248
-	1	1	1	1	1	1	2119082-3	CAM, SNAIL, INSULATION ADJUSTMENT	244
-	1	1	1	1	1	1	2079764-1	WASHER, WAVE SPRING, CREST-TO-CREST	243
-	1	1	1	1	1	1	2119083-1	RETAINER, INSULATION DIAL	242
-	1	1	1	1	1	1	7-18023-7	SCR, SKT HD CAP M3 X 4.0	241
-	-	1	-	1	-	1	2119580-1	MECHANICAL FEED ASSEMBLY	239
-	1	-	1	-	1	-	2844940-1	AIR FEED MODULE	238
-	-	-	1	1	-	-	4-1722335-3	STRIPPER, SIDE FEED	182
-	-	-	1	1	-	-	1-5018030-0	NUT, HEX, REG, RoHS, M3.5	181
-	-	-	1	1	-	-	1-1752354-9	STANDOFF,HOLD-DOWN	180
-	-	-	1	1	-	-	993111-1	PIN, SLOTTED SPRING 3.0 X 20.0	177
-	-	-	1	1	-	-	5-22280-0	SPRING, COMPRESSION	176
-	-	-	1	1	-	-	1752353-3	GUIDE PIN,HOLDDOWN	175
-	-	-	1	1	-	-	1901680-2	GUIDE PIN,HOLDDOWN	174
-	REF	REF	REF	REF	REF	REF	994970-2	COUNTER, MAGNETIC	164
-	1	1	1	1	1	1	2844908-1	SCREW, LOCKING	99
-	1	1	1	1	1	1	2844907-1	POST, LOCKING	98
-	2	2	2	2	2	2	2168083-1	SCR, SKT HD CAP, RoHS, M3 X 8.0	97
-	1	1	1	1	1	1	1-690438-0	FRONT STRIP GUIDE	96
-	1	1	1	1	1	1	455888-5	SPACER, CRIMPER	82
-	1	1	1	1	1	1	1803607-3	DOCUMENTATION PACKAGE	71
-	1	1	1	1	1	1	2119740-1	TAG,IDENTIFICATION	67
-	2	2	2	2	2	2	2168078-1	SCREW, DRIVE, RH, RoHS, 2 x .188	66
-	2	2	2	2	2	2	22281-8	SPRING, COMPRESSION	61
-	1	1	1	1	1	1	2168083-2	SCR, SKT HD CAP, RoHS, M4 X 8.0	60
-	1	1	1	1	1	1	5-18022-5	SCR, HEX HD CAP, M4 X 6.0	59
-	1	1	1	1	1	1	985575-3	SCR, FLT SKT HD CAP M3 X 10.0	57
-	1	1	1	1	1	1	1338685-1	PAWL, FEED	56
-	4	4	4	4	4	4	2168083-3	SCR, SKT HD CAP, RoHS, M4 X 12.0	54
-	2	2	2	2	2	2	1-2168083-0	SCR, SKT HD CAP, RoHS, M4 X 10	53
-	1	1	1	1	1	1	5018030-1	NUT, HEX, REG, RoHS, M3	52
-	1	1	1	1	1	1	811242-5	BUMPER, HOLD DOWN	51
-	1	1	1	1	1	1	690753-2	SPACER, TONKER	50
-	1	2	1	2	1	2	18023-9	SCR, SKT HD CAP M4 X 6.0	49
-	-	1	-	1	-	1	2119652-1	FEED CAM, PRE FEED	48
-	-	1	-	1	-	1	2119653-1	FEED CAM, POST FEED	47
-	1	1	-	-	1	1	1803583-9	APPLICATOR BASIC ASSEMBLY, SF	46
-	1	1	-	-	1	1	1803515-1	RAM ASSEMBLY, SF ATLANTIC	44
-	1	1	1	1	1	1	1803602-1	SCR, BHSC, RoHS (M8 X 25)	41
-	1	1	1	1	1	1	2-1752356-0	SUPPORT, TERMINAL	34
-	2	2	2	2	2	2	2079383-5	SCR, BHSC, RoHS (M4 X 20)	33
-	2	2	2	2	2	2	3-2844962-0	SPACER, CYLINDRICAL, STRIP GUIDE	30
-	1	1	1	1	1	1	2844992-3	ASSEMBLY, STRIP GUIDE	29
-	1	1	1	1	1	1	455888-3	SPACER, CRIMPER	28
-	2	2	2	2	2	2	2-18032-5	SCR, SET, FLT PNT, M5 X 20.0	27
-	1	1	1	1	1	1	356835-1	LEVER, DRAG RELEASE	26
-	1	1	1	1	1	1	240792-1	DRAG, TERMINAL	25
-	1	1	1	1	1	1	1320928-2	STRIP GUIDE	24
-	1	1	1	1	1	1	980371-4	SCR, SKT HD SHLDR 5.0 DIA X 6.0	23
-	1	1	-	-	1	1	2168083-2	SCR, SKT HD CAP, RoHS, M4 X 8.0	21
-	2	2	1	1	2	2	1-18028-2	WASHER, FLAT, REG M4	20
-	1	1	-	-	1	1	2119533-1	STRIPPER, SIDE FEED	19
-	1	1	1	1	1	1	2119806-1	INSERT, SHEAR	13
-	1	1	1	1	1	1	3-22280-3	SPRING, COMPRESSION	12
-	1	1	1	1	1	1	1-356885-4	STOP, SHEAR	11
-	1	1	1	1	1	1	2119805-1	SHEAR HOLDER, FRONT	10
-	1	1	1	1	1	1	318707-1	FLOATING SHEAR, FRONT	9
1	2	2	1	1	1	1	6-1633138-5	ANVIL, COMBINATION	8
-	1	1	1	1	1	1	3-240641-8	SPACER	7
-	-	-	-	-	-	-	-	-	6
-	1	1	1	1	1	1	2119781-1	DEPRESSOR, SHEAR	5
-	1	1	1	1	1	1	238011-4	BLOCK, CRIMPER SPACER	4
1	2	2	1	1	1	1	2-2119784-9	CRIMPER, INSULATION O PREMIUM	3
-	1	1	1	1	1	1	1-455888-3	SPACER, CRIMPER	2
1	2	2	1	1	1	1	2-1633738-8	CRIMPER, WIRE	1

DIMENSIONS:		TOLERANCES UNLESS OTHERWISE SPECIFIED:		OWN	CHK	DATE
mm	0 PLC ±	1 PLC ±	2 PLC ±	STAKEM	G. BAILEY	12FEB2015
	3 PLC ±	4 PLC ±	ANGLES ±	APVD	T. ELBIN	12FEB2015
MATERIAL	FINISH	WEIGHT	SCALE	Customer Accessible Production Drawing		

LOC	DIST	REVISIONS					
		P	LYN	DESCRIPTION	DATE	OWN	APVD
A	66	-	-	SEE SHEET 1	-	-	-

FEED TYPE MECHANICAL

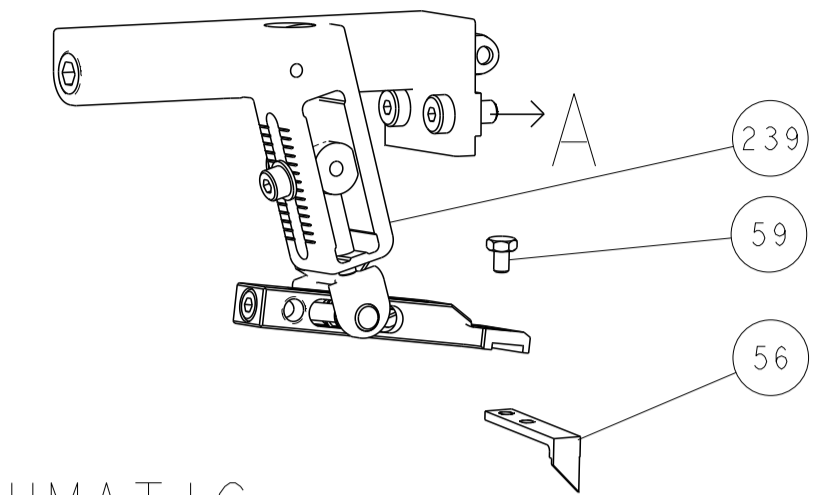

PNEUMATIC

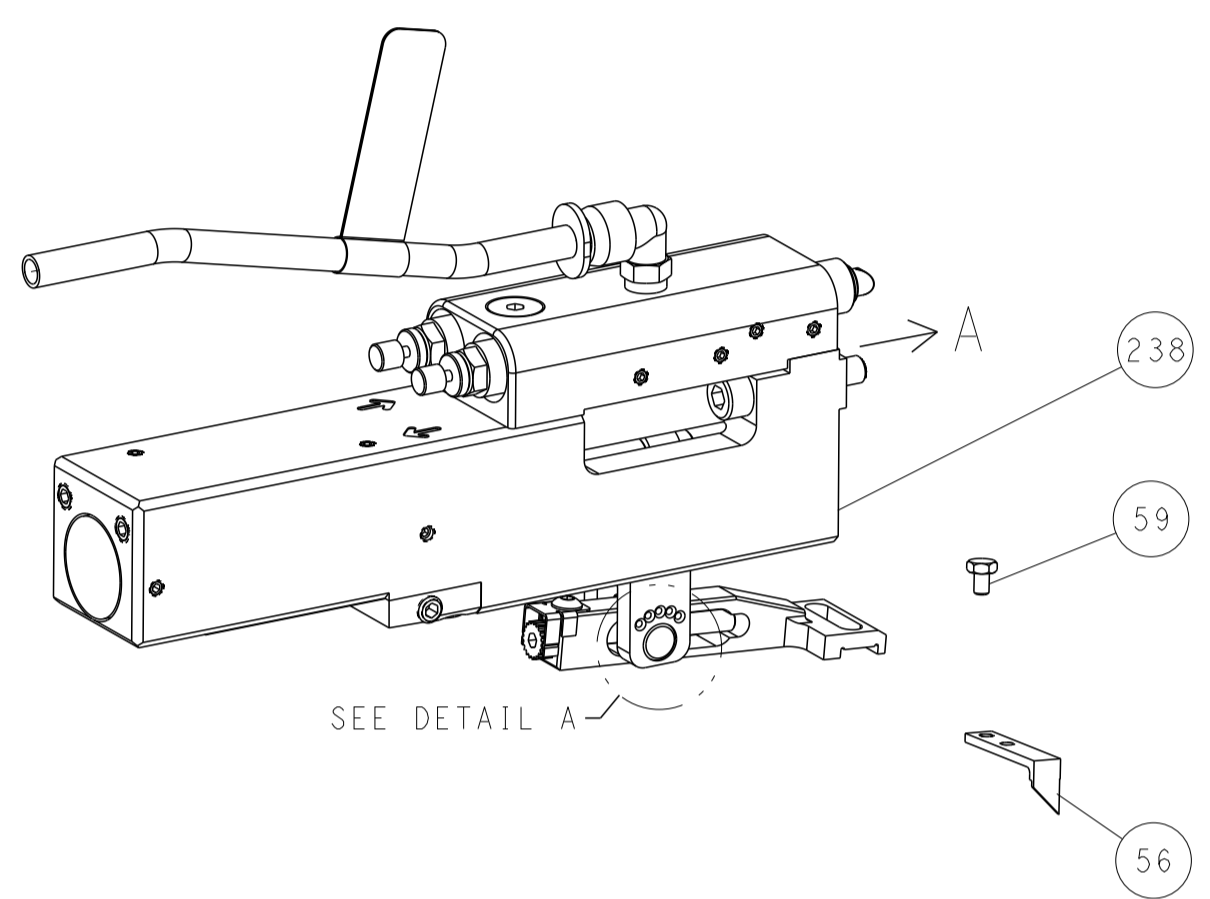

FEED SPRING SETTING POSITION (SHOWN FROM REAR SIDE)

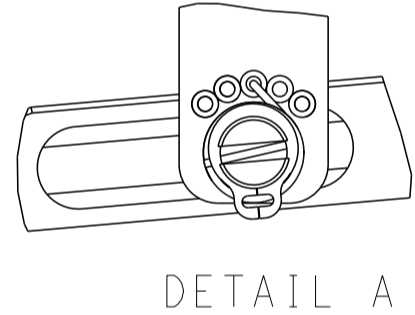

DETAIL A

CAM POSITIONS

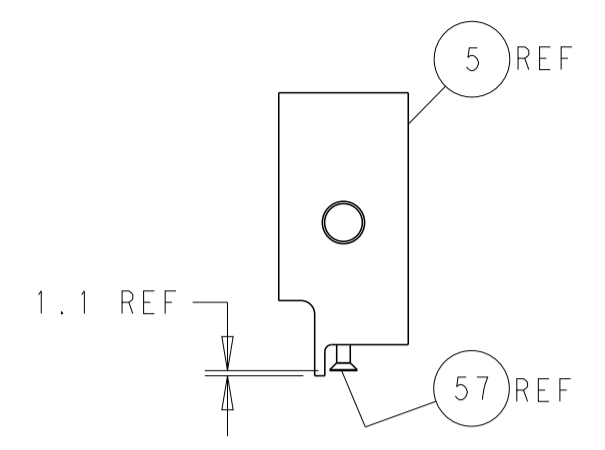
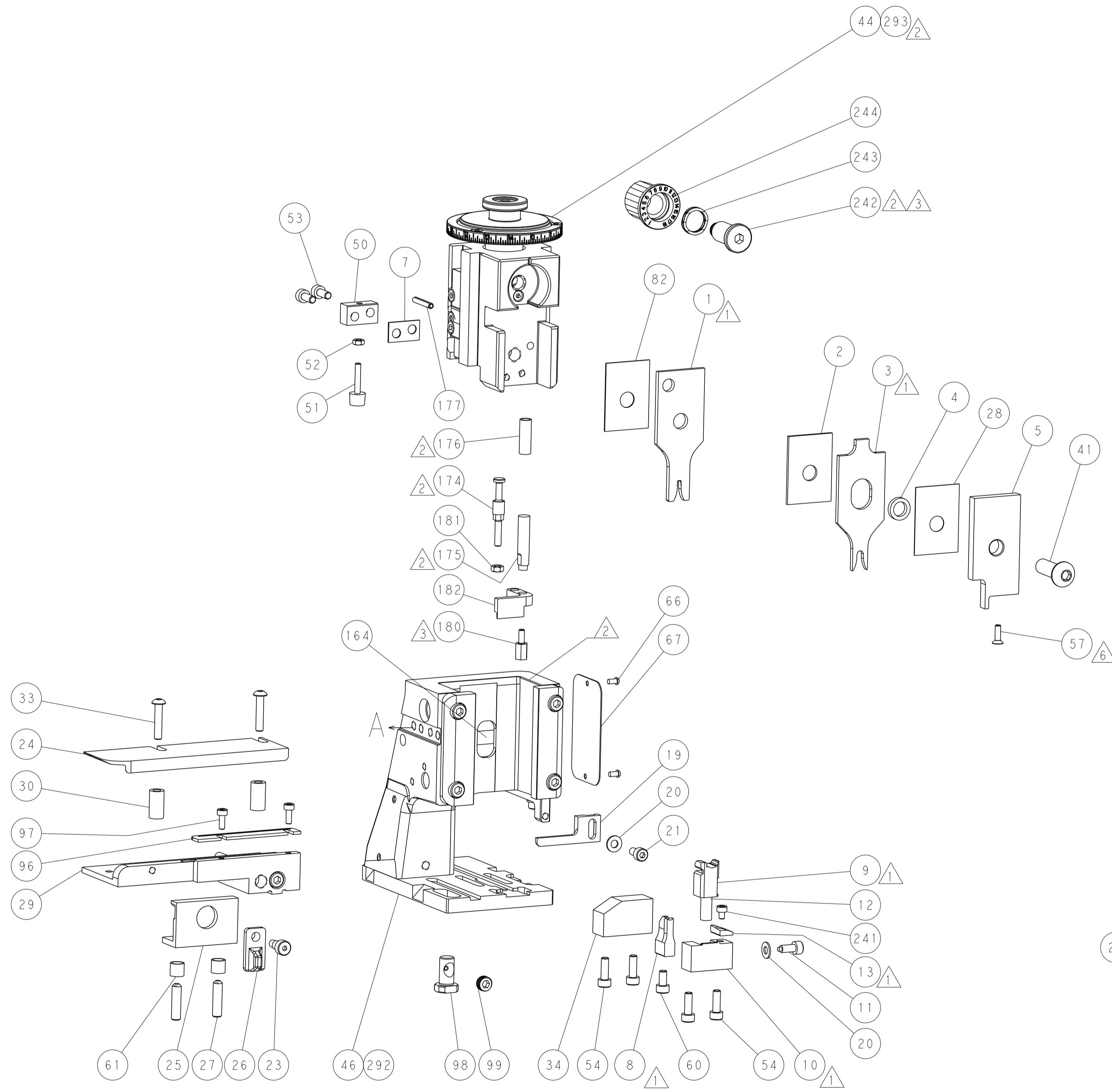
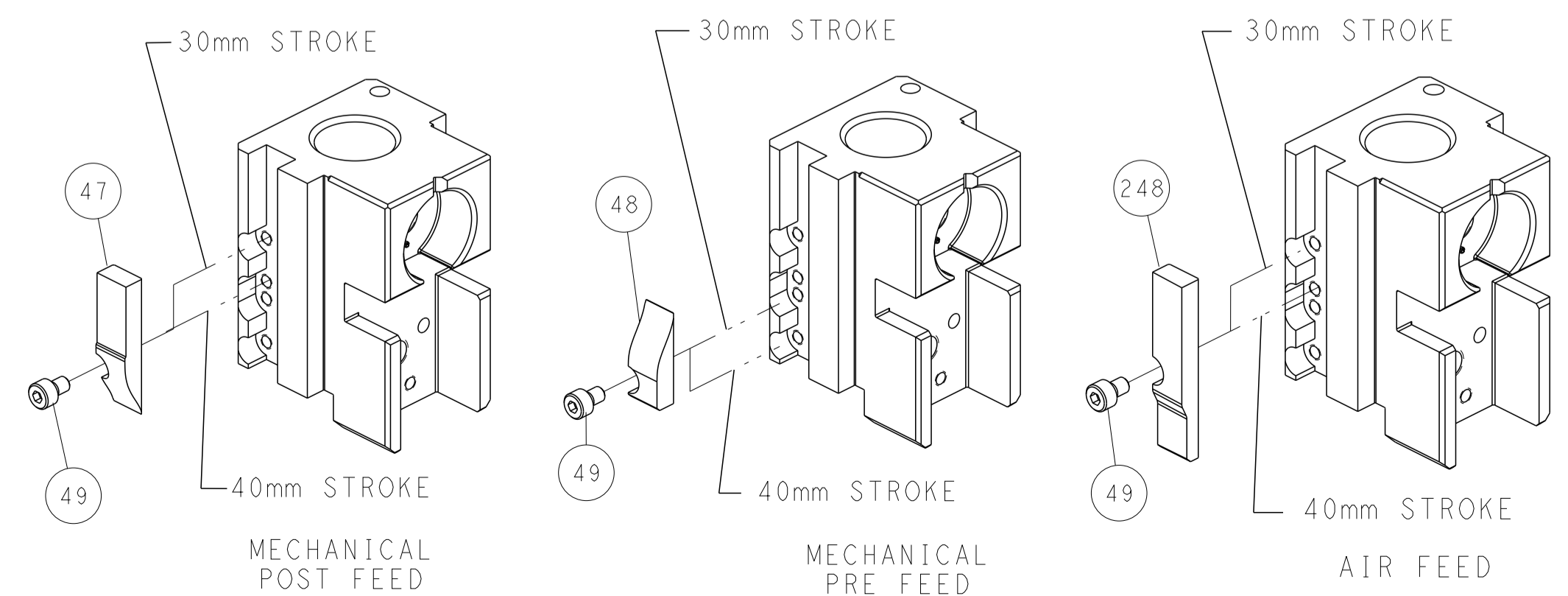

SHEAR DEPRESSOR DETAIL

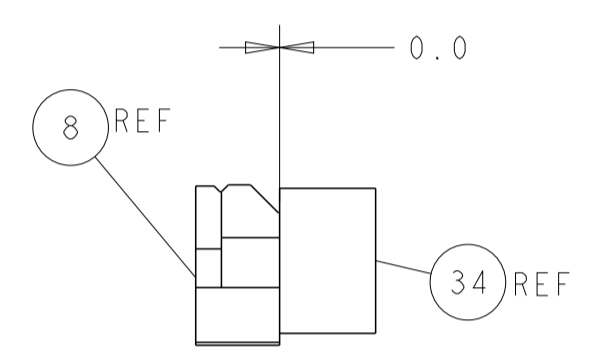

TERMINAL SUPPORT LOCATION

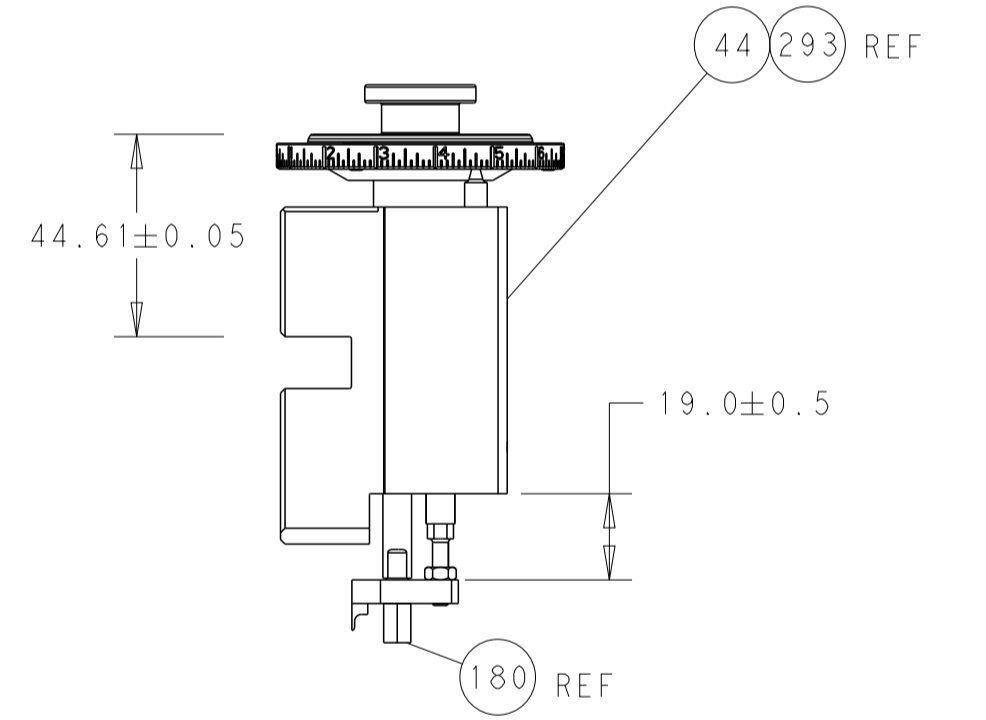

RAM AND HOLD DOWN SET-UP

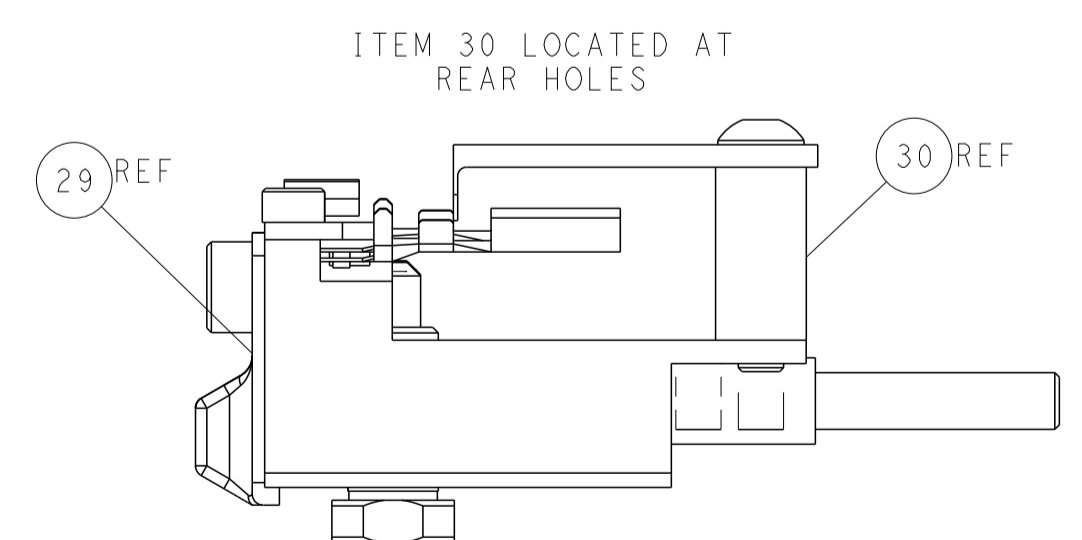

FEED TRACK POSITION GUIDE BY WIRE BARREL

ATLANTIC VERSION
 Shown on sheets 1 of 4 & 2 of 4
 (Pacific version shown on sheets 3 of 4 & 4 of 4)

DIMENSIONS: mm 		TOLERANCES UNLESS OTHERWISE SPECIFIED: 0 PLC ± 1 PLC ± 2 PLC ± 3 PLC ± 4 PLC ± ANGLES ± FINISH		DWN: R. STAKEM 12FEB2015 CHK: G. BAILEY 12FEB2015 APVD: T. ELBIN 12FEB2015 NAME: Ocean Side Feed Applicator SIZE: A1 CAGE CODE: 00779 DRAWING NO: 2151417 SCALE: 1:2 SHEET: 2 of 4 REV: B		TE Connectivity Harrisburg, PA 17105-3608	
MATERIAL:				WEIGHT:		RESTRICTED TO:	
Customer Accessible Production Drawing							

PART NUMBER	REVISION	DESCRIPTION	FEED TYPE
2-2151417-1	B	FINE CRIMP HEIGHT ADJUST	MECHANICAL
2-2151417-2	B	FINE CRIMP HEIGHT ADJUST	PNEUMATIC
7-2151417-7	A	CRIMP TOOLING KIT	-

PACIFIC VERSION TERMINATOR
INTERFACE ADAPTER



APPLICATOR DATA		
CRIMP	SIZE	TYPE
WIRE	2.00 mm [.079]	F
INSUL	3.94 mm [.155]	O
APPLICATOR INSTRUCTIONS 408-35042		

TERMINAL DATA: LEAR TERMINAL		LEAR CRIMP SPECIFICATION	
TERMINAL NAME: TERMINAL			
WIRE STRIP LENGTH		INSULATION DIAMETER RANGE	
4.20-4.80 mm [1.65-.189 IN]		∅1.20-2.10 mm [.047-.083 IN]	
TERMINAL APPLICATION SPECIFICATION	26806 Rev 1		

TERMINALS APPLIED				SEAL INSULATION DIAMETER RANGE
TE TERMINAL	GWH/LEAR TERMINAL	TE SEAL	GWH/LEAR SEAL	
1949751-1	26806.201.184	1572316-1	16695.627.642	∅1.70 - 2.10
1949751-2	7815102	1949110-1	14448.627.621	∅1.70 - 2.10

WIRE SIZE	CRIMP HEIGHT mm [INCH]	CRIMP HEIGHT REFERENCE SETTING
1.00mm2	1.25+/-0.05 [1.049+/-0.002]	5.5
0.75mm2	1.20+/-0.05 [1.047+/-0.002]	6.0
0.50mm2	1.15+/-0.05 [1.045+/-0.002]	6.5

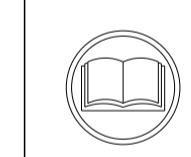

- 1 RECOMMENDED SPARE PARTS
- 2 REFER TO SUPPLIED INSTRUCTION SHEET FOR CLEANING, LUBRICATION AND STORAGE OF APPLICATOR.
- 3 APPLY PART NUMBER 2-23419-6 LOCTITE TO THREADS OF ITEM 242.
- 4 CRIMP HEIGHT REFERENCE SETTING WAS THE SETTING USED WHEN THE APPLICATOR WAS QUALIFIED AT THE FACTORY. ADJUSTMENT MAY BE NECESSARY WHEN RUNNING APPLICATOR IN THE FIELD.
- 5. UNLESS SPECIFIED OTHERWISE TORQUE VALUES SHALL BE USED PER DOCUMENT, 101-35000.
- 6 APPLY TORQ-SEAL IN ALLEN SOCKET TO FILL HOLE AFTER FLAT HD HAS BEEN ADJUSTED TO CORRECT HEIGHT AT QUALIFICATION. APPLY #1-23419-5 LOC-TITE TO THREADS.

***WARNING**
ON INSTALLATION, SET WIRE DISC TO CRIMP HEIGHT REFERENCE SETTING FOR LARGEST WIRE SIZE. CRIMP HEIGHT REFERENCE SETTINGS GREATER THAN THE VALUE SHOWN MAY CAUSE DAMAGE TO THE CRIMP TOOLING, REFER TO THE INSTRUCTION SHEET FOR PROPER SETUP AND ADJUSTMENTS.

PACIFIC VERSION
Shown on sheets 3 of 4 & 4 of 4
(Atlantic version shown on sheets 1 of 4 & 2 of 4)

LOC	DIST	REVISIONS					
A	66	P	LTN	DESCRIPTION	DATE	OWN	APVD
-	-	-	-	SEE SHEET 1	-	-	-

-	1	1	2119082-3	CAM, SNAIL, INSULATION ADJUSTMENT	244	
-	1	1	2079764-1	WASHER, WAVE SPRING, CREST-TO-CREST	243	
3	-	1	2119083-1	RETAINER, INSULATION DIAL	242	
-	1	1	7-18023-7	SCR, SKT HD CAP M3 X 4.0	241	
-	-	1	2119580-1	MECHANICAL FEED ASSEMBLY	239	
-	1	-	2844940-1	AIR FEED MODULE	238	
-	REF	REF	994970-2	COUNTER, MAGNETIC	164	
-	1	-	2119641-2	FEED CAM, AIR FEED	151	
-	1	1	2168083-8	SCR, SKT HD CAP, RoHS, M4 X 16	144	
-	4	4	2168083-9	SCR, SKT HD CAP, RoHS, M4 X 20	143	
-	-	1	2119653-2	FEED CAM, POST FEED	142	
-	1	1	1-1803583-0	APPLICATOR BASIC ASSEMBLY, SF	141	
-	1	1	1803516-1	RAM ASSEMBLY, SF PACIFIC	140	
-	1	1	2844908-1	SCREW, LOCKING	99	
-	1	1	2844907-1	POST, LOCKING	98	
-	2	2	2168083-1	SCR, SKT HD CAP, RoHS, M3 X 8.0	97	
-	1	1	1-690438-0	FRONT STRIP GUIDE	96	
-	1	1	455888-5	SPACER, CRIMPER	82	
-	1	1	1803607-3	DOCUMENTATION PACKAGE	71	
-	1	1	2119740-1	TAG, IDENTIFICATION	67	
-	2	2	2168078-1	SCREW, DRIVE, RH, RoHS, 2 x .188	66	
-	2	2	22281-8	SPRING, COMPRESSION	61	
-	1	1	5-18022-5	SCR, HEX HD CAP, M4 X 6.0	59	
6	-	1	985575-3	SCR, FLT SKT HD CAP M3 X 10.0	57	
-	1	1	1338685-1	PAWL, FEED	56	
-	2	2	1-2168083-0	SCR, SKT HD CAP, RoHS, M4 X 10	53	
-	1	1	5018030-1	NUT, HEX, REG, RoHS, M3	52	
-	1	1	811242-5	BUMPER, HOLD DOWN	51	
-	1	1	690753-2	SPACER, TONKER	50	
-	1	2	18023-9	SCR, SKT HD CAP M4 X 6.0	49	
-	-	1	2119652-1	FEED CAM, PRE FEED	48	
-	1	1	1803602-1	SCR, BHSC, RoHS (M8 X 25)	41	
-	1	1	2-1752356-0	SUPPORT, TERMINAL	34	
-	2	2	2079383-5	SCR, BHSC, RoHS (M4 X 20)	33	
-	2	2	3-2844962-0	SPACER, CYLINDRICAL, STRIP GUIDE	30	
-	1	1	2844992-3	ASSEMBLY, STRIP GUIDE	29	
-	1	1	455888-3	SPACER, CRIMPER	28	
-	2	2	2-18032-5	SCR, SET, FLT PNT, M5 X 20.0	27	
-	1	1	356835-1	LEVER, DRAG RELEASE	26	
-	1	1	240792-1	DRAG, TERMINAL	25	
-	1	1	1320928-2	STRIP GUIDE	24	
-	1	1	980371-4	SCR, SKT HD SHLDR 5.0 DIA X 6.0	23	
-	1	1	2168083-2	SCR, SKT HD CAP, RoHS, M4 X 8.0	21	
-	2	2	1-18028-2	WASHER, FLAT, REG M4	20	
-	1	1	2119533-1	STRIPPER, SIDE FEED	19	
7	-	1	2119806-1	INSERT, SHEAR	13	
-	1	1	3-22280-3	SPRING, COMPRESSION	12	
-	1	1	1-356885-4	STOP, SHEAR	11	
8	-	1	2119805-1	SHEAR HOLDER, FRONT	10	
8	-	1	318707-1	FLOATING SHEAR, FRONT	9	
8	1	1	1	6-1633138-5	ANVIL, COMBINATION	8
-	1	1	3-240641-8	SPACER	7	
-	-	-	-	-	6	
-	1	1	2119781-1	DEPRESSOR, SHEAR	5	
-	1	1	238011-4	BLOCK, CRIMPER SPACER	4	
8	1	1	1	2-2119784-9	CRIMPER, INSULATION O PREMIUM	3
8	-	1	1	1-455888-3	SPACER, CRIMPER	2
8	1	1	1	2-1633738-8	CRIMPER, WIRE	1

DIMENSIONS:		TOLERANCES UNLESS OTHERWISE SPECIFIED:		MATERIAL:		FINISH:		WEIGHT:		SCALE:	
mm	0 PLC ±	1 PLC ±	2 PLC ±	3 PLC ±	4 PLC ±	ANGLES	FINISH			1:2	SHEET 3 OF 4
APPLICATOR SPEC		APPLICATION SPEC		MATERIAL		FINISH		WEIGHT		SCALE	
APPLICATOR SPEC		APPLICATION SPEC		MATERIAL		FINISH		WEIGHT		SCALE	

STE TE Connectivity
Harrisburg, PA 17105-3608

NAME: Ocean Side Feed Applicator

SIZE: A1 CAGE CODE: 00779 DRAWING NO: 2151417

Customer Accessible Production Drawing

LOC	DIST	REVISIONS					
A	66	P	LTN	DESCRIPTION	DATE	OWN	APVD
		-		SEE SHEET 1			

FEED TYPE MECHANICAL

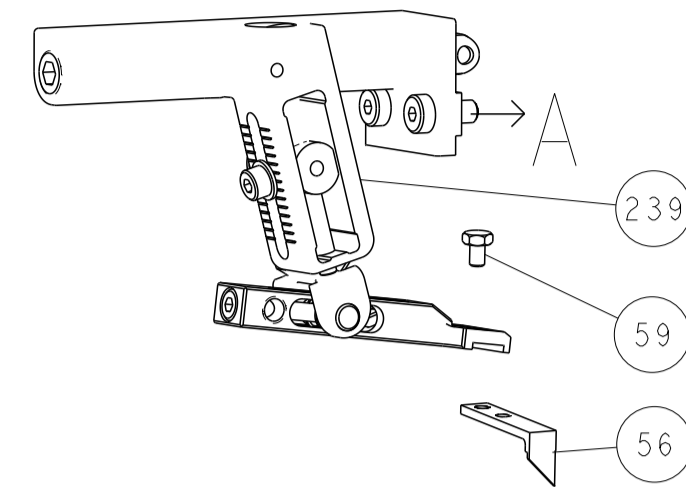

PNEUMATIC

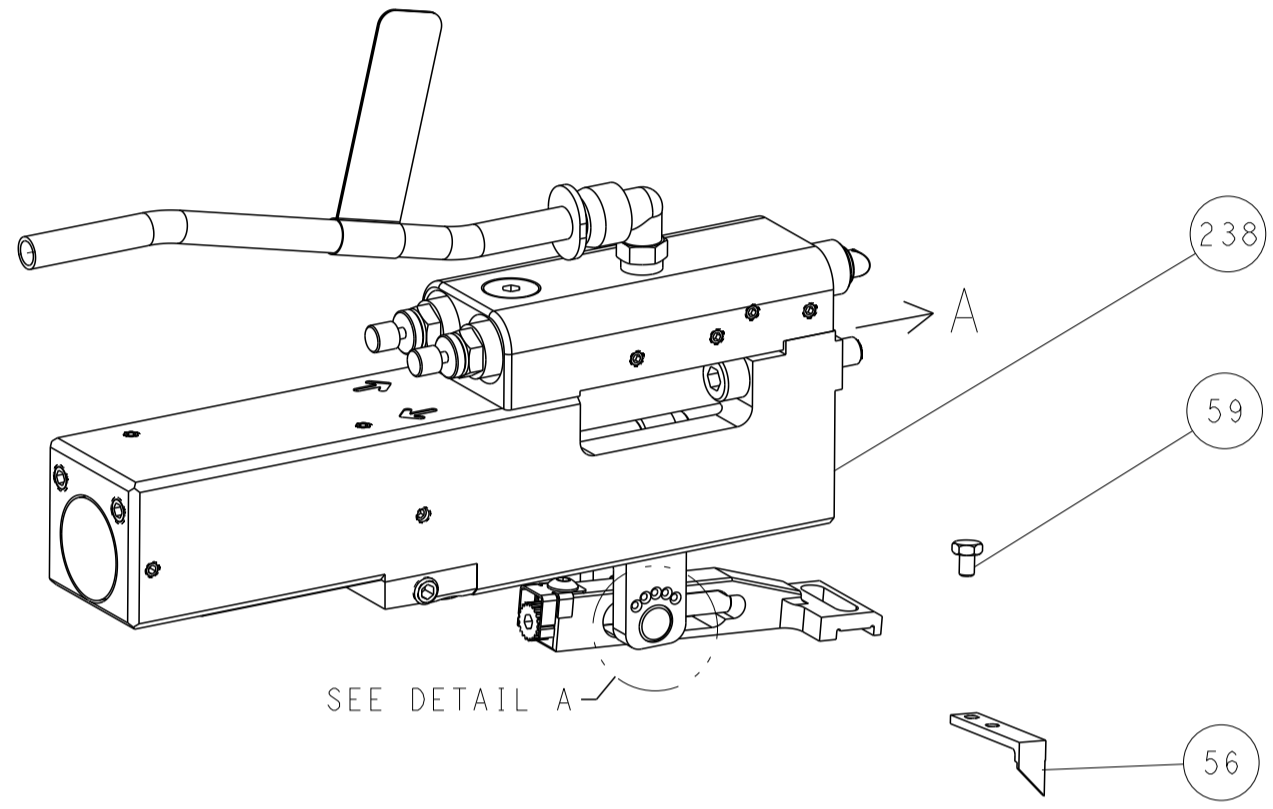

FEED SPRING SETTING POSITION (SHOWN FROM REAR SIDE)

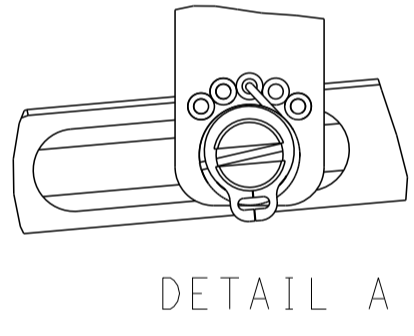

DETAIL A

CAM POSITIONS

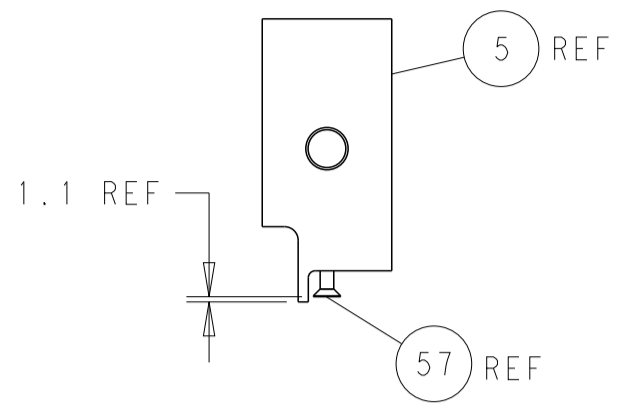
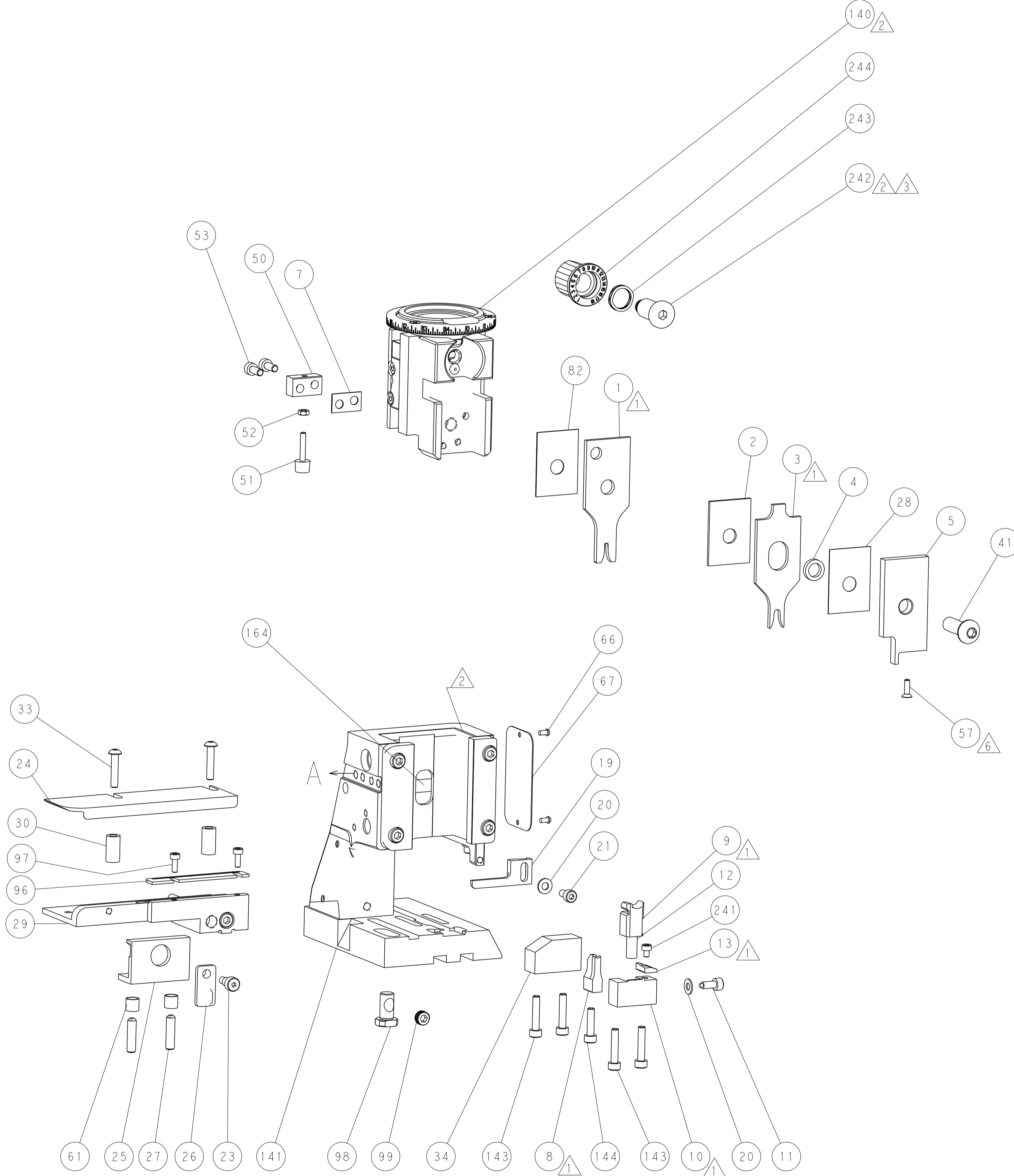
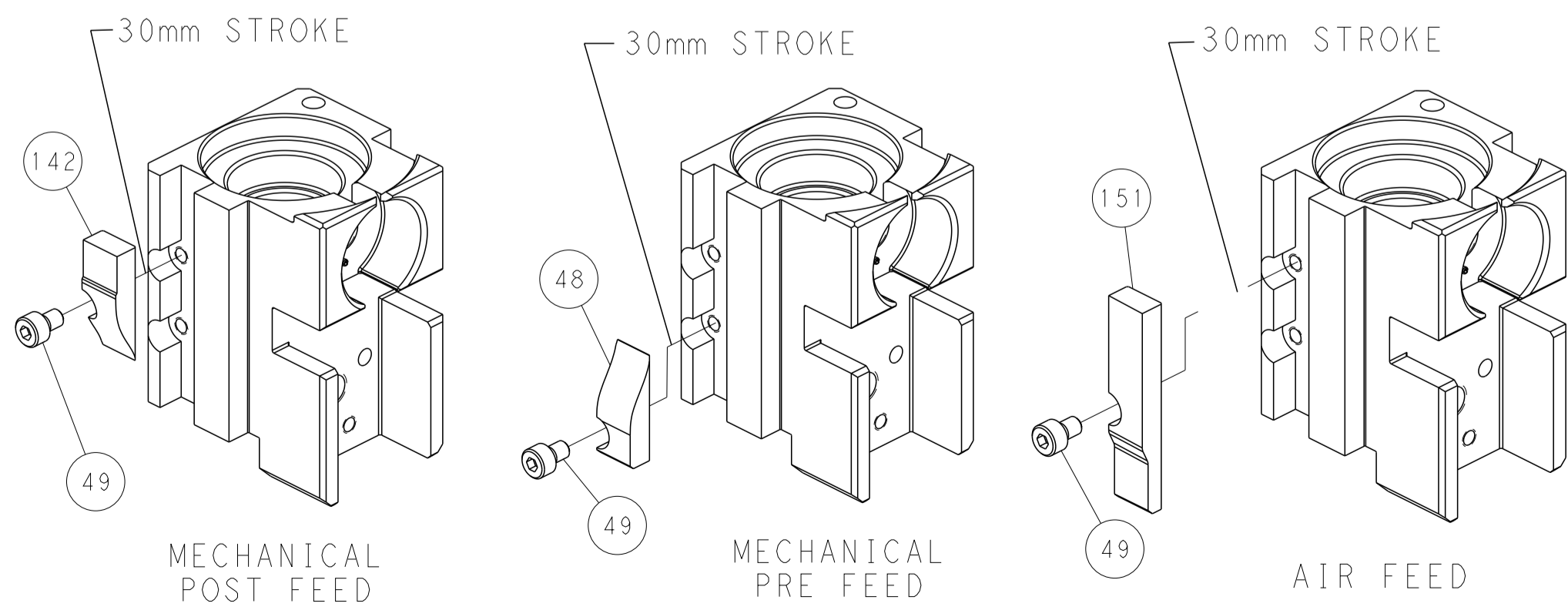

SHEAR DEPRESSOR DETAIL

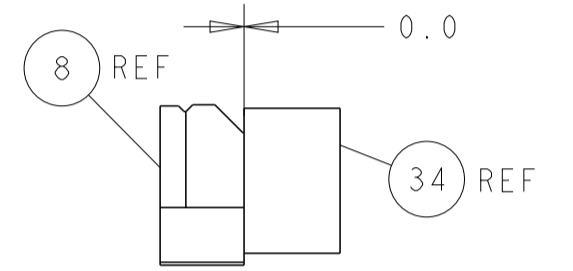

TERMINAL SUPPORT LOCATION

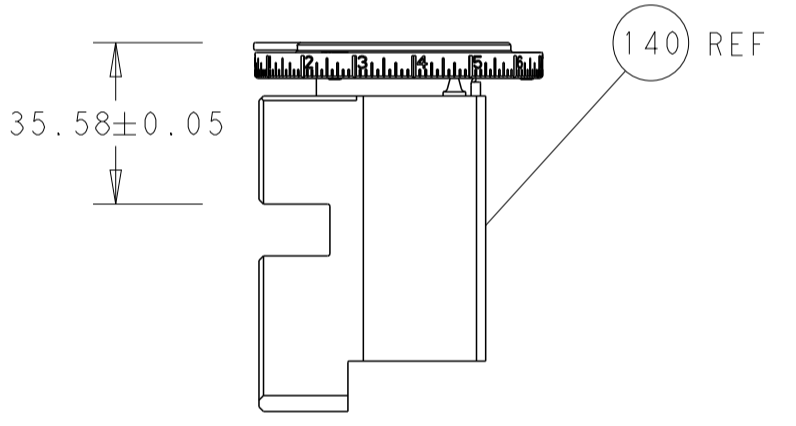

RAM SET-UP

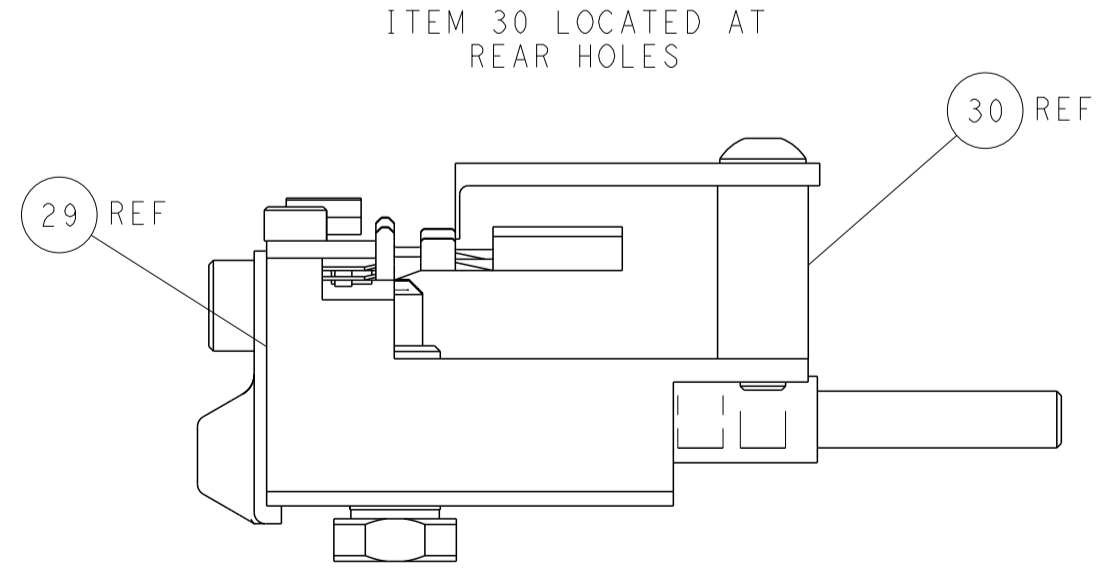

FEED TRACK POSITION GUIDE BY WIRE BARREL

PACIFIC VERSION
 Shown on sheets 3 of 4 & 4 of 4
 (Atlantic version shown on sheets 1 of 4 & 2 of 4)

DIMENSIONS: mm 		TOLERANCES UNLESS OTHERWISE SPECIFIED: 0 PLC ± 1 PLC ± 2 PLC ± 3 PLC ± 4 PLC ± ANGLES ± FINISH ±		DWN: STAKEM 12FEB2015 CHK: G. BAILEY 12FEB2015 APVD: T. ELBIN 12FEB2015 PRODUCT SPEC APPLICATION SPEC WEIGHT SCALE: 1:2		NAME: Ocean Side Feed Applicator SIZE: A1 CAGE CODE: 00779 DRAWING NO: 2151417 SHEET 4 OF 4 REV B	
-----------------------	--	---	--	---	--	--	--