

PAGE 1/2

ISSUE 22-03-22

SERIE : DPDT

PART NUMBER : R577413100

RF CHARACTERISTICS

Frequency range : **0 - 18 GHz**  
 Impedance : **50 Ohms**

Frequency (GHz)	DC - 3	3 - 8	8 - 12.4	12.4 - 18
VSWR max	<b>1.20</b>	<b>1.30</b>	<b>1.40</b>	<b>1.50</b>
Insertion loss max	<b>0.20 dB</b>	<b>0.30 dB</b>	<b>0.40 dB</b>	<b>0.50 dB</b>
Isolation min	<b>80 dB</b>	<b>70 dB</b>	<b>65 dB</b>	<b>60 dB</b>
Average power (*)	<b>240 W</b>	<b>150 W</b>	<b>120 W</b>	<b>100 W</b>

ELECTRICAL CHARACTERISTICS

Actuator : **FAILSAFE**  
 Nominal current \*\* : **140 mA**  
 Actuator voltage (Vcc) : **28V (24 to 30V)**  
 Terminals : **solder pins (250°C max. / 30 sec.)**  
 TTL inputs (E) - High level : **2.2 to 5.5 V / 800µA at 5.5 V**  
 - Low level : **0 to 0.8 V / 20µA at 0.8 V**

MECHANICAL CHARACTERISTICS

Connectors : **SMA female per MIL-C 39012**  
 Life : **2.5 million cycles**  
 Switching Time\*\*\* : **< 15 ms**  
 Construction : **Splashproof**  
 Weight : **< 100 g**

ENVIRONMENTAL CHARACTERISTICS

Operating temperature range : **-40°C to +85°C**  
 Storage temperature range : **-55°C to +85°C**

(\* Average power at 25°C per RF Path)

(\*\* At 25° C ±10%)

(\*\*\* Nominal voltage ; 25° C)



PAGE 2/2

ISSUE 22-03-22

SERIE : DPDT

PART NUMBER : R577413100

DRAWING

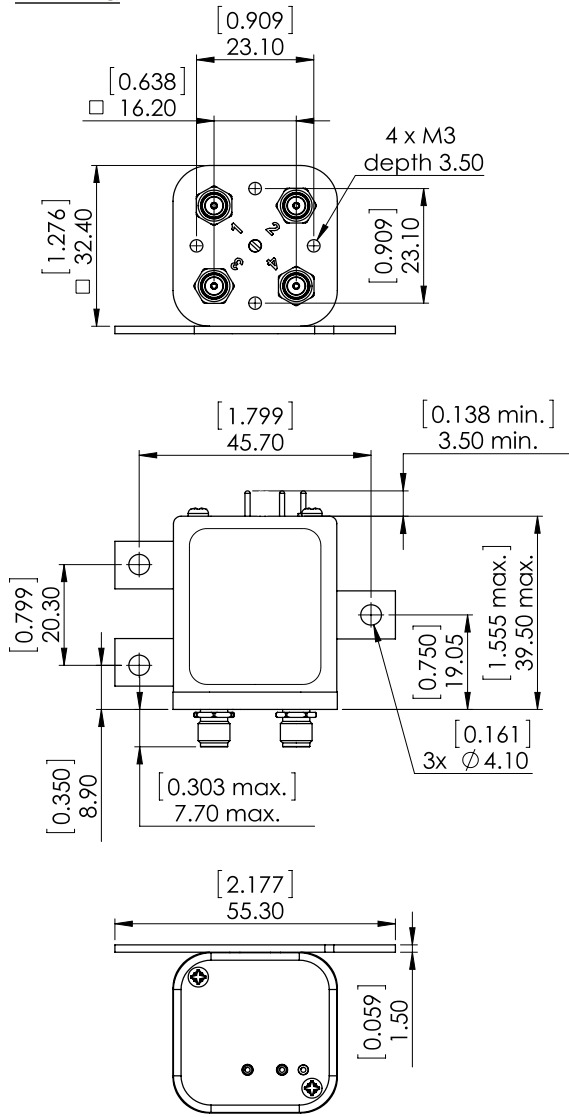

General tolerances : ±0,5 mm [0,02 in]



**LABEL**

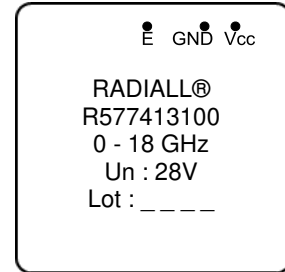

SCHEMATIC DIAGRAM

Position : De energized

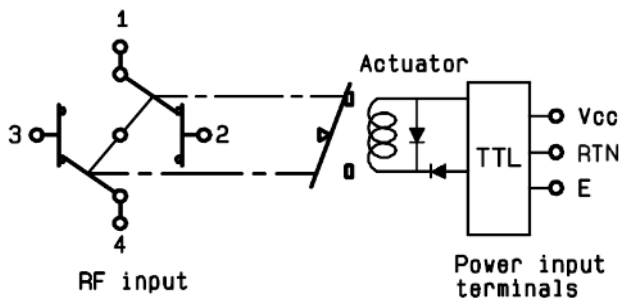

TTL input	RF Continuity
E = 1	1 ↔ 3 / 2 ↔ 4
E = 0	1 ↔ 2 / 3 ↔ 4