

SECTION Y-Y

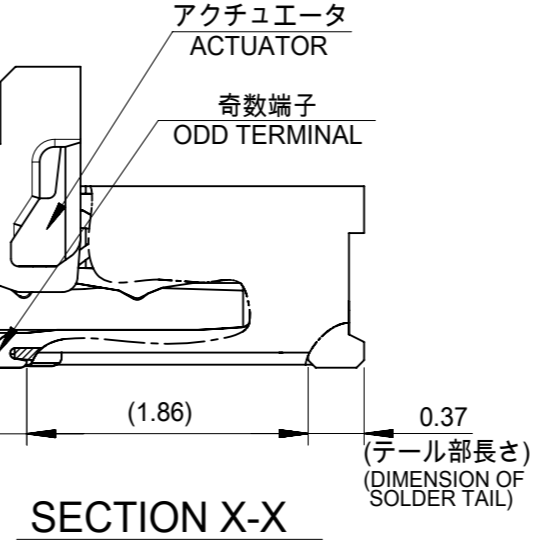

SECTION X-X

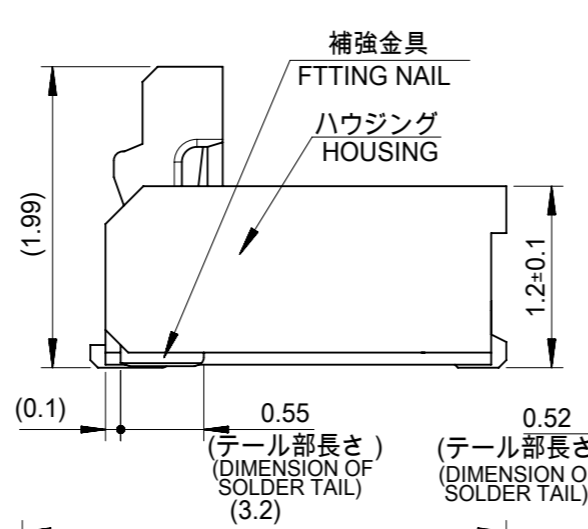
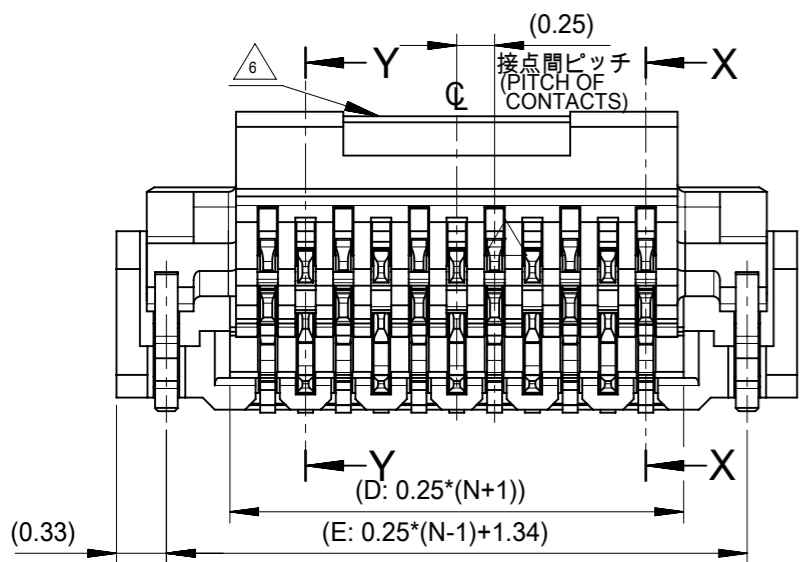
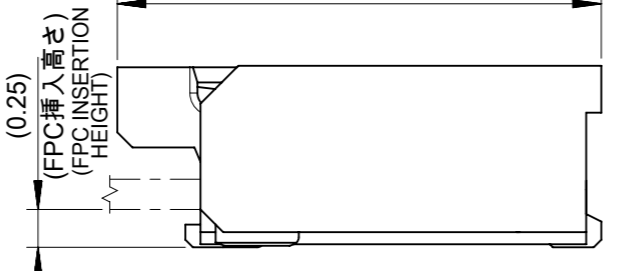

アクチュエータ閉じ位置
ACTUATOR CLOSED POSITION

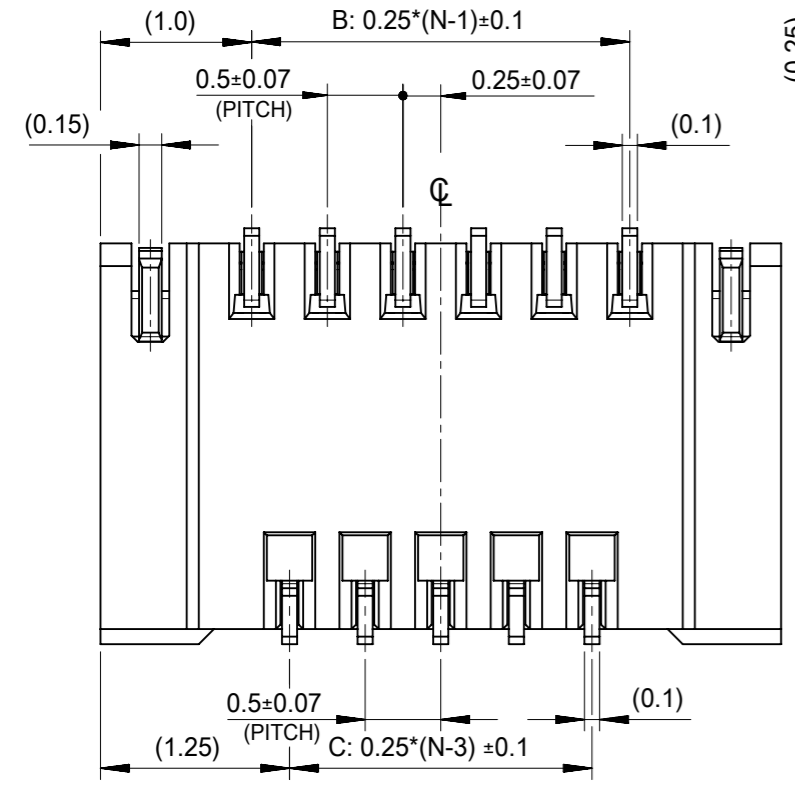

注記 NOTES

1. 使用材料 MATERIALS
 ハウジング : 液晶ポリマー(UL94V-0、黒色)
 アクチュエータ : ポリアミド樹脂(UL94V-0、ベージュ)
 奇数端子 : リン青銅
 偶数端子 : リン青銅
 補強金具 : リン青銅
 HOUSING : G.F. LCP (BLACK)
 ACTUATOR : G.F. POLYAMIDE (BEIGE)
 ODD TERMINAL : PHOSPHOR BRONZE
 EVEN TERMINAL : PHOSPHOR BRONZE
 FITTING NAIL : PHOSPHOR BRONZE
2. メッキ仕様 PLATING
 端子 TERMINAL
 テール部 : 金メッキ
 接点部 : 金メッキ 0.1µm 以上
 下地 : ニッケルメッキ 1.0 µm 以上
 TAIL AREA : Gold PLATING
 CONTACT AREA : Gold PLATING 0.1µm MINIMUM
 UNDER PLATING : Nickel PLATING 1.0µm MINIMUM
- 金具 FITTING NAIL
 全面 : スズメッキ 1.0 µm 以上
 下地 : ニッケルメッキ 1.0 µm 以上
 ALL OVER : Tin PLATING 1.0µm MINIMUM
 UNDER PLATING : Nickel PLATING 1.0µm MINIMUM
- △3 端子、補強金具のコプラナリティーは0.1以下とする
 COPLANALITY OF SOLDER TAILS AND FITTING NAILS : 0.1MAX.
4. 一般公差 : ±0.3
 GENERAL TOLERANCES: ±0.3
5. ELV及びRoHS適合品
 ELV AND RoHS COMPLIANT
- △6 ゲート部形状とする
 本形状は極数により異なります
 THIS SHAPE IS FOR GATE
 IT DEPENDS ON THE NUMBER OF CIRCUITS

14.34	13.5	12.5	13	15	503300-5310	53
11.84	11	10	10.5	12.5	503300-4310	43
11.34	10.5	9.5	10	12	503300-4110	41
10.34	9.5	8.5	9	11	503300-3710	37
8.84	8	7	7.5	9.5	503300-3110	31
8.34	7.5	6.5	7	9	503300-2910	29
6.34	5.5	4.5	5	7	503300-2110	21
5.34	4.5	3.5	4	6	503300-1710	17
E	D	C	B	A	ORDER NO.	CIRCUITS
EMBOSSED TAPE PACKAGE						
CONNECTOR SERIES NO.						503300-**18

THIS DRAWING CONTAINS INFORMATION THAT IS PROPRIETARY TO MOLEX ELECTRONIC TECHNOLOGIES, LLC AND SHOULD NOT BE USED WITHOUT WRITTEN PERMISSION

DIMENSION UNITS	SCALE	CURRENT REV DESC:	
mm	20:1		
GENERAL TOLERANCES (UNLESS SPECIFIED)			
ANGULAR TOL	± 1.0 °		
4 PLACES	± 0.3	EC NO: 749229	
3 PLACES	± 0.3	DRWN: RAJAGN	2023/05/02
2 PLACES	± 0.3	CHK'D: HSHIMOMYAMA	2023/05/11
1 PLACE	± 0.3	APPR: YNAITO	2023/05/11
0 PLACES	± 0.3	INITIAL REVISION:	
DRAFT WHERE APPLICABLE MUST REMAIN WITHIN DIMENSIONS		DRWN: MNIITA	2010/08/23
THIRD ANGLE PROJECTION		APPR: SHOSHIKAWA	2010/08/27
DRAWING	SERIES	MATERIAL NUMBER	CUSTOMER
A3-SIZE	503300	SEE TABLE	GENERAL

molex

0.25 PITCH FPC CONN. E/O
HGT=1.2 UPR CONTACT TYPE LOW-HALOGEN

PRODUCT CUSTOMER DRAWING

DOCUMENT NUMBER	DOC TYPE	DOC PART	REVISION
SD-503300-001	PSD	001	F
SHEET NUMBER		1 OF 2	

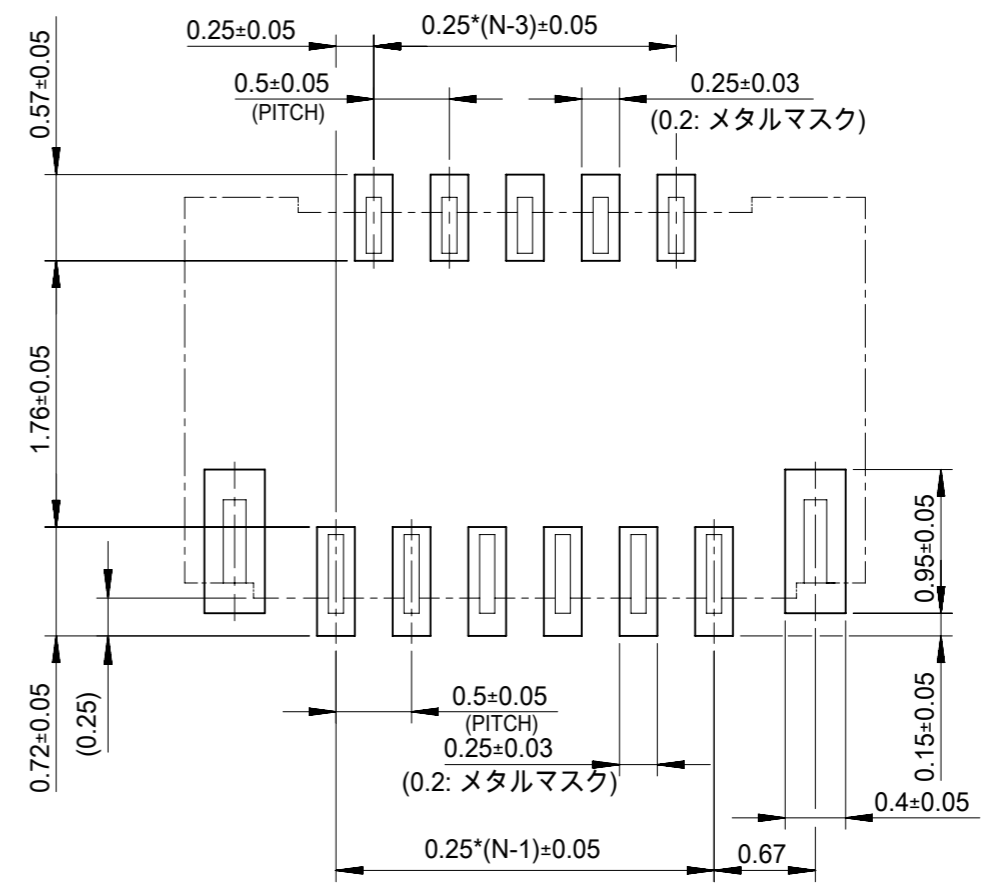
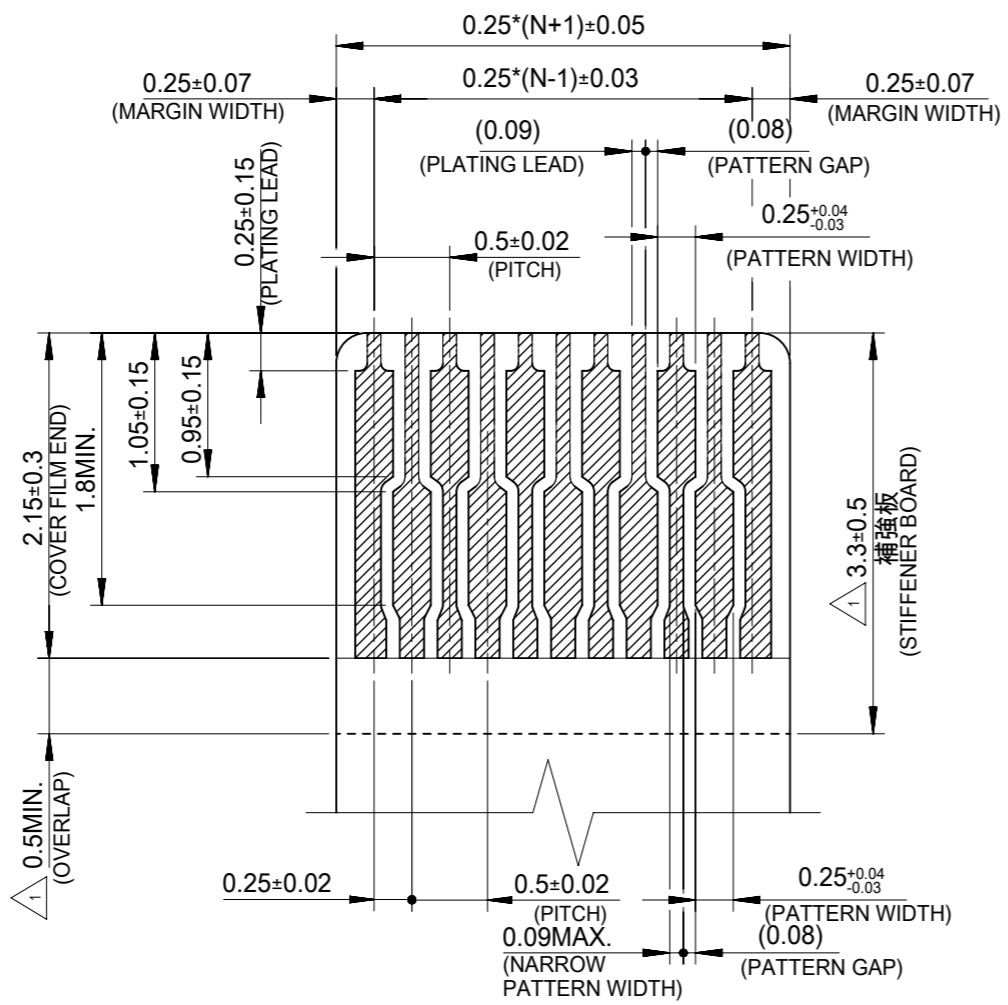

適合するFPC推奨寸法
APPLICABLE FPC
RECOMMENDED DIMENSION

(端子部仕上がり厚さ : 0.2±0.03)
(THICKNESS: 0.2±0.03)

注記 NOTES

- 1 補強板長さが図面通り確保できない場合は、カバーレイと補強板のオーバーラップ寸法を0.5mm以上としてください
WHEN STIFFENER BOARD DIMENSION CAN NOT SECURE AS DRAWING, PLEASE GIVE THE OVERLAP SIZE OF COVER FILM AND STIFFENER BOARD AS 0.5mm MINIMUM
- 2 推奨ペースト厚 : 100µm
推奨マスク開口率 : 80%
RECOMMEND SCREEN THICKNESS : 100µm
RECOMMEND SCREEN OPEN RATIO : 80%

- 3 FPCパターンのメッキ仕様は
金メッキ : 0.1µm以上
下地ニッケルメッキ : 2~6µm
FPC PATTERN PLATING
GOLD PLATING : 0.1µm MINIMUM
NICKEL UNDER PLATING : 2~6µm

- 4 FPCについて(ABOUT FPC)
抜き方向は、導体側から補強板側を推奨します
補強板材質は、ポリイミドを推奨します
接着剤は熱硬化接着剤を推奨します
なお、接着剤の接点部への付着は導通不良の原因となりますので染み出しがないよう、お願いします
RECOMMENDED PUNCHER DIRECTION:
FROM CONDUCTOR SIDE TO STIFFENER BOARD SIDE
RECOMMENDED MATERIAL:
STIFFENER BOARD: POLYIMIDE
BONDING AGENT: THERMOSETTING AGENT
PLEASE PUT APPROPRIATE AMOUNT OF ADHESIVE ON THE CONTACT AREA BECAUSE THE EXTRA ADHESIVE MAY CAUSE THE DEFECT IN ELECTRICAL CONTINUITY

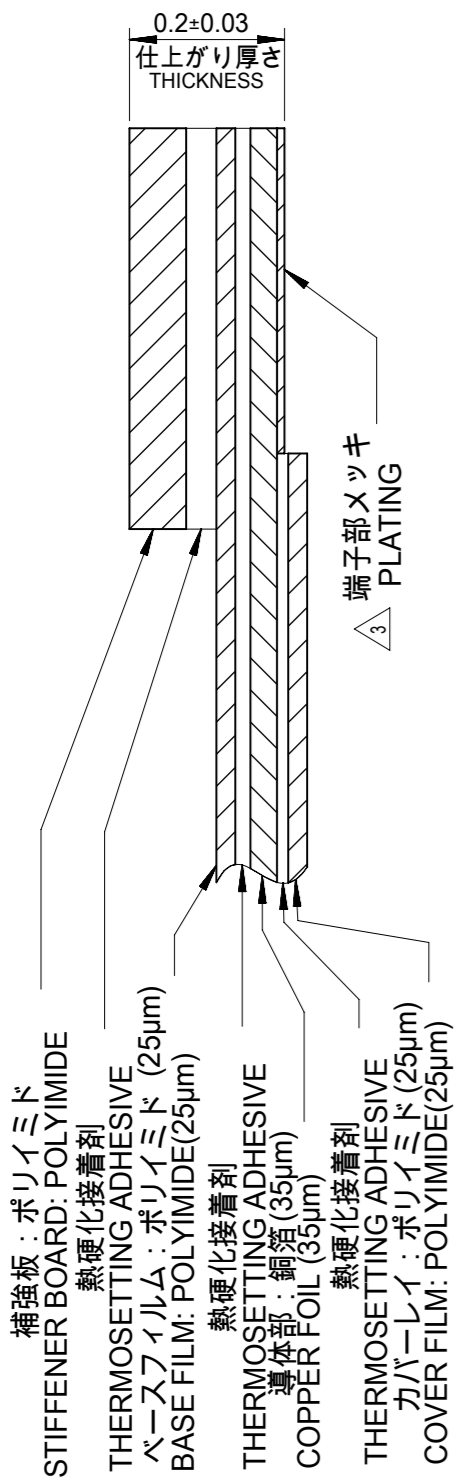

FPC 構成材料例

EXAMPLE OF FPC
COMPOSITION MATERIAL

THIS DRAWING CONTAINS INFORMATION THAT IS PROPRIETARY TO MOLEX ELECTRONIC TECHNOLOGIES, LLC AND SHOULD NOT BE USED WITHOUT WRITTEN PERMISSION													
DIMENSION UNITS		SCALE		CURRENT REV DESC.									
mm		20:1		<div style="text-align: center; font-size: 24pt; font-weight: bold;">molex</div> <p>0.25 PITCH FPC CONN. E/O HGT=1.2 UPR CONTACT TYPE LOW-HALOGEN</p> <p>PRODUCT CUSTOMER DRAWING</p>									
GENERAL TOLERANCES (UNLESS SPECIFIED)													
ANGULAR TOL ± 1.0°													
4 PLACES ± 0.3		EC NO: 749229								DRWN: RAJAGN		2023/05/02	
3 PLACES ± 0.3		CHK'D: HSHIMOYAMA								APPR: YNAITO		2023/05/11	
2 PLACES ± 0.3		INITIAL REVISION:		DRWN: MNIITA		2010/08/23							
1 PLACE ± 0.3		APPR: SHOSHIKAWA		2010/08/27		DOCUMENT NUMBER		DOC TYPE DOC PART REVISION					
0 PLACES ± 0.3		DRAFT WHERE APPLICABLE MUST REMAIN WITHIN DIMENSIONS		THIRD ANGLE PROJECTION		DRAWING		SERIES					
MATERIAL NUMBER		CUSTOMER		SHEET NUMBER		<div style="text-align: center; font-size: 18pt; font-weight: bold;">SD-503300-001</div>							
SEE SHEET 1		GENERAL		2 OF 2									

注記 NOTES

- 1. 製品詳細寸法については図面 SD-503300-001 を参照下さい。
RE DETAILED DIMENSION, SEE SD-503300-001
- 2. 梱包数量 : 3000 個 / リール
NUMBER OF CONNECTORS : 3000 PCS/REEL
- 3. リードテープ長さ LEAD TAPE LENGTH

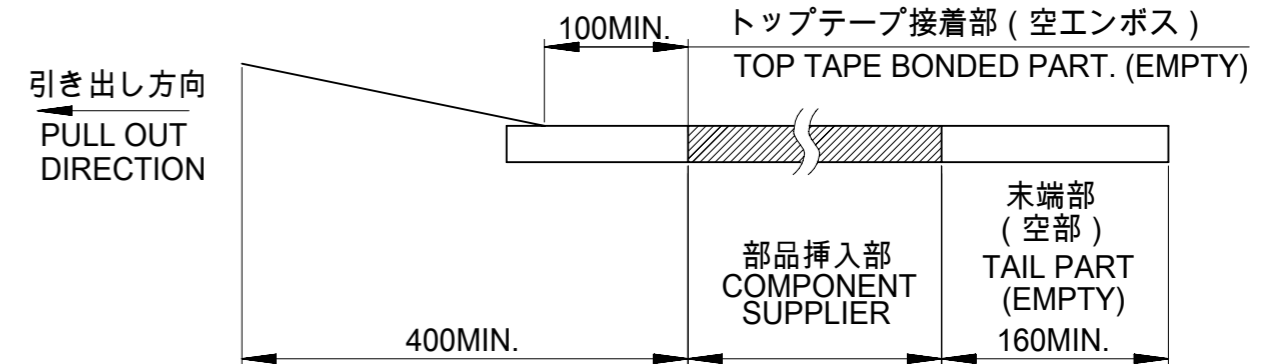

4. 材料 MATERIAL

キャリアテープ (CARRIER TAPE) : ポリスチレン (POLYSTYRENE)
 トップテープ (TOP TAPE) : PET, PE, PEF
 リール (REEL) : ポリスチレン (PS) <リサイクル材を含む>
 POLYSTYRENE (PS) <RECYCLE MATERIAL CONTAINED>

- 5. カバーテープの剥離強度については、IEC60286-3 に準拠
COVER TAPE PEEL FORCE IS DEFINED BY IEC60286-3.

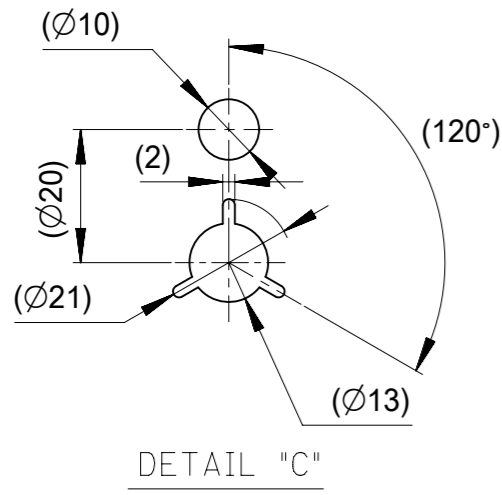
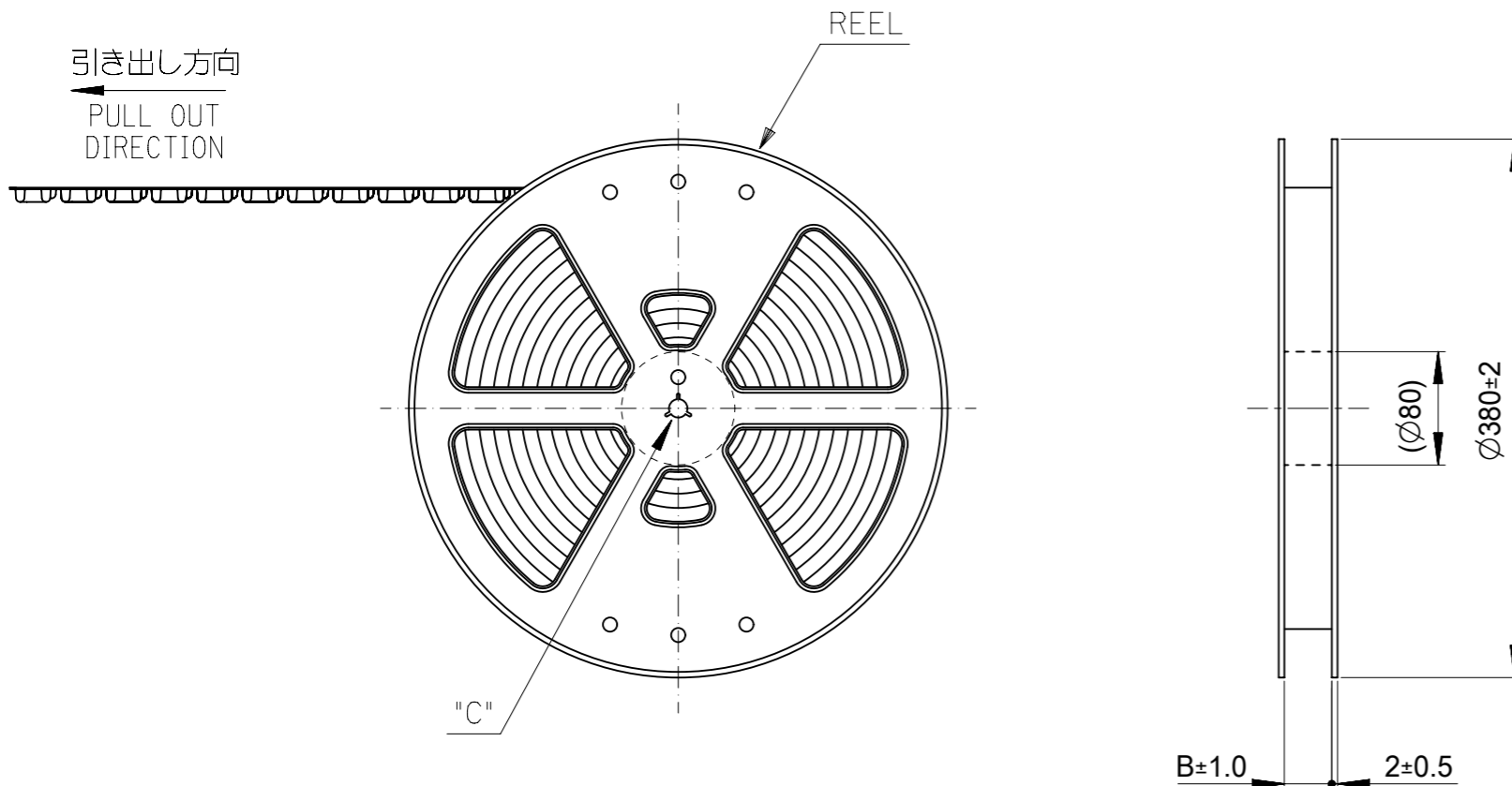

CONNECTOR SERIES NO. 503300-**10

THIS DRAWING CONTAINS INFORMATION THAT IS PROPRIETARY TO MOLEX ELECTRONIC TECHNOLOGIES, LLC AND SHOULD NOT BE USED WITHOUT WRITTEN PERMISSION		CURRENT REV DESC:		molex	
DIMENSION UNITS	SCALE	EC NO: 749229			
mm	1:1	DRWN: RAJAGN 2023/05/02		0.25MM FPC CONN. E/O H=1.2 HSG ASSY UPR EMBOSSED TAPE PACKAGE	
GENERAL TOLERANCES (UNLESS SPECIFIED)		CHK'D: HSHIMOYAMA 2023/05/11			
ANGULAR TOL ± 1.0°		APPR: YNAITO 2023/05/11		PRODUCT CUSTOMER DRAWING	
4 PLACES ± 0.2		INITIAL REVISION:		DOCUMENT NUMBER	
3 PLACES ± 0.25		DRWN: MNIITA 2010/08/24		SD-503300-002	
2 PLACES ± 0.3		APPR: SHOSHIKAWA 2010/08/27		DOC TYPE	
1 PLACE ±		THIRD ANGLE PROJECTION		PSD	
0 PLACES ±		DRAWING		DOC PART	
DRAFT WHERE APPLICABLE MUST REMAIN WITHIN DIMENSIONS		A3-SIZE		001	
DRAFT WHERE APPLICABLE MUST REMAIN WITHIN DIMENSIONS		SERIES		REVISION	
DRAFT WHERE APPLICABLE MUST REMAIN WITHIN DIMENSIONS		503300		D	
DRAFT WHERE APPLICABLE MUST REMAIN WITHIN DIMENSIONS		MATERIAL NUMBER		SHEET NUMBER	
DRAFT WHERE APPLICABLE MUST REMAIN WITHIN DIMENSIONS		GENERAL		1 OF 3	

GENERAL TOLERANCES (UNLESS SPECIFIED)	
10 UNDER	±0.2
10 OVER 30 UNDER	±0.25
30 OVER	±0.3
ANGULAR	±1°
DRAFT WHERE APPLICABLE MUST REMAIN WITHIN DIMENSIONS	

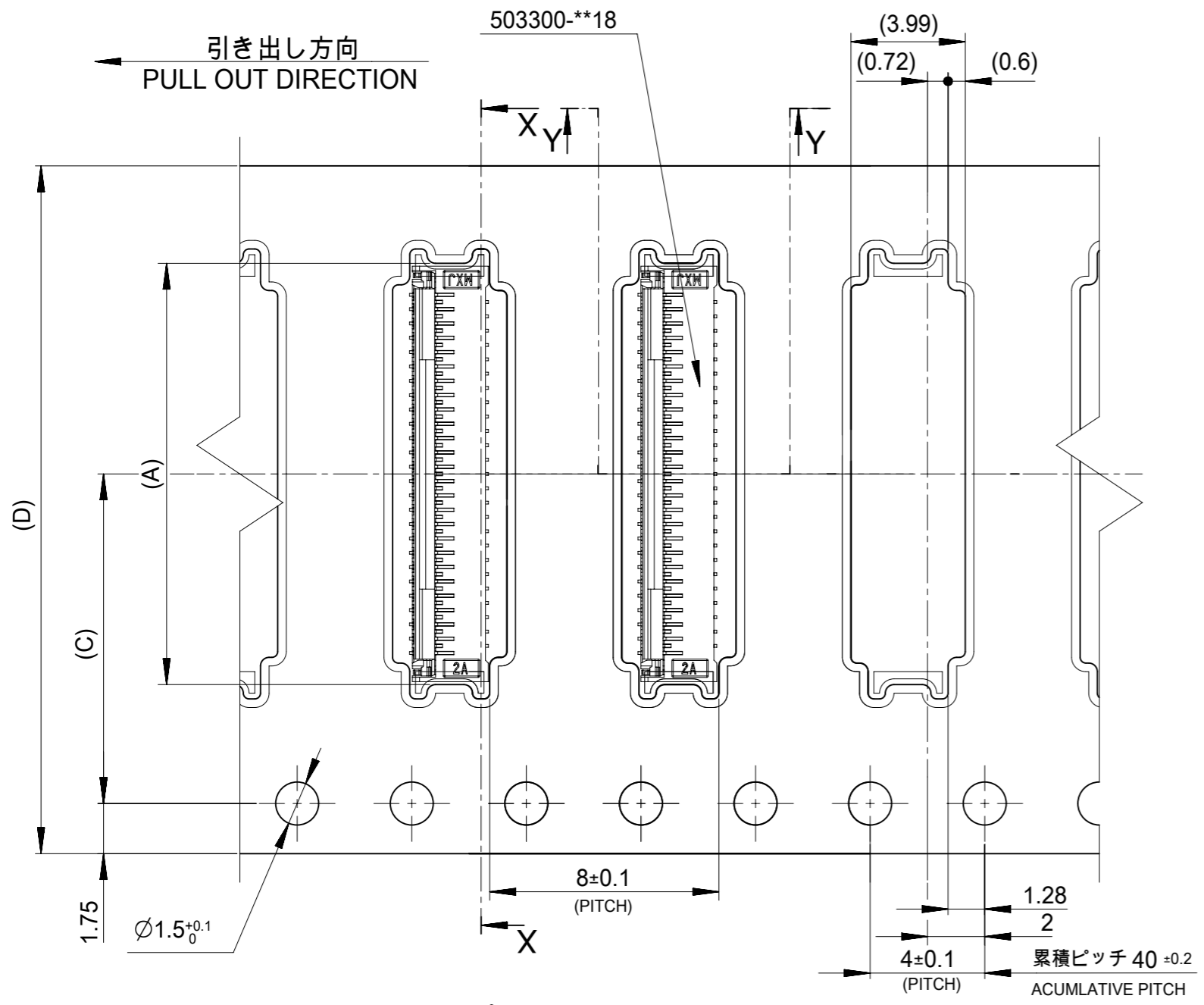

16, 24mm幅キャリアテープ
16, 24mm WIDTH CARRIER TAPE

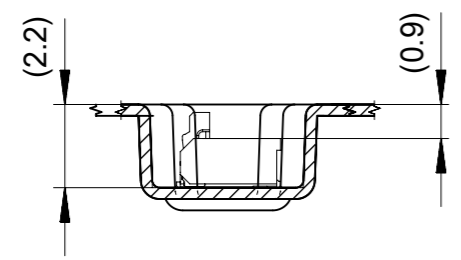

SECTION Y-Y

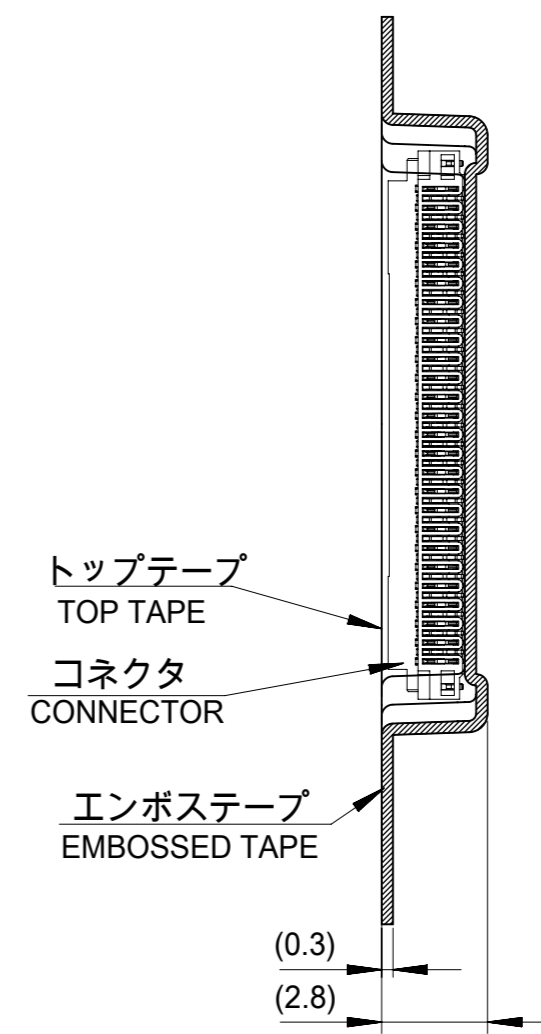

SECTION X-X

24	11.5	25.4	13.7	503300-4310	43
			13.2	503300-4110	41
			12.2	503300-3710	37
			10.7	503300-3110	31
			10.2	503300-2910	29
16	7.5	17.4	8.2	503300-2110	21
			7.2	503300-1710	17
(D) キャリアテープ幅 CARRIER TAPE WIDTH	(C)	B	(A)	オーダー番号 ORDER NO.	極数 CIRCUITS
CONNECTOR SERIES NO.				503300-**10	

GENERAL TOLERANCES (UNLESS SPECIFIED)		DIMENSION UNITS: mm		SCALE: 1:1		CURRENT REV DESC:		molex	
10 UNDER	±0.2	4 PLACES	± 0.2	EC NO: 749229		2023/05/02			
10 OVER 30 UNDER	±0.25	3 PLACES	± 0.25	DRWN: RAJAGN		2023/05/11			
30 OVER	±0.3	2 PLACES	± 0.3	CHK'D: HSHIMOMYAMA		2023/05/11			
ANGULAR	±1°	1 PLACE	±	APPR: YNAITO		INITIAL REVISION:			
DRAFT WHERE APPLICABLE MUST REMAIN WITHIN DIMENSIONS		0 PLACES	±	DRWN: MNIITA		2010/08/24			
		THIRD ANGLE PROJECTION		APPR: SHOSHIKAWA		2010/08/27			
		DRAWING: A3-SIZE		SERIES: 503300		DOCUMENT NUMBER: SD-503300-002			
		MATERIAL NUMBER: GENERAL		CUSTOMER: GENERAL		DOC TYPE: PSD			
		SHEET NUMBER: 2 OF 3		DOC PART: 001		REVISION: D			

10 9 8 7 6 5 4 3 2 1

F
E
D
C
B
A

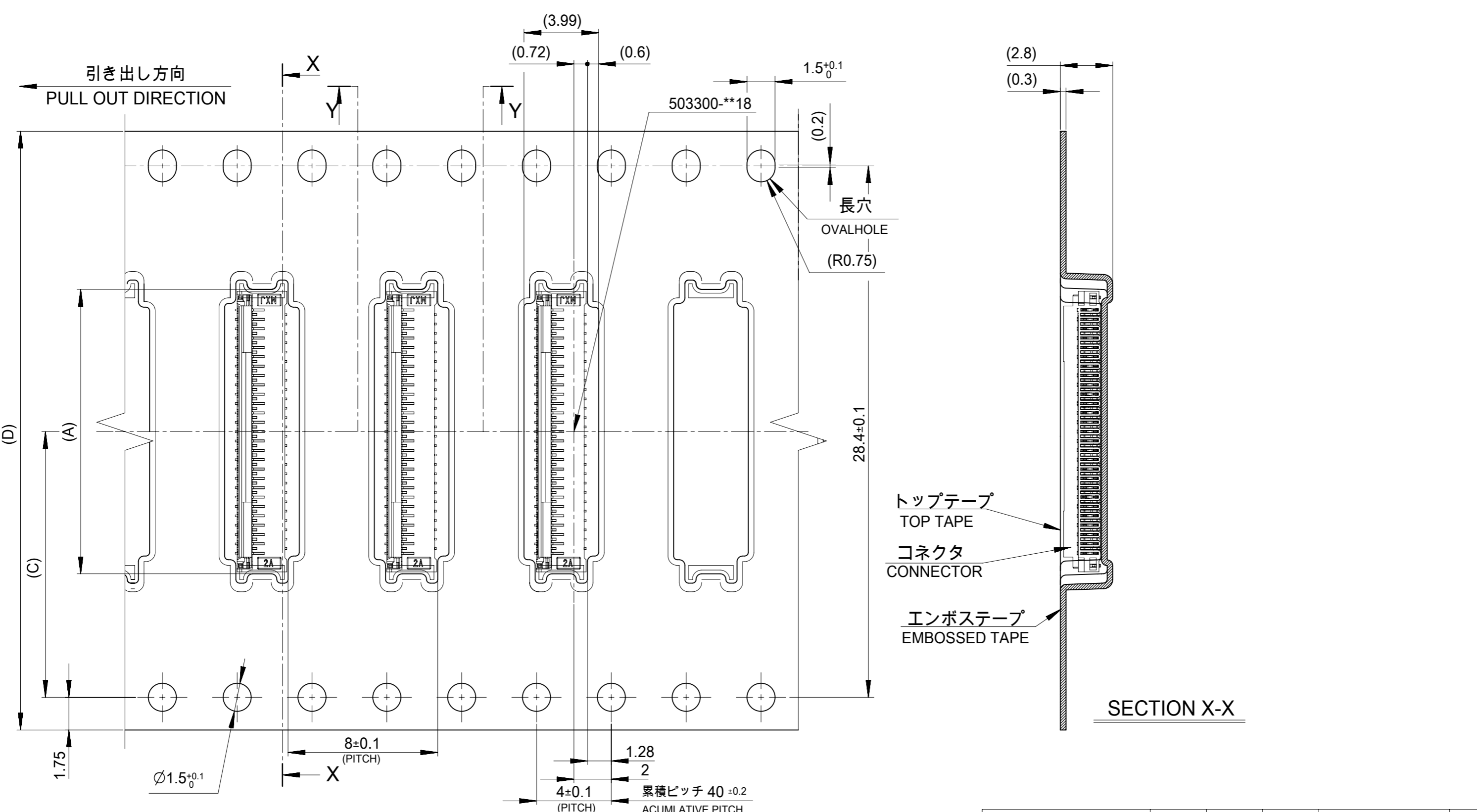

32	14.2	33.4	15.2	503300-5310	53
キャリアテープ幅 CARRIER TAPE WIDTH			(C)	B	(A)
製品番号 MATERIAL NO.			503300-**10		
MODEL NO.			503300-**10		

THIS DRAWING CONTAINS INFORMATION THAT IS PROPRIETARY TO MOLEX ELECTRONIC TECHNOLOGIES, LLC AND SHOULD NOT BE USED WITHOUT WRITTEN PERMISSION					
DIMENSION UNITS mm		SCALE 1:1		CURRENT REV DESC:	
GENERAL TOLERANCES (UNLESS SPECIFIED)					
ANGULAR TOL ± 1.0°					
EC NO: 749229					
DRWN: RAJAGN 2023/05/02					
CHK'D: HSHIMUYAMA 2023/05/11					
APPR: YNAITO 2023/05/11					
INITIAL REVISION:					
DRWN: MNIITA 2010/08/24					
APPR: SHOSHIKAWA 2010/08/27					
DOCUMENT NUMBER		DOC TYPE		DOC PART REVISION	
SD-503300-002		PSD		001 D	
DRAFT WHERE APPLICABLE MUST REMAIN WITHIN DIMENSIONS		THIRD ANGLE PROJECTION		DRAWING SERIES	
		A3-SIZE		503300	
MATERIAL NUMBER		CUSTOMER		SHEET NUMBER	
		GENERAL		3 OF 3	

GENERAL TOLERANCES (UNLESS SPECIFIED)	
10 UNDER	±0.2
10 OVER 30 UNDER	±0.25
30 OVER	±0.3
ANGULAR	±1°
DRAFT WHERE APPLICABLE MUST REMAIN WITHIN DIMENSIONS	

10 9 8 7 6 5 4 3 2 1

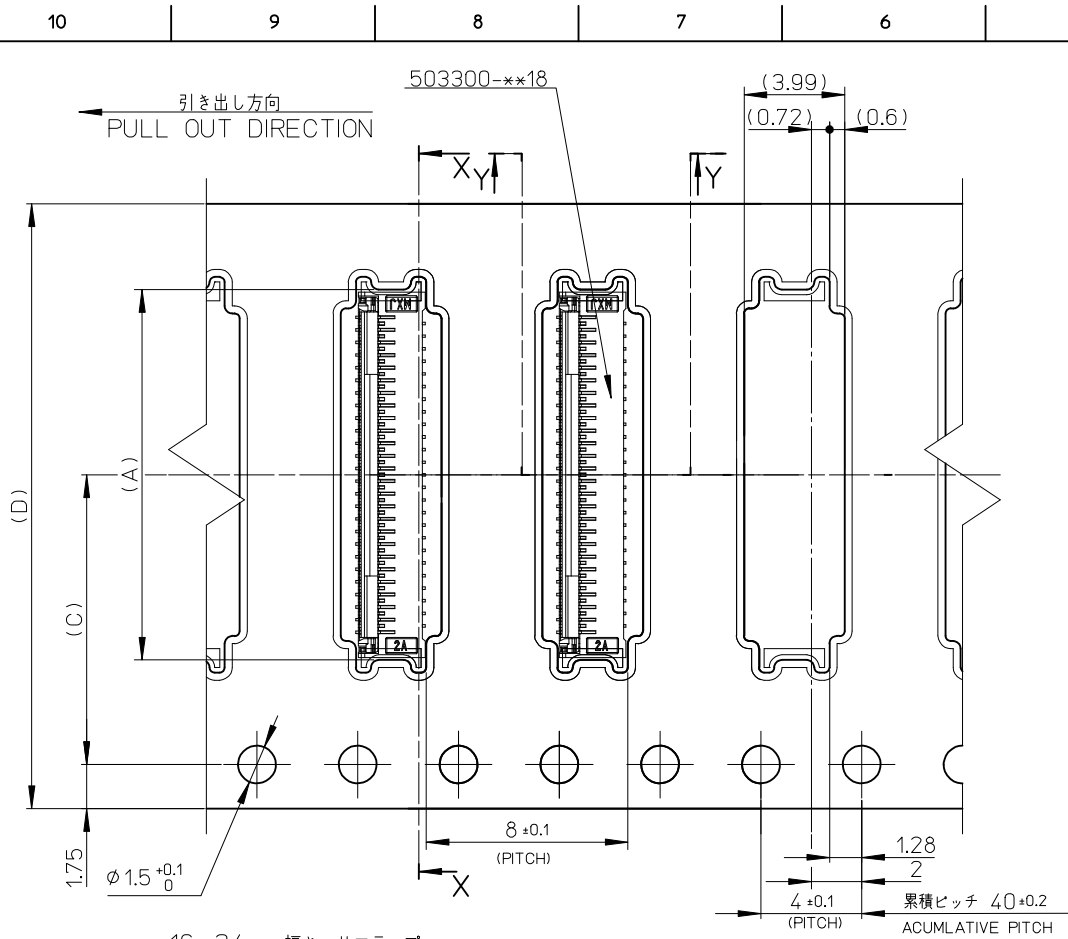

16, 24mm幅キャリアテープ
16, 24mm WIDTH CARRIER TAPE

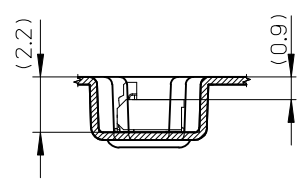

SECTION Y-Y

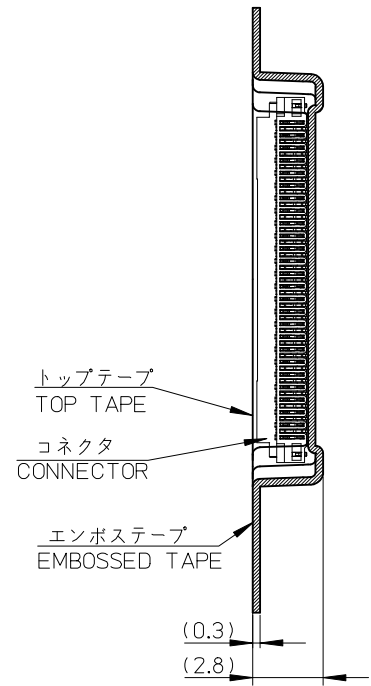

SECTION X-X

24	11.5	25.4	13.7	503300-4310	43
			13.2	503300-4110	41
			12.2	503300-3710	37
			10.7	503300-3110	31
			10.2	503300-2910	29
			8.2	503300-2110	21
(D) キャリアテープ幅 CARRIER TAPE WIDTH	(C)	B	(A)	オーダー番号 ORDER NO.	極数 CIRCUITS

REVISED EC NO: J2014-1201 DRWN: TMORISHITA 2014/01/29 CHKD: KTAHASHI 2014/01/29 APPR: YNOGAWA 2014/02/07	GENERAL TOLERANCES (UNLESS SPECIFIED)		DIMENSION STYLE MM ONLY		SCALE ---	DESIGN UNITS METRIC	CONNECTOR SERIES NO. 503300-**-10		
	10 UNDER	±0.2	DRAWN BY MNIITA		DATE 2010/08/24		TITLE		
	10 OVER 30 UNDER	±0.25	CHECKED BY SHOSHIKAWA		DATE 2010/08/24		0.25MM FPC CONN. E/O H=1.2 HSG ASSY UPR EMBOSSD TAPE PACKAGE		
	30 OVER	±0.3	APPROVED BY SHOSHIKAWA		DATE 2010/08/27		molex		
	ANGULAR ±1 °		MATERIAL NO.		DOCUMENT NO.		SHEET NO.		
DRAFT WHERE APPLICABLE MUST REMAIN WITHIN DIMENSIONS		SIZE A3		SEE CHART				SD-503300-002	
THIS DRAWING CONTAINS INFORMATION THAT IS PROPRIETARY TO MOLEX INCORPORATED AND SHOULD NOT BE USED WITHOUT WRITTEN PERMISSION									

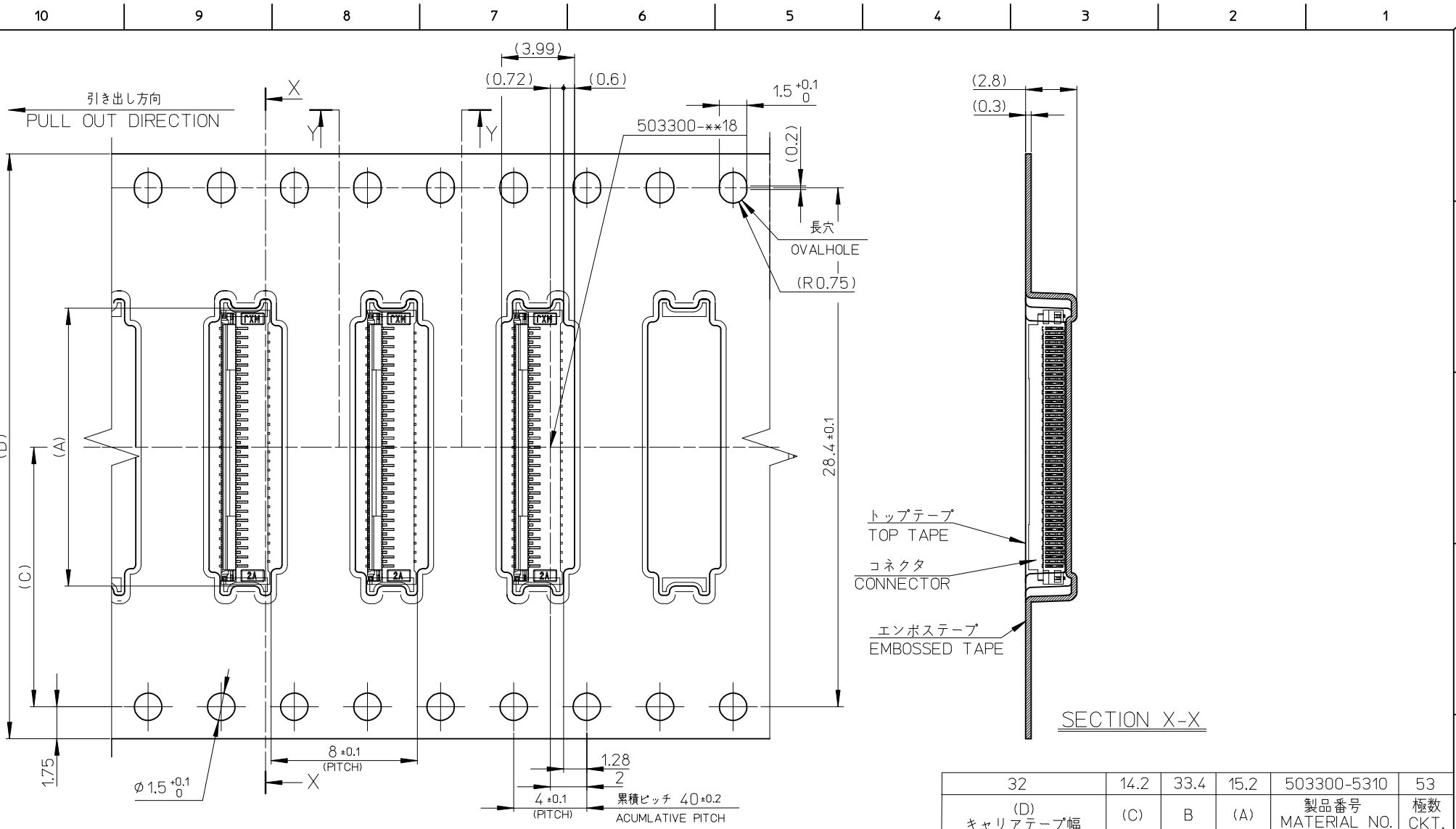

32mm幅キャリアテープ
32mm WIDTH CARRIER TAPE

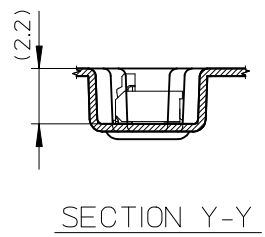

32	14.2	33.4	15.2	503300-5310	53
(D) キャリアテープ幅 CARRIER TAPE WIDTH	(C)	B	(A)	製品番号 MATERIAL NO.	極数 CKT.
MODEL NO.				503300-**10	
DIMENSION STYLE MM ONLY		SCALE 1:1	DESIGN UNITS METRIC	THIRD ANGLE PROJECTION	

REVISED EC NO: J2014-1201 DRWN: TMORISHITA 2014/01/29 CHKD: TAKAHASHI 2014/01/29 APPR: YNOGAWA 2014/02/07	GENERAL TOLERANCES (UNLESS SPECIFIED)	
	10 UNDER	± 0.2
	10 OVER 30 UNDER	± 0.25
	30 OVER	± 0.3
DESCRIPTION	ANGULAR	± 1 °
REV	DRAFT WHERE APPLICABLE MUST REMAIN WITHIN DIMENSIONS	

DRAWN BY MNIITA	DATE 2012/01/05	TITLE 0.25MM FPC CONN. E/O H=1.2 HSG ASSY UPR EMBOSSSED TAPE PACKAGE
CHECKED BY SHOSHIKAWA	DATE 2012/01/05	
APPROVED BY SHOSHIKAWA	DATE 2012/01/05	
MATERIAL NO. SEE CHART	DOCUMENT NO. SD-503300-002	SHEET NO. 3 OF 3
THIS DRAWING CONTAINS INFORMATION THAT IS PROPRIETARY TO MOLEX INCORPORATED AND SHOULD NOT BE USED WITHOUT WRITTEN PERMISSION		