

MATERIALS AND FINISHES

BODY: BRASS  
PLATED TRI-M3

CONTACT: PHOSPHOR BRONZE  
PLATED SILVER

OUTER CONDUCTOR: PHOSPHOR BRONZE  
PLATED TRI-M3

SCREW(STUD): STAINLESS STEEL

INSULATOR: TEFLON

O-RING: SILICONE RUBBER

PERFORMANCE REQUIREMENTS:

FREQUENCY RANGE: DC-12GHz  
TEMPERATURE RANGE: -55-+155°C  
IMPEDANCE: 50 OHM  
WITHSTAND VOLTAGE(AC): 3000V @0.5mA  
RETURN LOSS: <-30dB @DC~4GHz;  
<-26dB @4~6GHz  
PIM3(2x20W): <-166dBC @900MHZ AND 1800MHZ  
WATERPROOF(UNMATED): IP68

MATING CYCLES: 500 MIN  
CONTACT CAPTIVATION:  
AXIAL FORCE: >200N  
RADIAL TORQUE: >30Ncm  
COUPLING TORQUE: 5Nm

PACKAGING BY TRAY

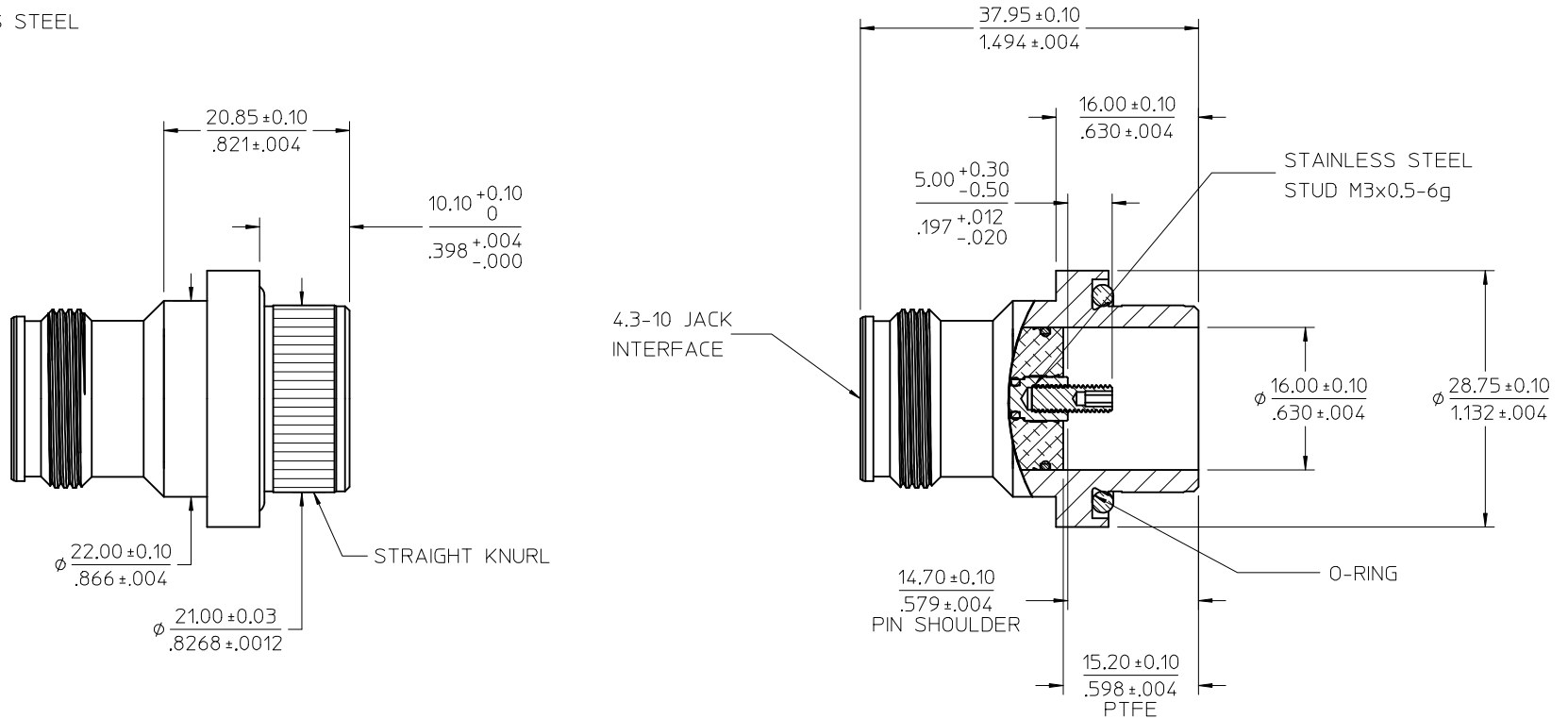
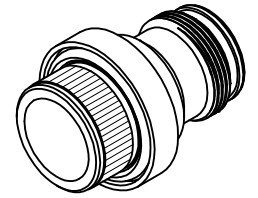

PART # 73162-6090

IEC 61169-54	INTERFACE
SPECIFICATION	DESCRIPTION

CHG: NEW RELEASE PDR NO: PDR1509750 EC NO: URF2016-0656 DRAWN: YHUANG11 2015/10/07 CHKD: MXU11 2015/10/07 APPR: MYE08 2016/04/15	QUALITY SYMBOLS ▽=0 ▽=0 ▽=0	GENERAL TOLERANCES (UNLESS SPECIFIED) mm INCH 4 PLACES ± --- ± --- 3 PLACES ± --- ± --- 2 PLACES ± --- ± --- 1 PLACE ± --- ± --- 0 PLACE ± --- ± --- ANGULAR ± 2°	DIMENSION STYLE MM/IN	SCALE DESIGN UNITS METRIC	THIRD ANGLE PROJECTION	DRAWN BY YHUANG11 DATE 2015/10/07	CHECKED BY MXU11 DATE 2015/10/07	APPROVED BY MYE08 DATE 2016/04/15	TITLE 4.3-10 JACK, 50 OHM PUSH FIT, STANDARD 10-111-XX	MATERIAL NO. 731626090	DOCUMENT NO. SD-73162-609	SHEET NO. 1 OF 1