



EVQ5850-J-00A

36V, Smart Diode Controller with Reverse Protection Evaluation Board, AEC-Q100 Qualified

DESCRIPTION

The EVQ5850-J-00A is an evaluation board designed to demonstrate the capabilities of the MPQ5850, a 36V, smart diode controller with reverse protection.

The MPQ5850 is a smart diode controller that can drive an external N-channel MOSFET to replace a Schottky diode for reverse input protection. The device's 20mV ultra-low dropout minimizes power loss and enables a low minimum input voltage (V_{IN}), which makes the MPQ5850 well-suited for cold-crank conditions in automotive applications. The 4 μ A shutdown current also makes the device ideal for battery-powered applications. The ultra-fast transient response meets stringent ISO16750 requirements.

The MPQ5850 integrates an internal boost to provide a boost voltage that turns on the external N-channel MOSFET, even at low input voltages. An open-drain, power good (PG) signal indicates when the external N-channel MOSFET is fully on.

The EVQ5850-J-00A is fully assembled and tested. The MPQ5850 is available in a TSOT23-8 (2mmx3mm) package.

ELECTRICAL SPECIFICATIONS

Parameter	Symbol	Value	Units
Input voltage	V_{IN}	3.3 to 36	V
Output current	I_{OUT}	5	A

FEATURES

- **Built to Handle Tough Automotive Transients:**
 - -36V Blocking Voltage
 - Load Dump Up to 42V
 - Cold Crank Down to 3V
 - Rectifies AC Frequency Up to 100kHz
 - Strong Gate Drive Ability: 170mA Pull-Up and 430mA Pull-Down
- **Extended Vehicle Battery Life:**
 - Low Quiescent Current in Standby Mode (4 μ A)
 - Low Quiescent Current in Steady State (30 μ A)
- **Reduced Board Size:**
 - Available in a TSOT23-8 (2mmx3mm) Package
- **Additional Features:**
 - 20mV Ultra-Low Dropout
 - Integrates a Boost Converter
 - Power Good (PG) Indication for RES Out of Regulation, Fast Pull-Up, and Part Disabling
 - Available in AEC-Q100 Grade 1

APPLICATIONS

- Automotive System Protection
- Automotive ADAS Systems (Cameras)
- Automotive Infotainment Systems, Including Digital Clusters and Head Units
- Battery-Powered Systems

All MPS parts are lead-free, halogen-free, and adhere to the RoHS directive. For MPS green status, please visit the MPS website under Quality Assurance. "MPS", the MPS logo, and "Simple, Easy Solutions" are trademarks of Monolithic Power Systems, Inc. or its subsidiaries.

EVQ5850-J-00A EVALUATION BOARD

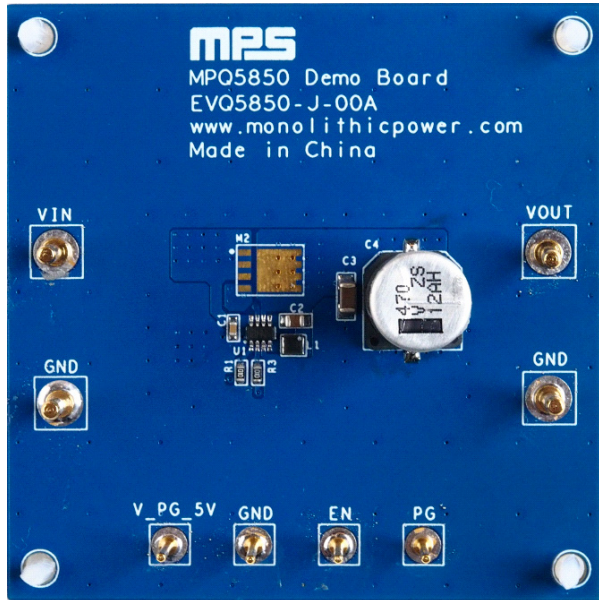

LxWxH (6.35cmx6.35cmx1.8cm)

Board Number	MPS IC Number
EVQ5850-J-00A	MPQ5850GJ-AEC1

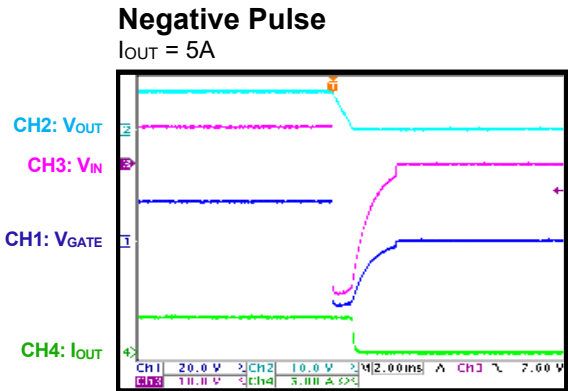

QUICK START GUIDE

1. Preset the power supply between 3.3V and 36V, then turn off the power supply. Electronic loads represent a negative impedance to the regulator, so set the load current between 0A and 5A.
2. Connect the power supply terminals to:
 - a. Positive (+): VIN
 - b. Negative (-): GND
3. Connect the load terminals to:
 - a. Positive (+): VOUT
 - b. Negative (-): GND
4. After making the connections, turn on the power supply.
5. To use the enable function, apply a digital input to the EN pin. Drive EN above 1.2V to turn the regulator on; drive EN below 1V to turn it off . If the enable function is not being used, connect EN directly to VIN.
6. To use the PG function, add a 5V external supply to V_PG_5V to drive the PG signal.

EVALUATION BOARD SCHEMATIC

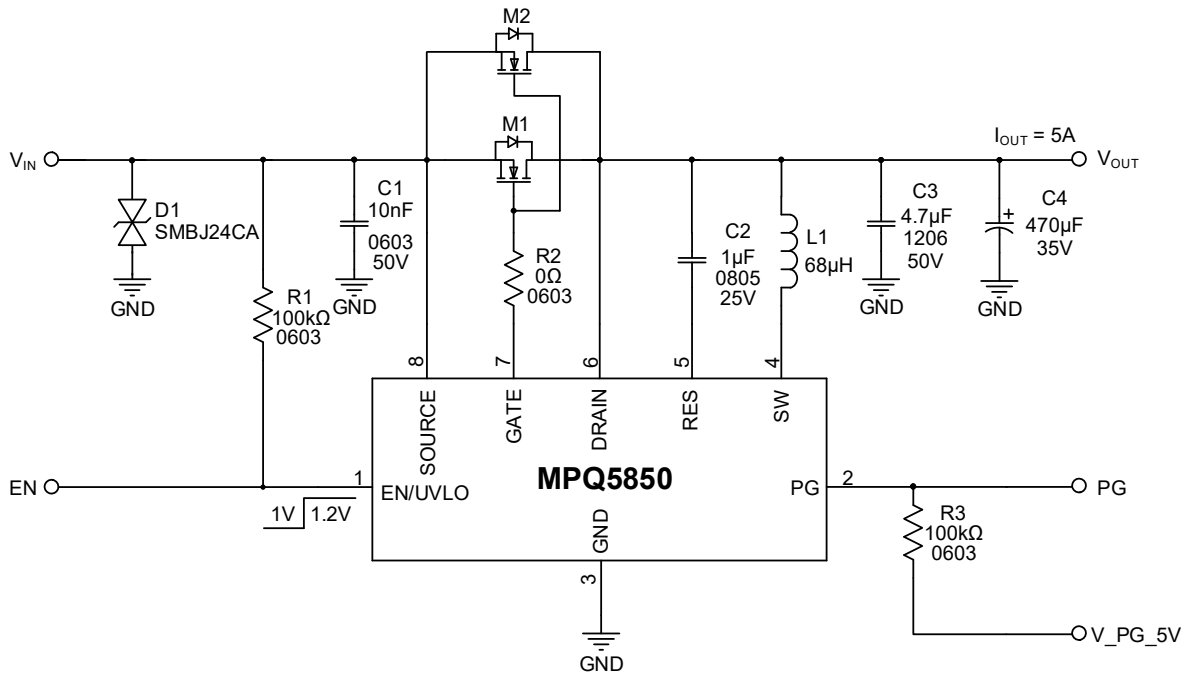

Figure 1: Evaluation Board Schematic

EVQ5850-J-00A BILL OF MATERIALS

Qty	Ref	Value	Description	Package	Manufacturer	Manufacturer PN
4	PG, EN, GND, V_PG_5V	1mm male	Connector	DIP	Any	
1	C1	10nF	Ceramic capacitor, 50V, X7R	0603	Murata	GRM188R71H103KA01D
1	C2	1 μ F	Ceramic capacitor, 25V, X7R	0805	Murata	GCM21BR71E105KA56L
1	C3	4.7 μ F	Ceramic capacitor, 50V, X7R	1206	Murata	GRM31CR71H475KA12L
1	C4	470 μ F	Electrolytic capacitor, 35V	SMD	Panasonic	EEHZS1V471P
1	D1	24V	TVS diode	DO- 214AA-2	Vishay	SMBJ24CA-E3/52
4	VOUT, VIN, GND, GND	2mm male	Connector	DIP	Any	
1	L1	68 μ H	Inductor, DCR = 6.14 Ω , I _{SAT} = 0.2A	SMD	Coilcraft	XPL2010-683MLB
1	M1	60V	N-channel MOSFET, 4.8m Ω , 83A	TO-252	Analog Power	AM90N06-04D-T1-PF
0	M2	NC				
2	R1, R3	100k Ω	Film resistor, 1%	0603	Yageo	RC0603FR-07100KL
1	R2	0 Ω	Film resistor, 1%	0603	Yageo	RC0603FR-070RL
1	U1	MPQ5850	Smart diode controller, 36V	TSOT23-8 (2mmx 3mm)	MPS	MPQ5850GJ-AEC1

EVB TEST RESULTS

Performance curves and waveforms are tested on the evaluation board. $V_{IN} = 12V$, $I_{OUT} = 5A$, $L = 68\mu H$, $T_A = 25^\circ C$, unless otherwise noted.

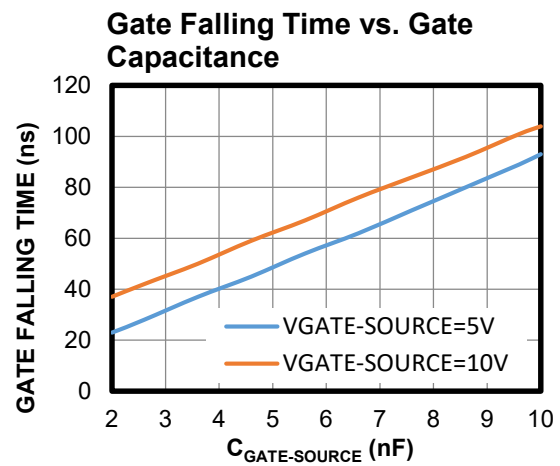
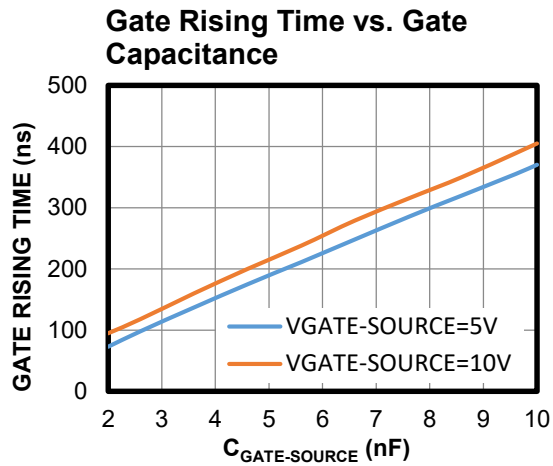

EVB TEST RESULTS (continued)

Performance curves and waveforms are tested on the evaluation board. $V_{IN} = 12V$, $I_{OUT} = 5A$, $L = 68\mu H$, $T_A = 25^\circ C$, unless otherwise noted.

CISPR25 Class 5 Peak Conducted Emissions

150kHz to 108MHz

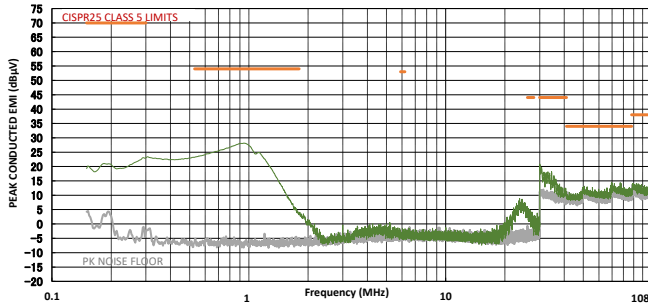

CISPR25 Class 5 Average Conducted Emissions

150kHz to 108MHz

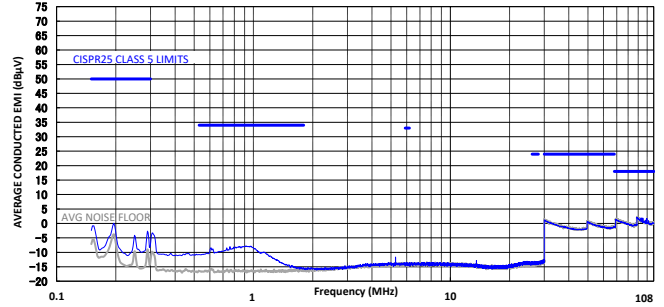

CISPR25 Class 5 Peak Radiated Emissions

150kHz to 30MHz

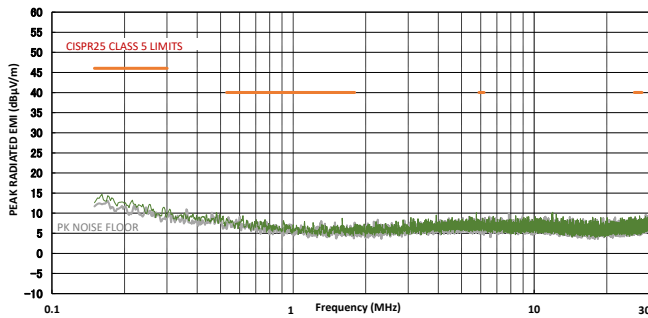

CISPR25 Class 5 Average Radiated Emissions

150kHz to 30MHz

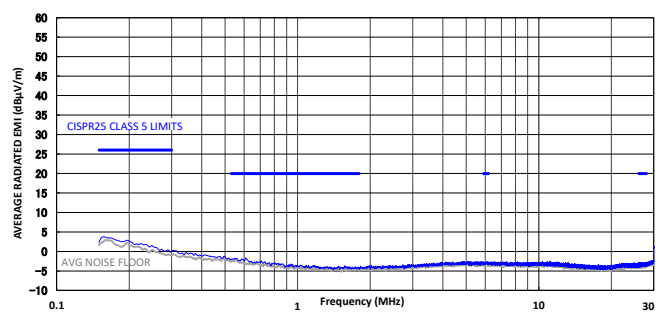

CISPR25 Class 5 Peak Radiated Emissions

Horizontal, 30MHz to 200MHz

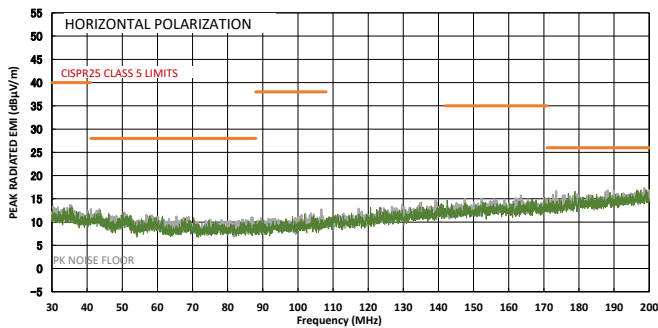

CISPR25 Class 5 Average Radiated Emissions

Horizontal, 30MHz to 200MHz

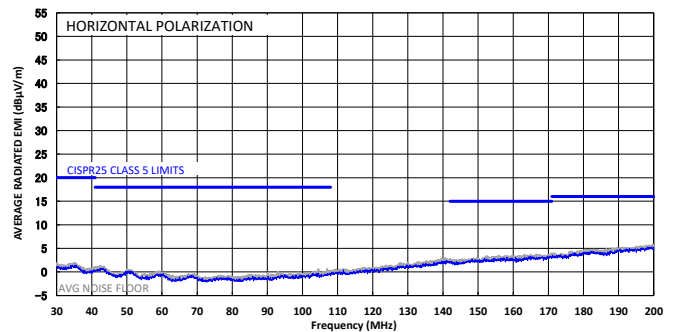

EVB TEST RESULTS (continued)

Performance curves and waveforms are tested on the evaluation board. $V_{IN} = 12V$, $I_{OUT} = 5A$, $L = 68\mu H$, $T_A = 25^\circ C$, unless otherwise noted.

CISPR25 Class 5 Peak Radiated Emissions

Vertical, 30MHz to 200MHz

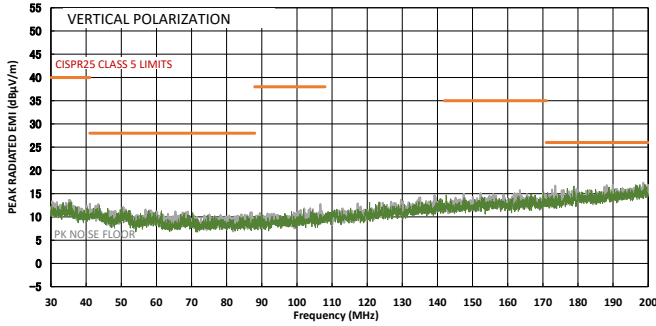

CISPR25 Class 5 Average Radiated Emissions

Vertical, 30MHz to 200MHz

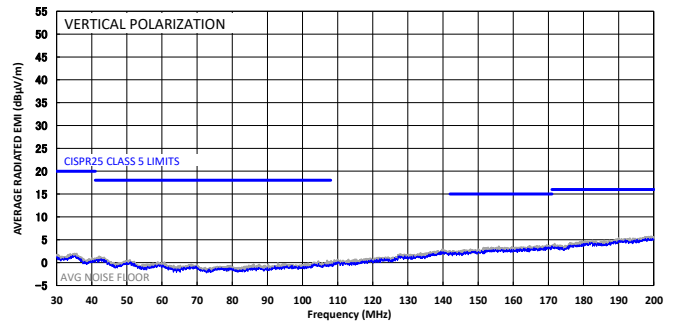

CISPR25 Class 5 Peak Radiated Emissions

Horizontal, 200MHz to 1GHz

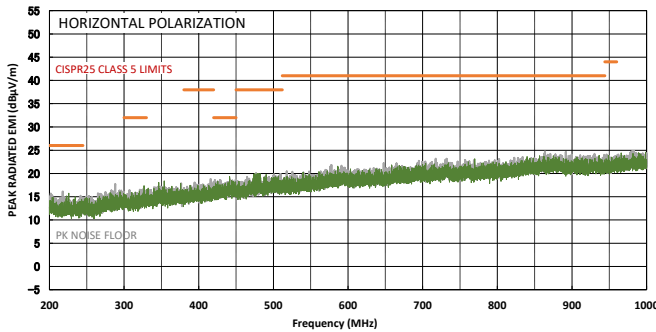

CISPR25 Class 5 Average Radiated Emissions

Horizontal, 200MHz to 1GHz

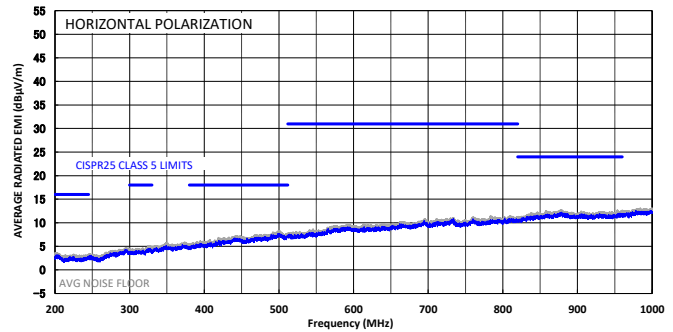

CISPR25 Class 5 Peak Radiated Emissions

Vertical, 200MHz to 1GHz

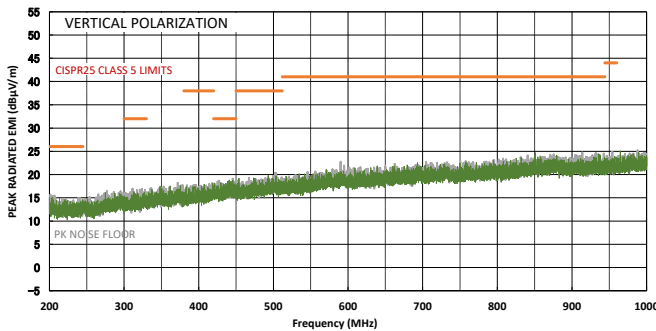

CISPR25 Class 5 Average Radiated Emissions

Vertical, 200MHz to 1GHz

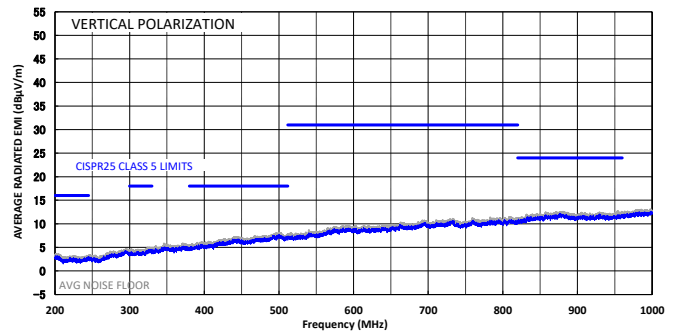

EVB TEST RESULTS (continued)

Performance curves and waveforms are tested on the evaluation board. $V_{IN} = 12V$, $I_{OUT} = 5A$, $L = 68\mu H$, $T_A = 25^\circ C$, unless otherwise noted.

Steady State (for Internal Boost)

$I_{OUT} = 0A$

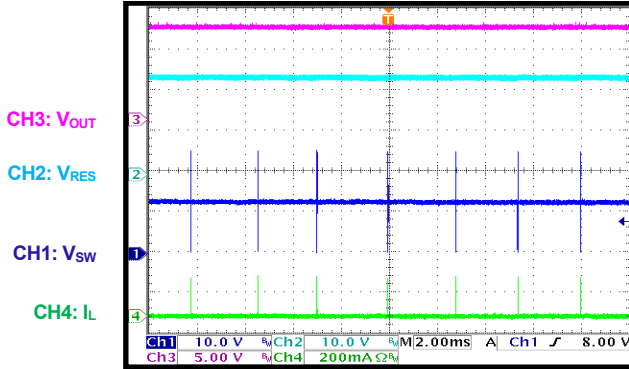

Steady State (for Smart Diode)

$I_{OUT} = 0A$

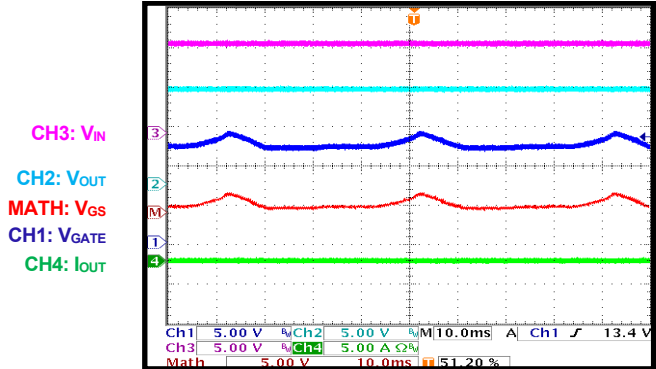

Steady State (for Internal Boost)

$I_{OUT} = 5A$

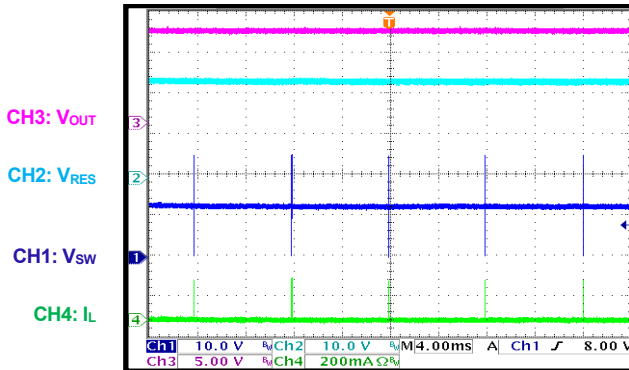

Steady State (for Smart Diode)

$I_{OUT} = 5A$

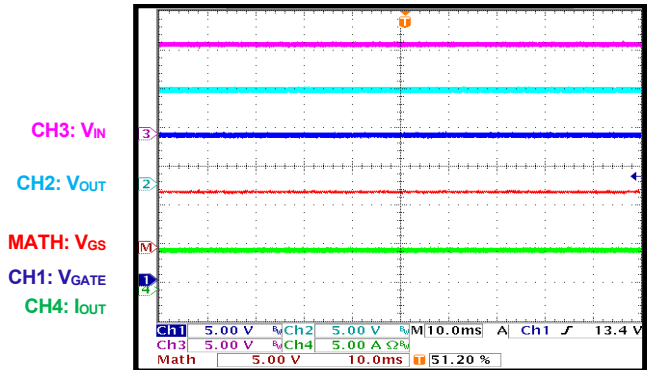

Start-Up through VIN (for Internal Boost)

$I_{OUT} = 0A$

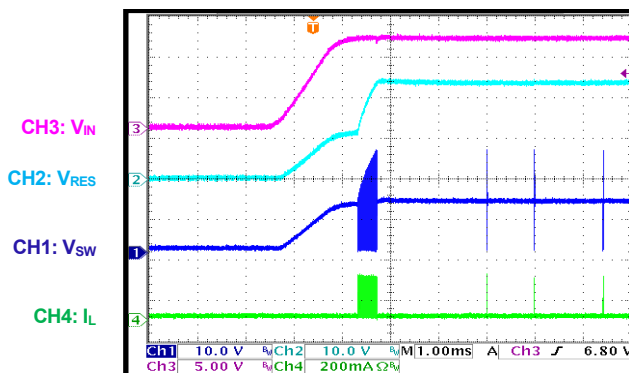

Start-Up through VIN (for Smart Diode)

$I_{OUT} = 0A$

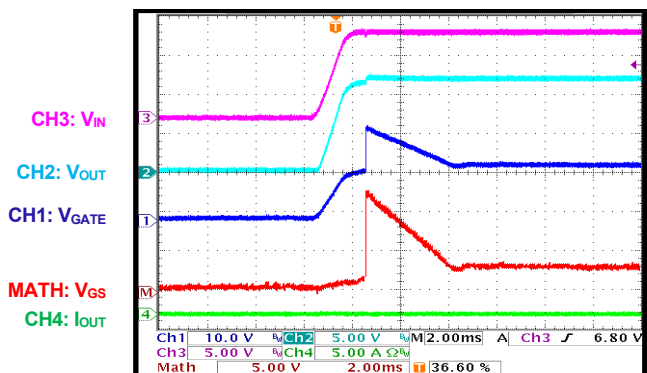

EVB TEST RESULTS (continued)

Performance curves and waveforms are tested on the evaluation board. $V_{IN} = 12V$, $I_{OUT} = 5A$, $L = 68\mu H$, $T_A = 25^\circ C$, unless otherwise noted.

Start-Up through VIN (for Internal Boost)

$I_{OUT} = 5A$

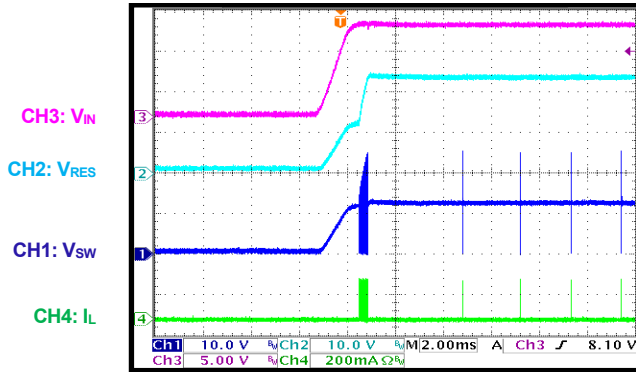

Start-Up through VIN (for Smart Diode)

$I_{OUT} = 5A$

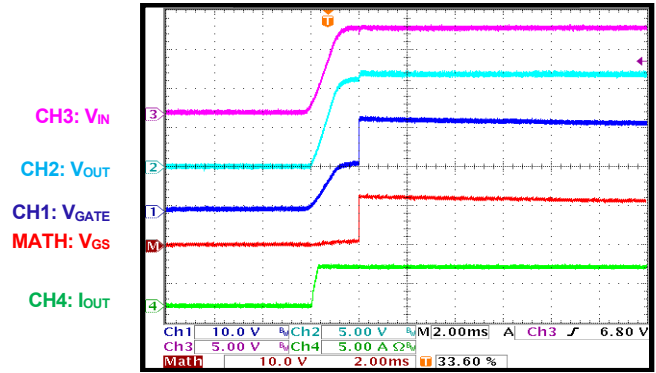

Shutdown through VIN (for Internal Boost)

$I_{OUT} = 0A$

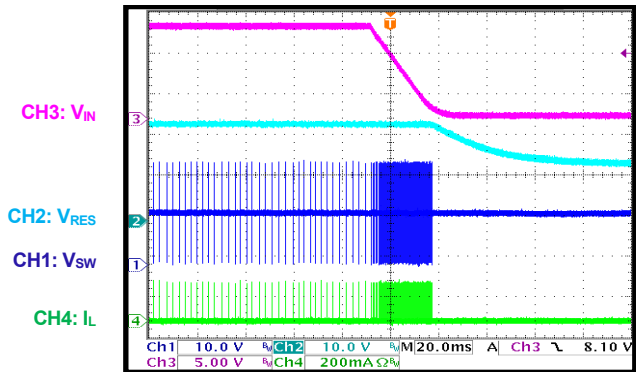

Shutdown through VIN (for Smart Diode)

$I_{OUT} = 0A$

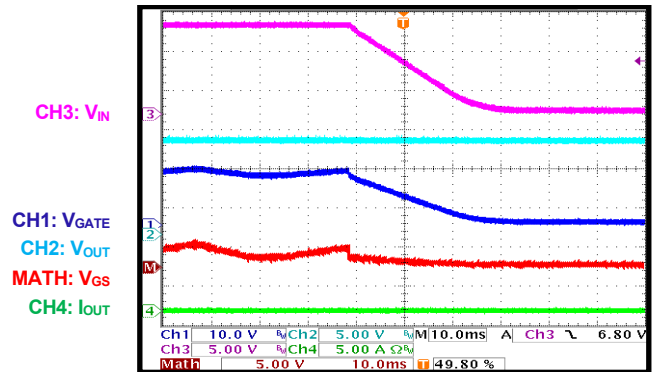

Shutdown through VIN (for Internal Boost)

$I_{OUT} = 5A$

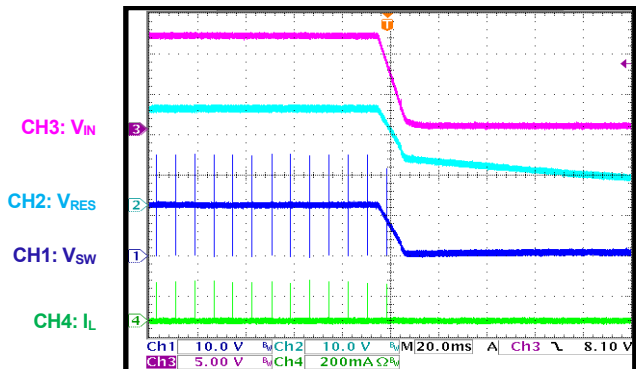

Shutdown through VIN (for Smart Diode)

$I_{OUT} = 5A$

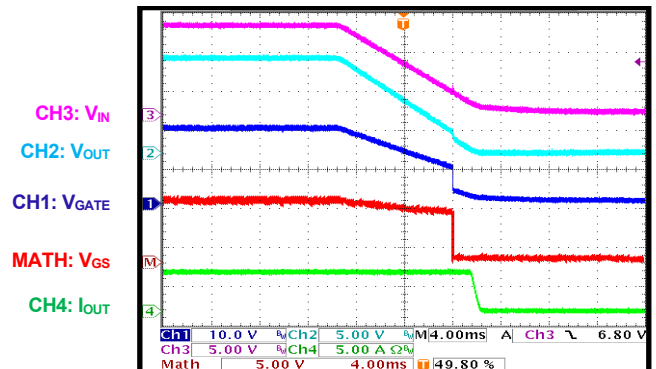

EVB TEST RESULTS (continued)

Performance curves and waveforms are tested on the evaluation board. $V_{IN} = 12V$, $I_{OUT} = 5A$, $L = 68\mu H$, $T_A = 25^\circ C$, unless otherwise noted.

Start-Up through EN (for Internal Boost)

$I_{OUT} = 0A$

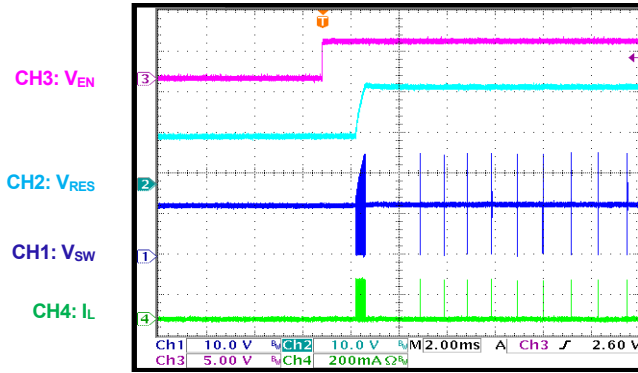

Start-Up through EN (for Smart Diode)

$I_{OUT} = 0A$

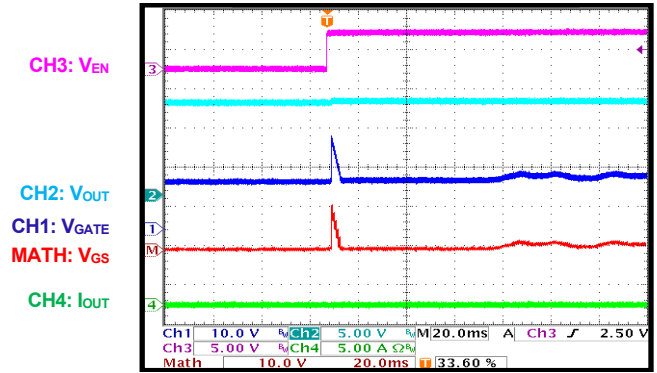

Start-Up through EN (for Internal Boost)

$I_{OUT} = 5A$

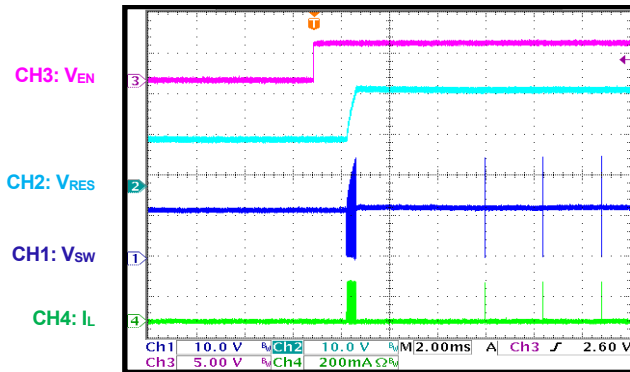

Start-Up through EN (for Smart Diode)

$I_{OUT} = 5A$

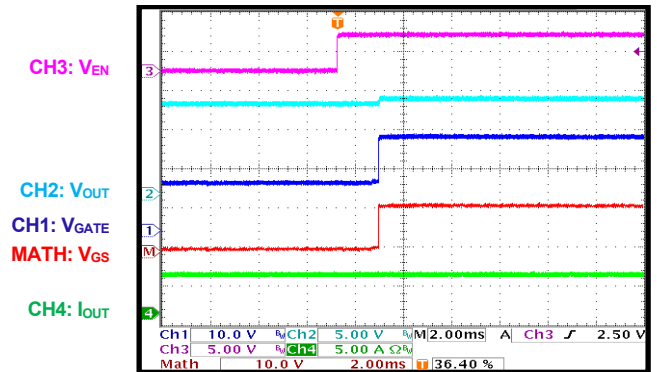

Shutdown through EN (for Internal Boost)

$I_{OUT} = 0A$

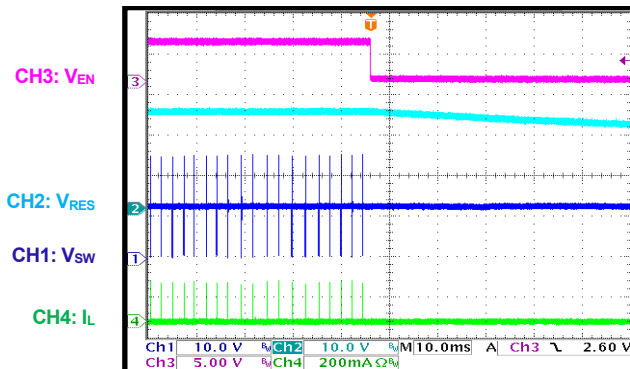

Shutdown through EN (for Smart Diode)

$I_{OUT} = 0A$

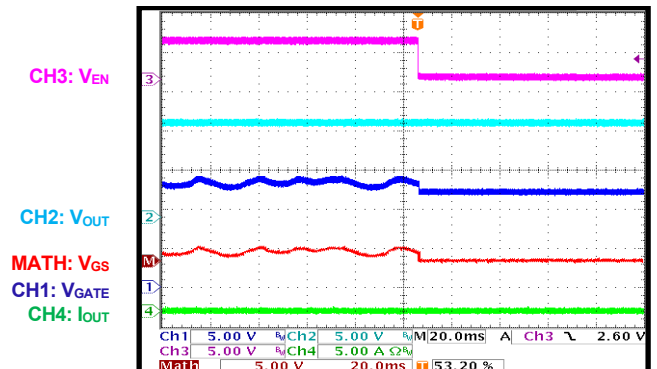

EVB TEST RESULTS (continued)

Performance curves and waveforms are tested on the evaluation board. $V_{IN} = 12V$, $I_{OUT} = 5A$, $L = 68\mu H$, $T_A = 25^\circ C$, unless otherwise noted.

Shutdown through EN (for Internal Boost)

$I_{OUT} = 5A$

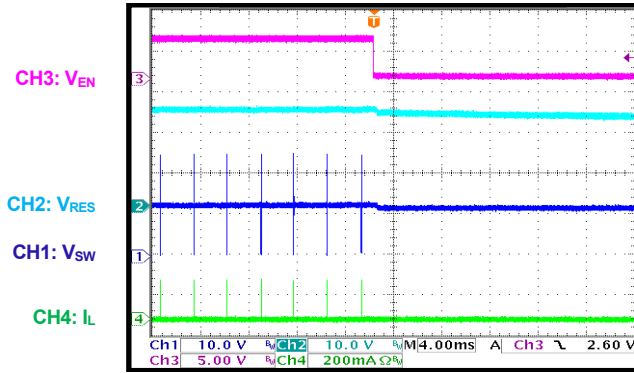

Shutdown through EN (for Smart Diode)

$I_{OUT} = 5A$

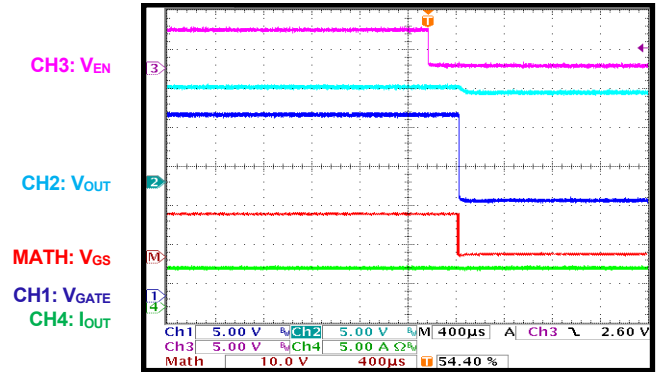

Load Transient

$I_{OUT} = 0A$ to $5A$, $6A/\mu s$

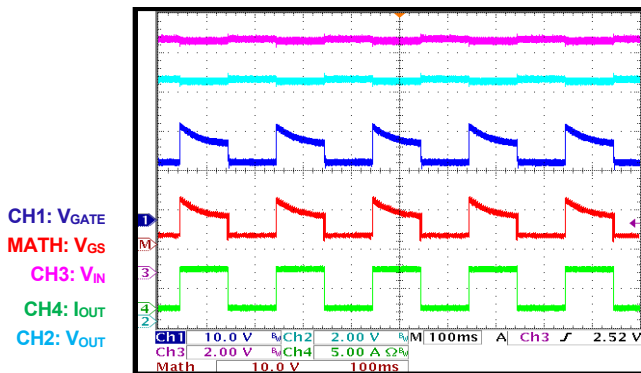

PG in Start-Up Through VIN

$I_{OUT} = 0A$

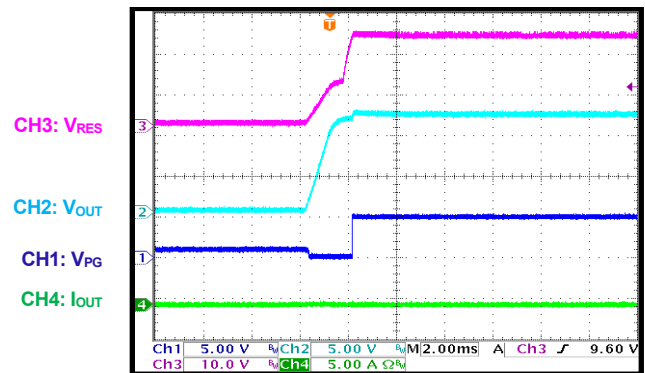

PG in Start-Up through VIN

$I_{OUT} = 5A$

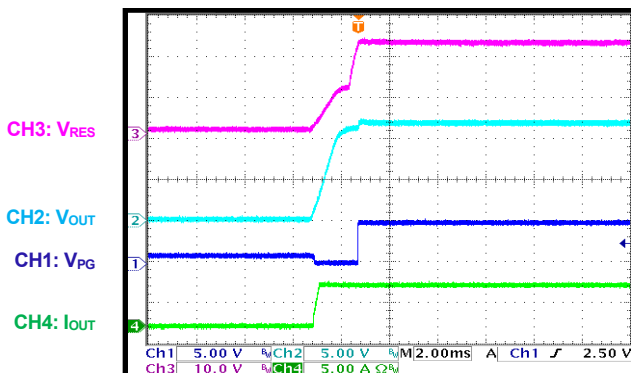

PG in Shutdown through VIN

$I_{OUT} = 0A$

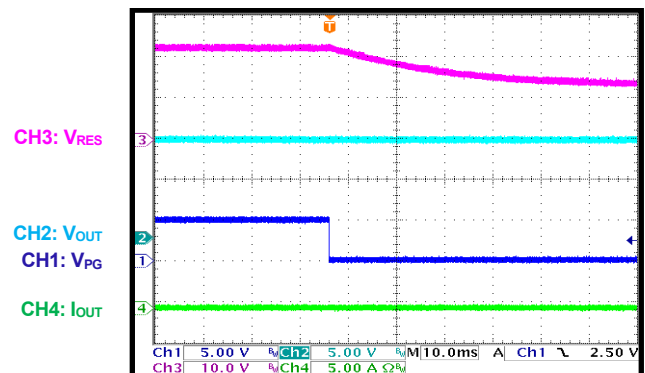

EVB TEST RESULTS (continued)

Performance curves and waveforms are tested on the evaluation board. $V_{IN} = 12V$, $I_{OUT} = 5A$, $L = 68\mu H$, $T_A = 25^\circ C$, unless otherwise noted.

PG in Shutdown through VIN

$I_{OUT} = 5A$

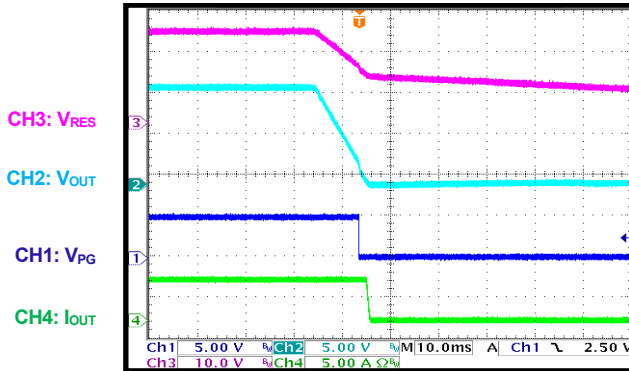

PG in Start-Up through EN

$I_{OUT} = 0A$

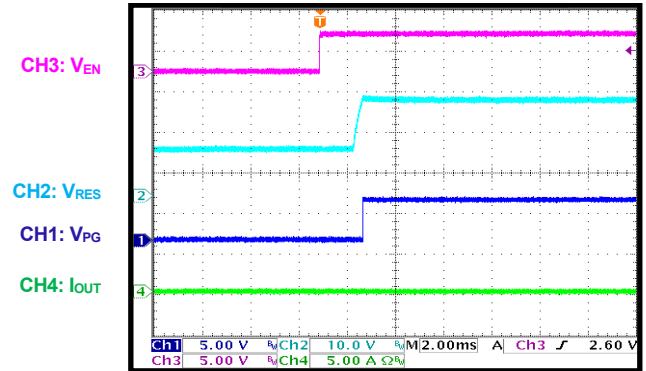

PG in Start-Up through EN

$I_{OUT} = 5A$

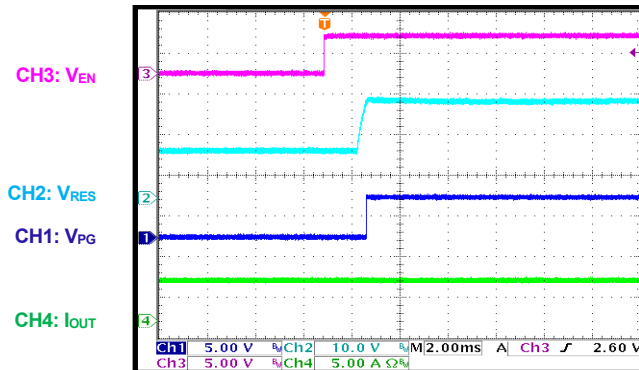

PG in Shutdown through EN

$I_{OUT} = 0A$

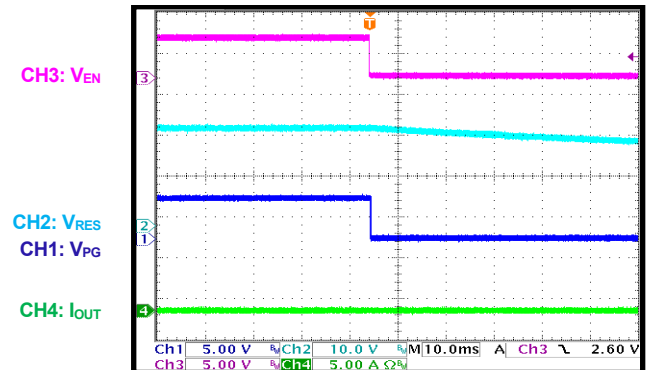

PG in Shutdown through EN

$I_{OUT} = 5A$

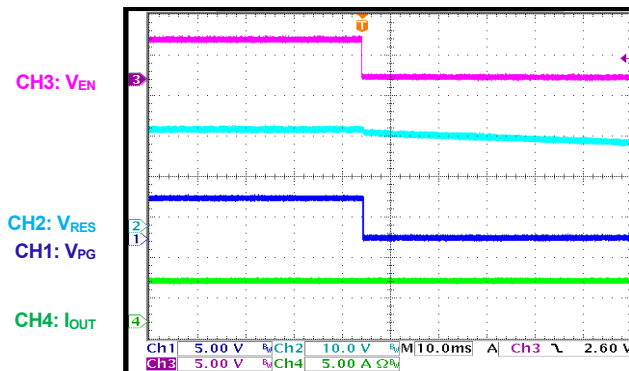

Negative Pulse

$I_{OUT} = 0A$

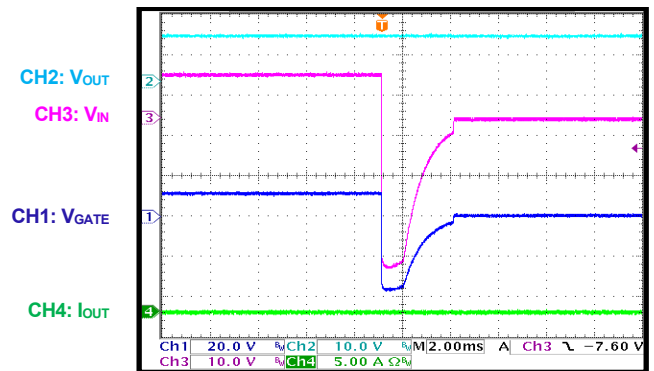

EVB TEST RESULTS (continued)

Performance curves and waveforms are tested on the evaluation board. $V_{IN} = 12V$, $I_{OUT} = 5A$, $L = 68\mu H$, $T_A = 25^\circ C$, unless otherwise noted.

Negative Pulse

$I_{OUT} = 5A$

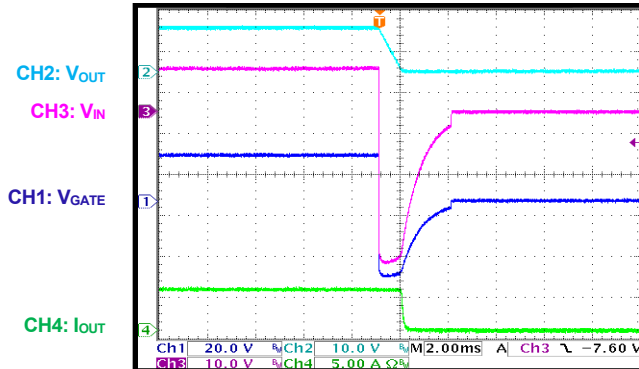

Load Dump

$I_{OUT} = 5A$

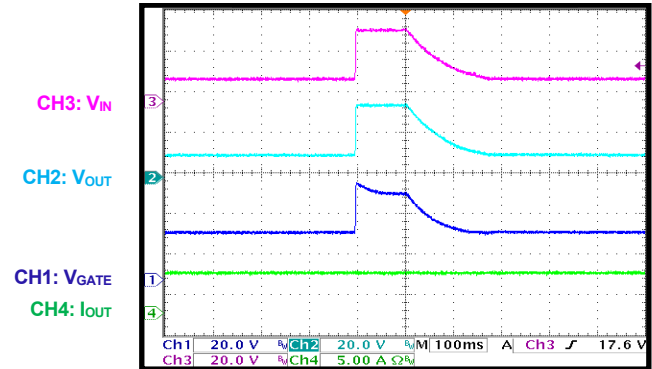

Cold Crank

$I_{OUT} = 5A$

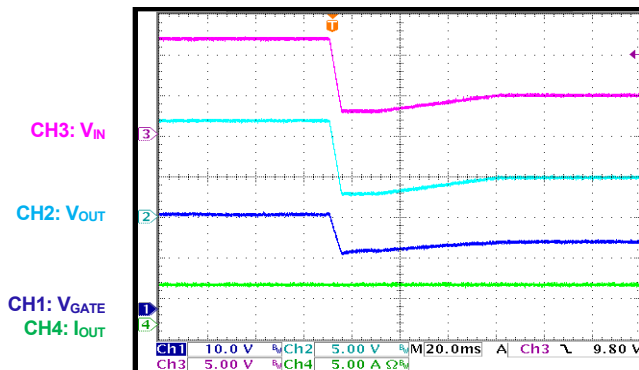

Start Pulses

$I_{OUT} = 5A$

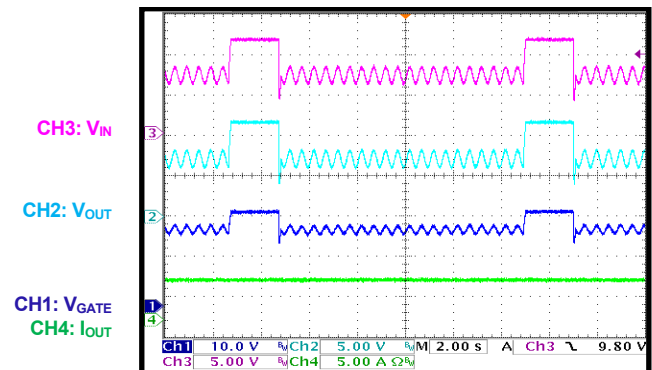

Slow Decrease and Increase of the Supply Voltage

$I_{OUT} = 0A$

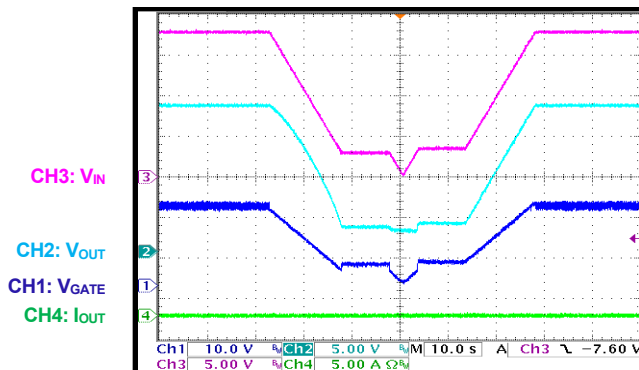

Slow Decrease and Increase of the Supply Voltage

$I_{OUT} = 5A$

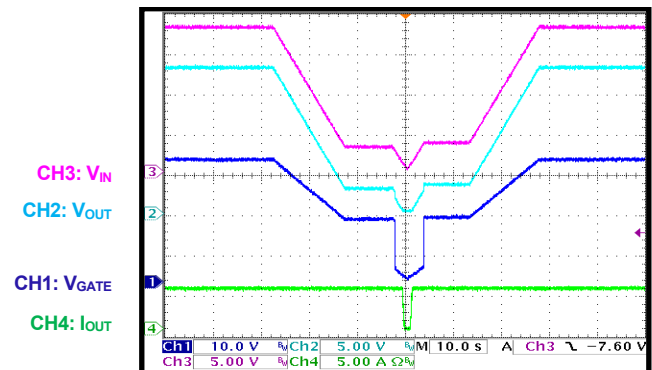

EVb TEST RESULTS (continued)

Performance curves and waveforms are tested on the evaluation board. $V_{IN} = 12V$, $I_{OUT} = 5A$, $L = 68\mu H$, $T_A = 25^\circ C$, unless otherwise noted.

Slow Decrease and Quick Increase of the Supply Voltage

$I_{OUT} = 0A$

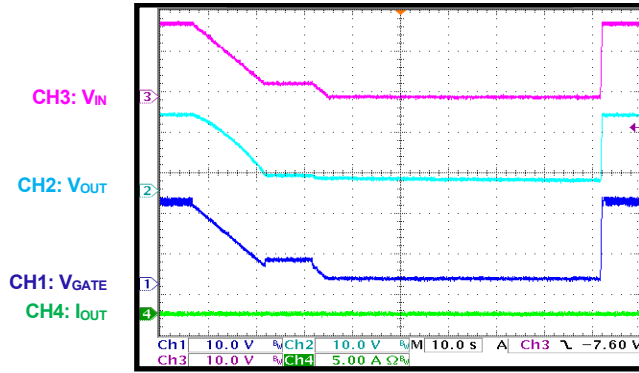

Slow Decrease and Quick Increase of the Supply Voltage

$I_{OUT} = 5A$

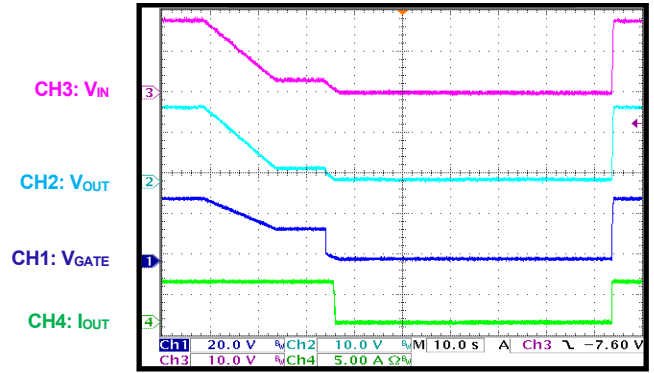

Simultaneous Input

$V_{PP} = 6V$, $f = 15Hz$, $I_{OUT} = 0A$

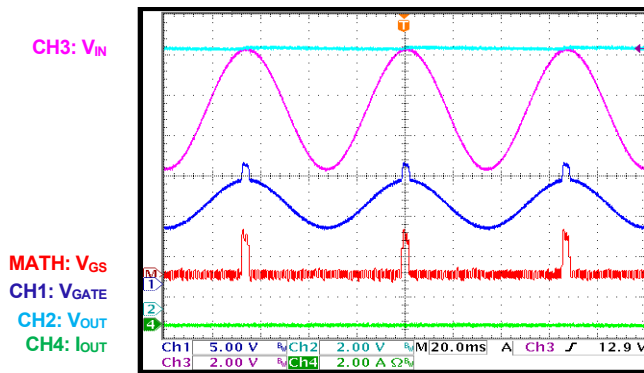

Simultaneous Input

$V_{PP} = 6V$, $f = 15Hz$, $I_{OUT} = 3A$

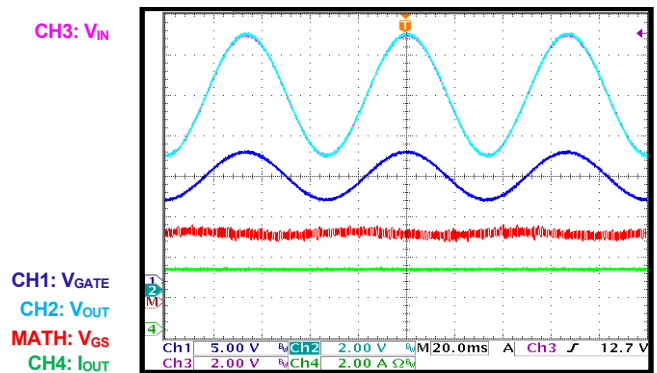

Simultaneous Input

$V_{PP} = 6V$, $f = 1kHz$, $I_{OUT} = 0A$

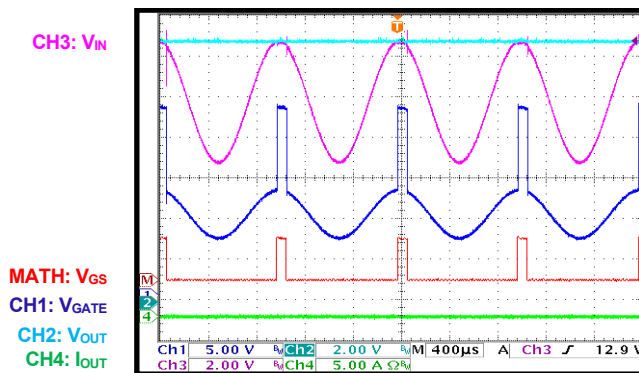

Simultaneous Input

$V_{PP} = 6V$, $f = 1kHz$, $I_{OUT} = 3A$

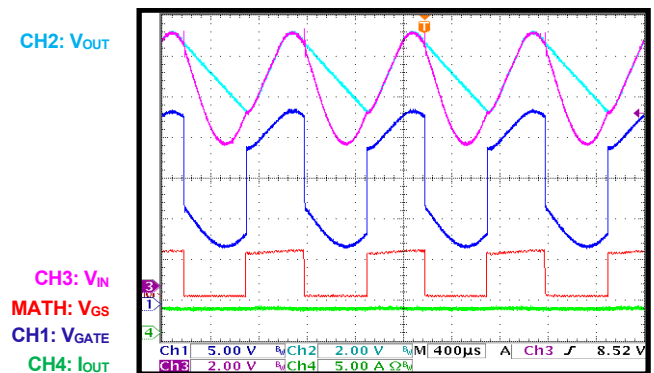

PCB LAYOUT

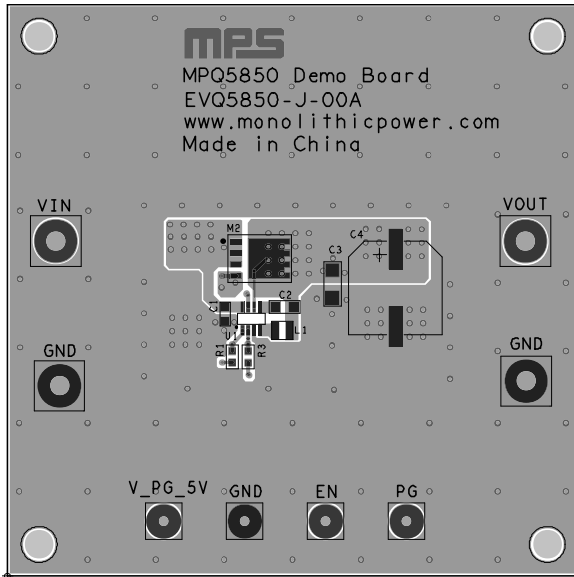

Figure 2: Top Silk and Top Layer

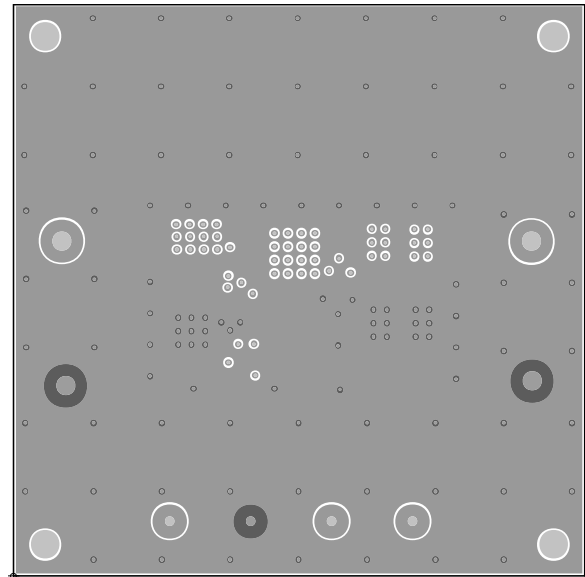

Figure 3: Mid-Layer 1

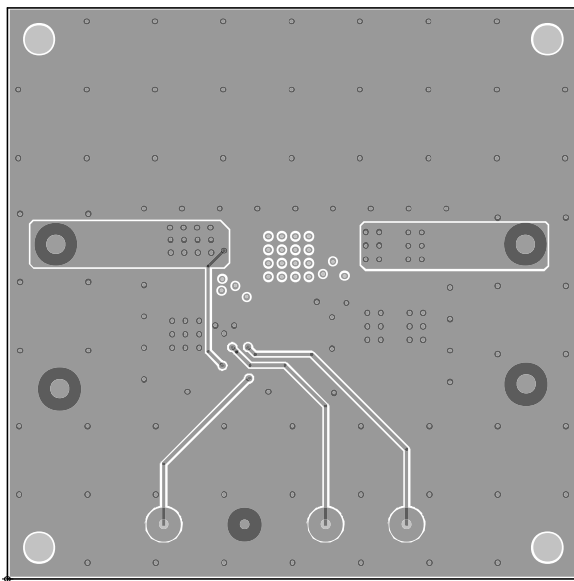

Figure 4: Mid-Layer 2

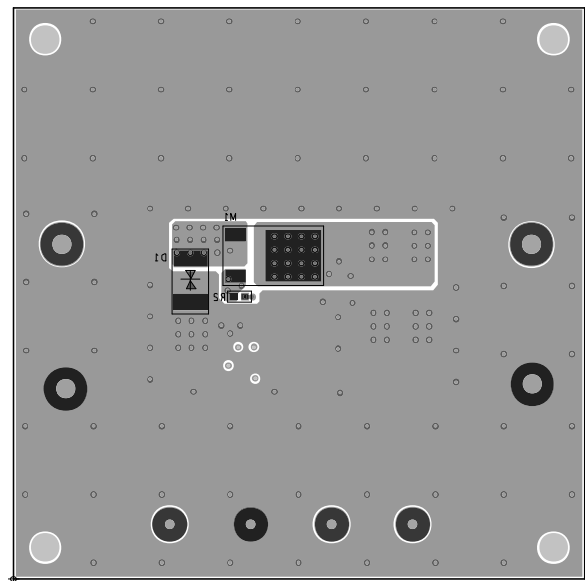

Figure 5: Bottom Layer and Bottom Silk

REVISION HISTORY

Revision #	Revision Date	Description	Pages Updated
1.0	10/27/2021	Initial Release	-

Notice: The information in this document is subject to change without notice. Please contact MPS for current specifications. Users should warrant and guarantee that third-party Intellectual Property rights are not infringed upon when integrating MPS products into any application. MPS will not assume any legal responsibility for any said applications.