

DUAL SYNCHRONOUS PWM CONTROLLER WITH CURRENT SHARING CIRCUITRY AND AUTO-RESTART

FEATURES

- Dual Synchronous Controller with 180° out-of-phase
- Configurable to 2-Independent Outputs or 2-Phase Single Output
- Current Sharing Using Inductor's DCR
- Current Limit using MOSFET's $R_{DS(ON)}$
- Hiccup/Latched Current Limit
- Latched Over-Voltage Protection
- Vcc from 4.5V to 16V Input
- Programmable Switching Frequency up to 500KHz
- Two Independent Soft-Starts/ Shutdowns
- 0.8V Precision Reference Voltage Available
- Power Good Output
- External Frequency Synchronization

APPLICATIONS

- Embedded Computer Systems
- Telecom Systems
- Point of Load Power Architectures

DESCRIPTION

The IRU3146 IC combines a Dual synchronous Buck controller, providing a cost-effective, high performance and flexible solution. The IRU3146 can be configured as 2-independent or as 2-phase controller. The 2-phase configuration is ideal for high current applications. The IRU3146 features 180° out of phase operation which reduces the required input/output capacitance and results in a few number of capacitor quantity. Other key features offered by this device include two independent programmable soft starts, programmable switching frequency up to 500KHz per phase, under voltage lockout function. The current limit is provided by sensing the lower MOSFET's on-resistance for optimum cost and performance.

- 2-Phase Power Supply
- Graphic Card
- DDR Memory Applications

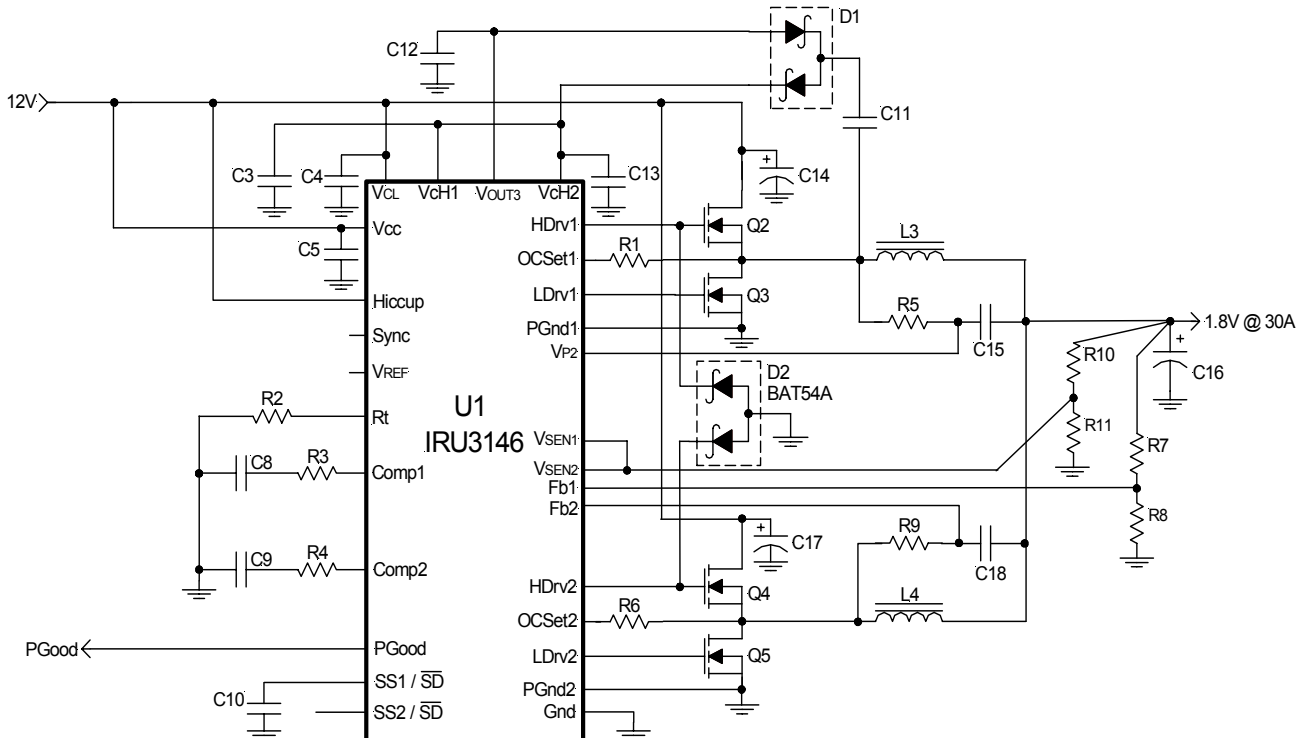

Figure 1 - Typical application of IRU3146 in 2-phase configuration with inductor current sensing

PACKAGE ORDER INFORMATION

DEVICE	PACKAGE
IRU3146CF	28-Pin TSSOP (F)

ABSOLUTE MAXIMUM RATINGS

V_{CC}, V_{CL} Supply Voltage -0.5V To 16V
 V_{CH1} and V_{CH2} Supply Voltage -0.5V To 25V
 PGOOD..... -0.5V To 16V
 Storage Temperature Range -40°C To 125°C
 Operating Junction Temperature Range -40°C To 125°C

Caution: Stresses above those listed in Absolute Maximum Ratings* may cause permanent damage to the device.

PACKAGE INFORMATION

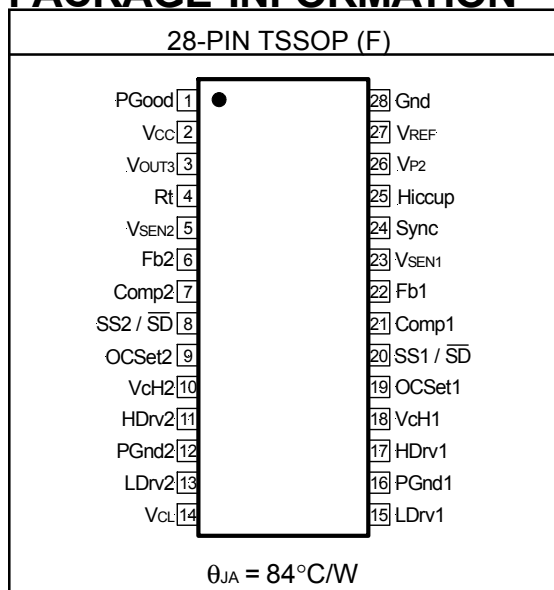

ELECTRICAL SPECIFICATIONS

Unless otherwise specified, these specifications apply over V_{CC}=12V, V_{CH1}=V_{CH2}=V_{CL}=12V and T_A=0 to 70°C. Typical values refer to T_A=25°C. Low duty cycle pulse testing is used which keeps junction and case temperatures equal to the ambient temperature.

PARAMETER	SYM	TEST CONDITION	MIN	TYP	MAX	UNITS
Reference Voltage Section						
Reference Voltage	V _{REF}		0.789	0.805	0.821	V
Voltage Line Regulation	L _{REG}	5<V _{CC} <12		0.02	0.04	%/V
UVLO Section						
UVLO Threshold - V _{CC}	UVLO _{VCC}	Supply Ramping Up	3.9	4.2	4.5	V
UVLO Hysteresis - V _{CC}		Ramp Up and Ramp Down		0.25		V
UVLO Threshold - V _{CH1}	UVLO _{VCH1}	Supply Ramping Up	3.2	3.5	3.8	V
UVLO Hysteresis - V _{CH1}		Ramp Up and Ramp Down		0.1		V
UVLO Threshold - V _{CH2}	UVLO _{VCH2}	Supply Ramping Up	3.2	3.5	3.8	V
UVLO Hysteresis - V _{CH2}		Ramp Up and Ramp Down		0.1		V
Supply Current Section						
V _{CC} Dynamic Supply Current	Dyn I _{CC}	Freq=300KHz, C _L =1500pF		10	15	mA
V _{CH1} & V _{CH2} Dynamic Current	Dyn I _{CH}	Freq=300KHz, C _L =1500pF		15	25	mA
V _{CL} Dynamic Supply Current	Dyn I _{CL}	Freq=300KHz, C _L =1500pF		15	25	mA
V _{CC} Static Supply Current	I _{CCQ}	SS=0V		10	15	mA
V _{CH1} /V _{CH2} Static Current	I _{CHQ}	SS=0V		6	10	mA
V _{CL} Static Supply Current	I _{CLQ}	SS=0V		6	10	mA

PARAMETER	SYM	TEST CONDITION	MIN	TYP	MAX	UNITS
Soft-Start Section						
Charge Current	SS _{IB}	SS=0V	20	25	32	μA
Power Good Section						
V _{SENS1} Lower Trip Point	PG _{FB1L}	V _{SENS1} Ramping Down	0.8V _{REF}	0.9V _{REF}	0.95V _{REF}	V
V _{SENS2} Lower Trip Point	PG _{FB2H}	V _{SENS2} Ramping Down	0.8V _{REF}	0.9V _{REF}	0.95V _{REF}	V
PGood Output Low Voltage		I _{SINK} =2mA		0.1	0.5	V
Error Amp Section						
Fb Voltage Input Bias Current	I _{FB1}	SS=3V		-0.1	-0.5	μA
Transconductance 1	g _{m1}		1400		2300	μmho
Transconductance 2	g _{m2}		1400		2300	μmho
Error Amp Source/Sink Current			60	100	140	μA
Input Offset Voltage for PWM1/2	V _{OS(ERR)2}	Fb to V _{REF}	-5	0	+5	mV
VP2 Voltage Range	VP2	Note1	0.8		1.5	V
Oscillator Section						
Frequency	Freq	R _{t(SET)} to 30K	255		345	KHz
Ramp Amplitude	V _{RAMP}	Note1		1.25		V
Synch Frequency Range		20% above free running freq			800	KHz
Synch Pulse Duration		Note1	200	300		ns
Synch High Level Threshold		Note1	2			V
Synch Low Level Threshold					0.8	V
V_{OUT3} Internal Regulator						
Output Voltage			5.9	6.2	6.7	V
Output Current			50			mA
Protection Section						
OVP Trip Threshold	OVP		1.1V _{REF}	1.15V _{REF}	1.2V _{REF}	V
OVP Fault Prop Delay		Output forced to 1.125V _{REF} , Note1			5	μs
Current Limit Threshold	OCSet		16	20	24	μA
Current Source		Hiccup pin pulled high, Note1				
Hiccup Duty Cycle				5		%
Hiccup High Level Threshold		Note1	2			V
Hiccup Low Level Threshold					0.8	V
Output Drivers Section						
Rise Time	T _r	C _L =1500pF, Figure 2		18	50	ns
Fall Time	T _f	C _L =1500pF, Figure 2		25	50	ns
Dead Band Time	T _{DB}	Figure 2		50	100	ns
Max Duty Cycle	D _{MAX}	Fb=0.6V, F _{SW} =300KHz		85		%
Min Duty Cycle	D _{MIN}	Fb=1V		0		%
Min Pulse Width	Puls(min)	F _{SW} =300KHz, Note1	150			ns
Thermal Shutdown Trip Point		Note 1		140		°C
Thermal Shutdown Hysteresis				20		°C

Note 1: Guaranteed by design but not tested for production.

DEADBAND TIME

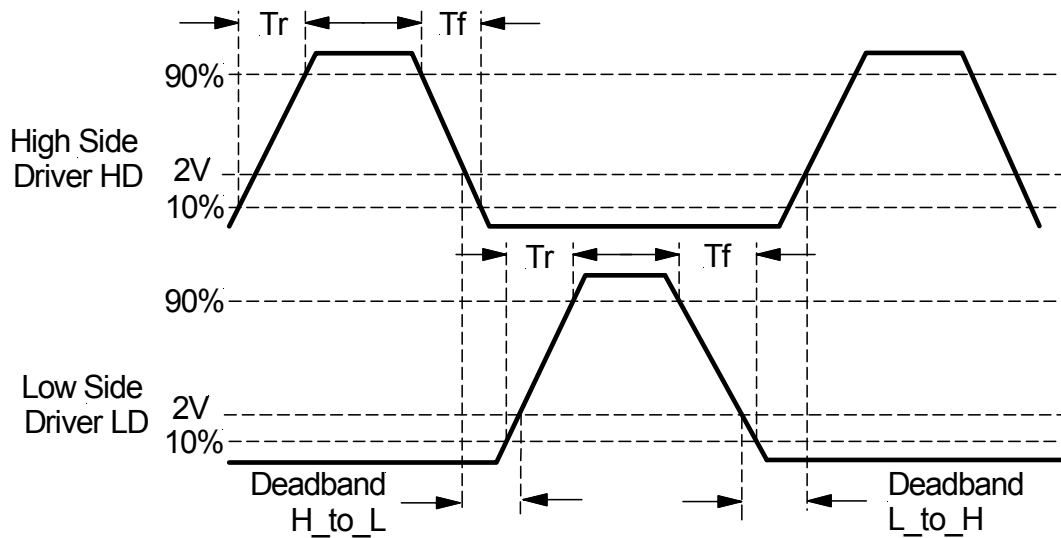

Figure 2 - Deadband time definition.

$$T_{DB(TYP)} = (\text{Deadband H_to_L} + \text{Deadband L_to_H}) / 2$$

PIN DESCRIPTIONS

PIN#	PIN SYMBOL	PIN DESCRIPTION
1	PGood	Power Good pin. Low when any of the outputs fall 10% below the set voltages.
2	VCC	Supply voltage for the internal blocks of the IC.
3	VOUT3	Output of the internal LDO.
4	Rt	Switching frequency setting resistor. (see Figure 10 for selecting resistor values).
5,23	VSEN2, VSEN1	Sense pins for OVP and PGood. For 2-Phase operation tie these pins together.
6,22	Fb2, Fb1	Inverting inputs to the error amplifiers. In current sharing mode, Fb1 is connected to a resistor divider to set the output voltage and Fb2 is connected to programming resistor to achieve current sharing. In independent 2-channel mode, these pins work as feedback inputs for each channel.
7,21	Comp2, Comp1	Compensation pins for the error amplifiers.
8 20	SS2 / $\overline{\text{SD}}$ SS1 / SD	These pins provide soft-start for the switching regulator. An internal current source charges external capacitors that are connected from these pins to ground which ramp up the output of the switching regulators, preventing them from overshooting as well as limiting the input current. The converter can be shutdown by pulling these pins below 0.3V.
9,19	OCSet2, OCSet1	Current limit resistor (RLIM) connection pins for output 1 and 2. The other ends of RLIMS are connected to the corresponding switching nodes.
10,18	VcH2, VcH1	Supply voltage for the high side output drivers. These are connected to voltages that must be typically 6V higher than their bus voltages. A 1µF high frequency capacitor must be connected from these pins to GND to provide peak drive current capability.
11,17	HDrv2, HDrv1	Output drivers for the high side power MOSFETs. 1)
12,16	PGnd2, PGnd1	These pins serve as the separate grounds for MOSFET drivers and should be connected to the system's ground plane.
13,15	LDrv2, LDrv1	Output drivers for the synchronous power MOSFETs.
14	VCL	Supply voltage for the low side output drivers. This pin should be high for normal operation
24	Sync	The internal oscillator may be synchronized to an external clock via this pin.
25	Hiccup	When pulled High, it puts the device current limit into a hiccup mode. When pulled Low, the output latches off, after an overcurrent event.

PIN DESCRIPTIONS

PIN#	PIN SYMBOL	PIN DESCRIPTION
26	VP2	Non-inverting input to the second error amplifier. In the current sharing mode, it is connected to the programming resistor. In independent 2-channel mode it is connected to VREF pin when Fb2 is connected to the resistor divider to set the output voltage.
27	VREF	Reference Voltage. The drive capability of this pin is about 2uA.
28	Gnd	Analog ground for internal reference and control circuitry. Connect to PGnd plane with a short trace.

1) These pins should not go negative (-0.5V), this may cause instability for the gate drive circuits. To prevent this, a low forward voltage drop diode is required between these pins and ground as shown in Figure 1.

BLOCK DIAGRAM

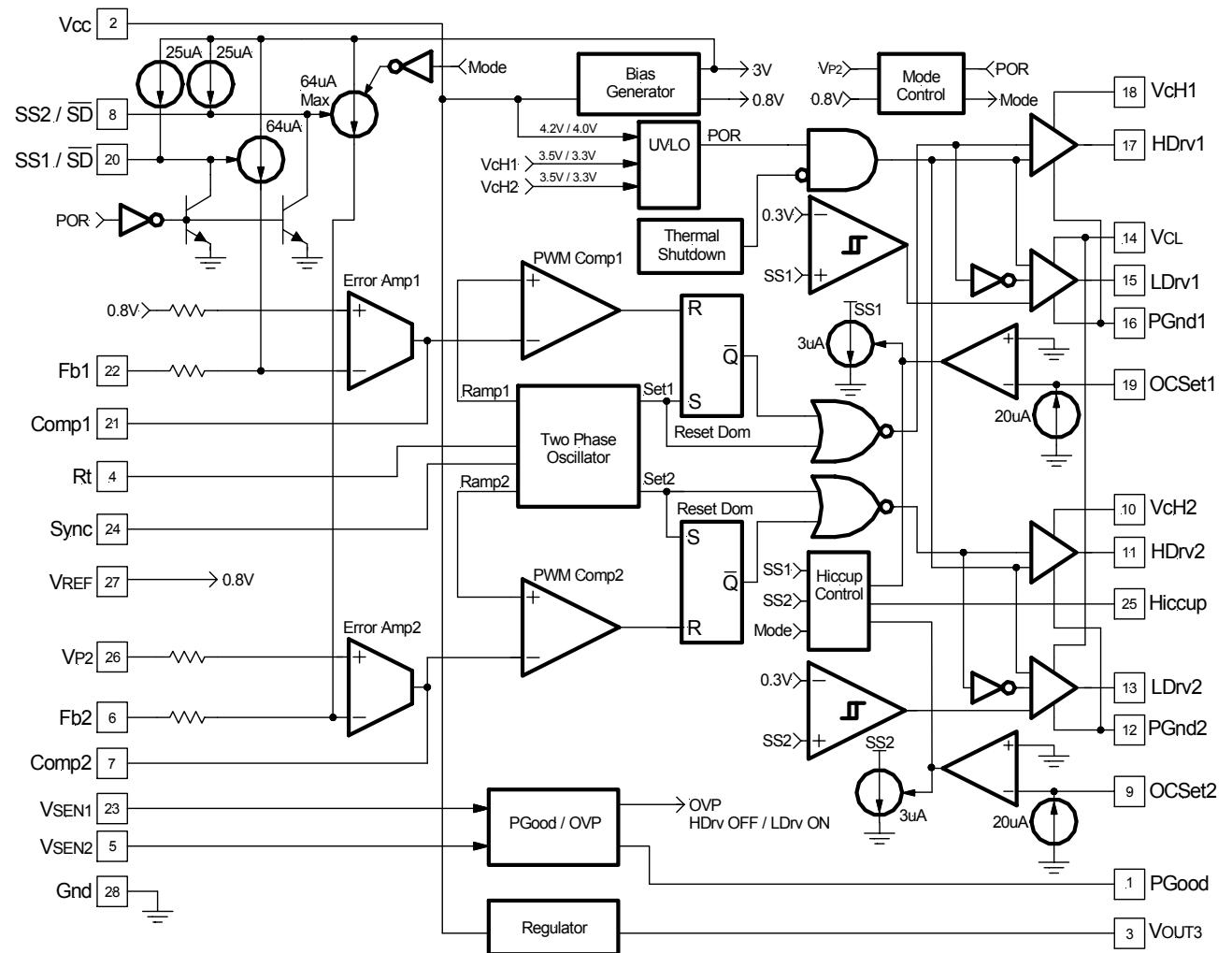

Figure 3 - Block diagram of IRU3146.

FUNCTIONAL DESCRIPTION

Introduction

The IRU3146 is versatile device for high performance Buck converters. It is included of two synchronous Buck controllers which can be operated both in two independent mode or in 2-phase mode.

The timing of the IC is provided through an internal oscillator circuit. These are two out-of-phase oscillators that can be programmed up to 400KHz per phase.

Supply Voltage

V_{cc} is the supply voltage for internal controller. The operating range is from 4.5V to 16V. It also is fed to the internal LDO. When V_{cc} is below under-voltage threshold, all MOSFET drivers will be turned off.

Internal Regulator

The regulator powers directly from V_{CC} and generates a regulated voltage (Typ. 6.2V@50mA). The output is protected for short circuit. This voltage can be used for charge pump circuitry as describe in Figure12.

Input Supplies UnderVoltage LockOut

The IRU3146 UVLO block monitors three input voltages (V_{CC}, V_{CH1} and V_{CH2}) to ensure reliable start up. The MOSFET driver output turn off when any of the supply voltages drops below set thresholds. Normal operation resumes once the supply voltages rise above the set values.

Independent Mode

In this mode the IRU3146 provides control to two independent output power supplies with either common or different input voltages. The output voltage of each individual channel is set and controlled by the output of the error amplifier, which is the amplified error signal from the sensed output voltage and the reference voltage. The error amplifier output voltage is compared to the ramp signal thus generating fixed frequency pulses of variable duty-cycle, which are applied to the FET drivers, Figure18 shows a typical schematic for such application.

2-Phase Mode

This feature allows to connect both outputs together to increase current handling capability of the converter to support a common load. The current sharing can be done either using external resistors or sensing the DCR of inductors (see Figure 4). In this mode, one control loop acts as a master and sets the output voltage as a regular Voltage Mode Buck controller and the other control loop acts as a slave and monitors the current

information for current sharing. The voltage drops across the current sense resistors (or DCR of inductors) are measured and their difference is amplified by the slave error amplifier and compared with the ramp signal to generate the PWM pulses to match the output current. In this mode the SS2 pin should be floating.

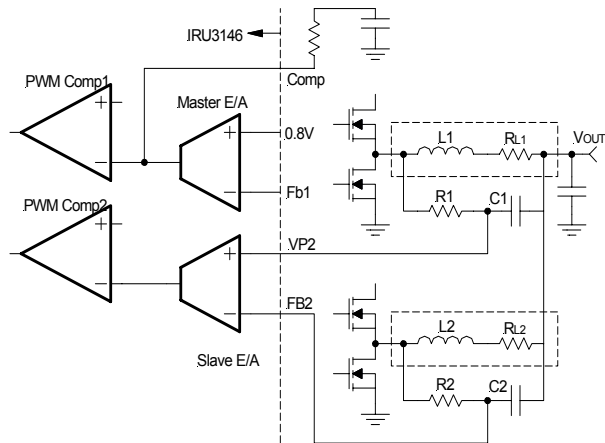

Figure 4 - Loss-less inductive current sensing and current sharing.

In the diagram, L₁ and L₂ are the output inductors. R_{L1} and R_{L2} are inherent inductor resistances. The resistor R₁ and capacitor C₁ are used to sense the average inductor current. The voltage across the capacitors C₁ and C₂ represent the average current flowing into resistance R_{L1} and R_{L2}. The time constant of the RC network should be equal or at most three times larger than the time constant L₁/R_{L1}.

$$R_1 \times C_1 = (1 \sim 3) \times \frac{L_1}{R_{L1}} \quad \text{---(1)}$$

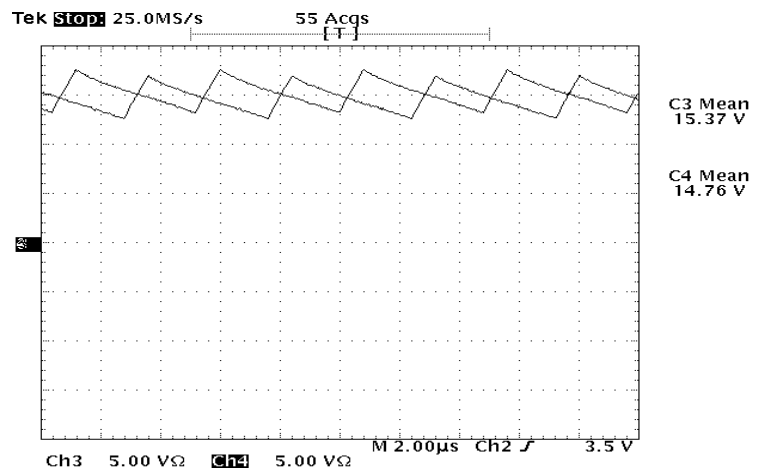

Figure 5 - 30A Current Sharing using Inductor sensing (5A/Div)

Dual Soft-Start

The IRU3146 has programmable soft-start to control the output voltage rise and limit the inrush current during start-up. It provides a separate Soft-Start function for each outputs. This will enable to sequence the outputs by controlling the rise time of each output through selection of different value soft-start capacitors. The soft-start pins will be connected together for applications where, both outputs are required to ramp-up at the same time.

To ensure correct start-up, the soft-start sequence initiates when the VCC, VCH1 and VCH2 rise above their threshold (4.2V and 3.5V respectively) and generate the Power On Reset (POR) signal. Soft-start function operates by sourcing an internal current to charge an external capacitor to about 3V. Initially, the soft-start function clamps the E/A's output of the PWM converter. During power up, the converter output starts at zero and thus the voltage at Fb is about 0V. A current (64µA) injects into the Fb pin and generates a voltage about 1.6V (64µA × 25K) across the negative input of E/A and (see Figure6).

The magnitude of this current is inversely proportional to the voltage at soft-start pin. The 25µA current source starts to charge up the external capacitor. In the mean time, the soft-start voltage ramps up, the current flowing into Fb pin starts to decrease linearly and so does the voltage at negative input of E/A.

When the soft-start capacitor is around 1V, the current flowing into the Fb pin is approximately 32µA. The voltage at the positive input of the E/A is approximately:

$$32\mu\text{A} \times 25\text{K} = 0.8\text{V}$$

The E/A will start to operate and the output voltage starts to increase. As the soft-start capacitor voltage continues to go up, the current flowing into the Fb pin will keep decreasing. Because the voltage at pin of E/A is regulated to reference voltage 0.8V, the voltage at the Fb is:

$$V_{\text{FB}} = 0.8 - (25\text{K} \times \text{Injected Current})$$

The feedback voltage increases linearly as the injecting current goes down. The injecting current drops to zero when soft-start voltage is around 2V and the output voltage goes into steady state. Figure 7 shows the theoretical operational waveforms during soft-start.

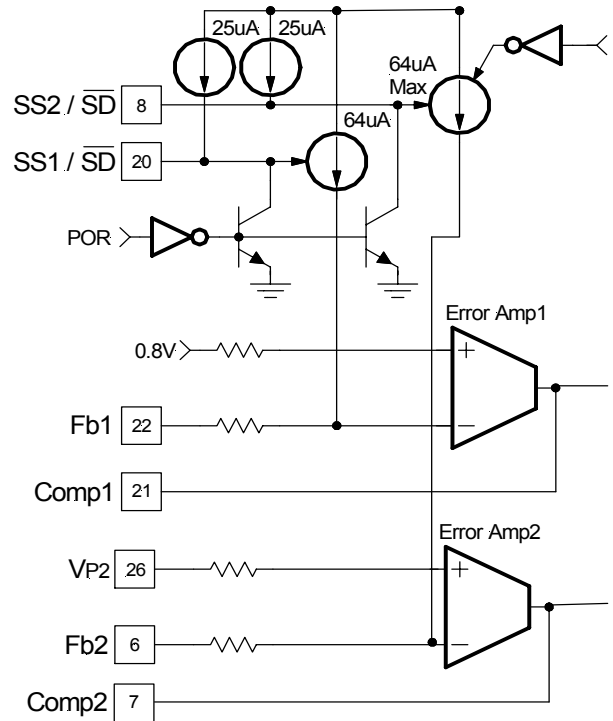

Figure 6 -Soft-start circuit for IRU3146

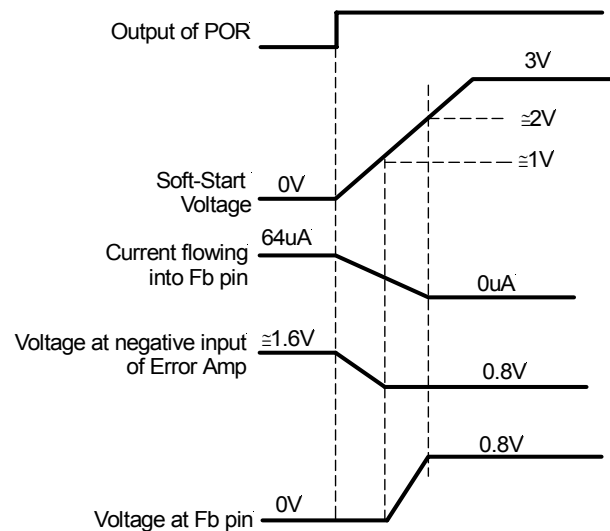

Figure 7 - Theoretical operational waveforms during soft-start.

The output start-up time is the time period when soft-start capacitor voltage increases from 1V to 2V. The start-up time will be dependent on the size of the external soft-start capacitor. The start-up time can be estimated by:

$$25\mu\text{A} \times T_{\text{START}}/C_{\text{SS}} = 2\text{V}-1\text{V}$$

For a given start up time, the soft-start capacitor can be calculated by:

$$C_{SS} \cong 25\mu A \times T_{START}/1V$$

The soft-start is part of Over Current Protection scheme, during the overload or short circuit condition the external soft start capacitors will be charged and discharged in certain slope rate to achieve the hiccup mode function.

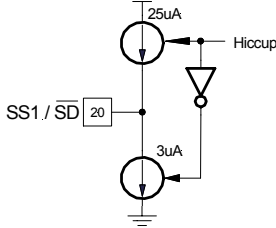

Figure 8 - 3uA current source for discharging soft start-capacitor during Hiccup mode

Out-of-Phase Operation

The IRU3146 drives its two output stages 180° out-of-phase. In 2-phase configuration, the two inductor ripple currents cancel each other and result in a reduction of the output current ripple and yield a smaller output capacitor for the same ripple voltage requirement.

In single input voltage applications, the input ripple current reduces. This result in much smaller input capacitor's RMS current and reduces the input capacitor quantity.

Over-Current Protection

The IRU3146 can provide two different schemes for Over-Current Protection (OCP). When the pin Hiccup is pulled high, the OCP will operate in hiccup mode. In this mode, during overload or short circuit, the outputs enter hiccup mode and stay in that mode until the overload or short circuit is removed. The converter will automatically recover.

When the Hiccup pin is pulled low, the OCP scheme will be changed to the latch up type, in this mode the converter will be turned off during Overcurrent or short circuit. The power needs to be recycled for normal operation.

Each phase has its own independent OCP circuitry. The OCP is performed by sensing current through the $R_{DS(ON)}$ of low side MOSFET. As shown in Figure 9, an external resistor (R_{SET}) is connected between OCSet pin and the drain of low side MOSFET (Q2) which sets the current limit set point.

If using one soft start capacitor in dual configuration for a precise power up the OCP needs to be set to latch mode.

The internal current source develops a voltage across R_{SET} . When the low side switch is turned on, the inductor current flows through the Q2 and results a voltage which is given by:

$$V_{OCSET} = I_{OCSET} \times R_{SET} - R_{DS(ON)} \times I_L \quad \text{---(2)}$$

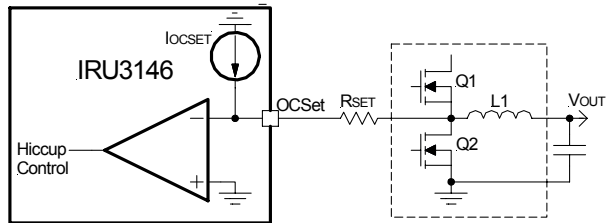

Figure 9 - Diagram of the over current sensing.

The critical inductor current can be calculated by setting:

$$V_{OCSET} = I_{OCSET} \times R_{SET} - R_{DS(ON)} \times I_L = 0$$

$$I_{SET} = I_{L(CRITICAL)} = \frac{R_{SET} \times I_{OCSET}}{R_{DS(ON)}} \quad \text{---(3)}$$

The value of R_{SET} should be checked in an actual circuit to ensure that the Over Current Protection circuit activates as expected. The IRU3146 current limit is designed primarily as disaster preventing, "no blow up" circuit, and is not useful as a precision current regulator.

In two independent mode, the output of each channel is protected independently which means if one output is under overload or short circuit condition, the other output will remain functional. The OCP set limit can be programmed to different levels by using the external resistors. This is valid for both hiccup mode and latch up mode.

In 2-phase configuration, the OCP's output depends on any one channel, which means as soon as one channel goes to overload or short circuit condition the output will enter either hiccup or latch-up, depends on status of Hiccup pin.

Frequency Synchronization

The IRU3146 is capable of accepting an external digital synchronization signal. Synchronization will be enabled by the rising edge at an external clock. Per-channel switching frequency is set by external resistor (Rt). The free running oscillator frequency is twice the per-channel frequency. During synchronization, Rt is selected such that the free running frequency is 20% below the sync frequency. Synchronization capability is provided for both 2-output and 2-phase configurations. When unused, the Sync pin will remain floating and is noise immune.

Thermal Shutdown

Temperature sensing is provided inside IRU3146. The trip threshold is typically set to 140°C. When trip threshold is exceeded, thermal shutdown turns off both FETs. Thermal shutdown is not latched and automatic restart is initiated when the sensed temperature drops to normal range. There is a 20°C hysteresis in the shutdown threshold.

Power Good

The IRU3146 provides a power good signal. The power good signal should be available after both outputs have reached regulation. This pin needs to be externally pulled high. High state indicates that outputs are in regulation. Power good will be low if either one of the output voltages is 10% below the set value. There is only one power good for both outputs.

Over-Voltage Protection OVP

Over-voltage is sensed through separate V_{OUT} sense pins Vsen1 and Vsen2. A separate OVP circuit is provided for each output. Upon over-voltage condition of either one of the outputs, the OVP forces a latched shutdown on both outputs. In this mode, the upper FET drivers turn-off and the lower FET drivers turn-on, thus crowbaring the outputs. Reset is performed by recycling either Vcc.

Error Amplifier

The IRU3146 is a voltage mode controller. The error amplifiers are of transconductance type. In independent mode, each amplifier closes the loop around its own output voltage. In current sharing mode, amplifier 1 becomes the master which regulates the common output voltage. Amplifier 2 performs the current sharing function. Both amplifiers are capable of operating with Type III compensation control scheme.

Low Temperature Start-Up

The controller is capable of starting at -40°C ambient temperature.

Operation Frequency Selection

The optimum operating frequency range for IRU3146 is 300KHz per phase, theoretically the IRU3146 can be operated at higher switching frequency (e.g. 500KHz). However the power dissipation for IC, which is function of applied voltage, gate drivers load and switching frequency, will result in higher junction temperature of device. It may exceed absolute maximum rating of junction temperature, figure 18 (page 16) shows case temperature versus switching frequency with different capacitive loads.

This should be considered when using IRU3146 for such application. The below equation shows the relationship between IC's maximum power dissipation and Junction temperature:

$$P_d = \frac{T_j - T_A}{\theta_{JA}}$$

Where:

T_j: Maximum Operating Junction Temperature (125°C)

T_A: Ambient Temperature (70°C)

θ_{JA} = Thermal Impedance of package (84°C/W)

For T_j=125°C T_A=70°C and θ_{JA}=84°C/W

This will result to power dissipation of 650mW, this includes biasing current for all four external MOSFETs and IC's biasing current.

The switching frequency is determined by an external resistor (Rt). The switching frequency is approximately inversely proportioned to resistance (see Fig 10).

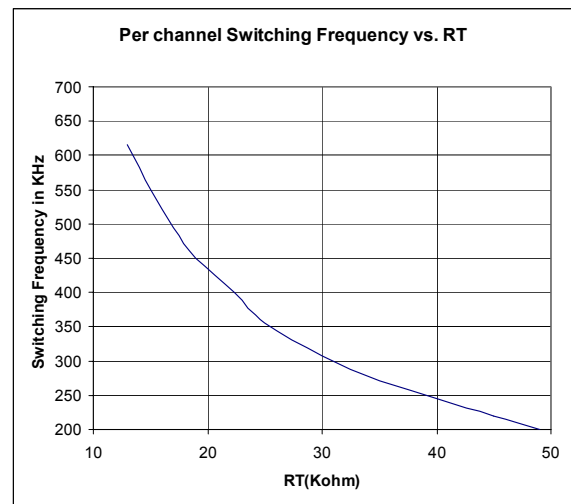

Figure 10- Switching Frequency versus External Resistor.

Shutdown

The outputs can be shutdown independently by pulling the respective soft-start pins below 0.3V. This can be easily done by using an external small signal transistor. During shutdown both MOSFETs will be turned off. During this mode the LDO will stay on. Cycling soft-start pins will clear all fault latches and normal operation will resume.

APPLICATION INFORMATION

Design Example:

The following example is a typical application for IRU3146, the schematic is Figure 18 on page 17.

$$\begin{aligned} V_{IN} &= 12V \\ V_{OUT(2.5V)} &= 2.5V @ 10A \\ V_{OUT(1.8V)} &= 1.8V @ 10A \\ \Delta V_{OUT} &= \text{Output voltage ripple} \cong 3\% \text{ of } V_{OUT} \\ F_s &= 300KHz \end{aligned}$$

Output Voltage Programming

Output voltage is programmed by reference voltage and external voltage divider. The Fb1 pin is the inverting input of the error amplifier, which is referenced to the voltage on non-inverting pin of error amplifier. For this application, this pin (V_P) is connected to reference voltage (V_{REF}). The output voltage is defined by using the following equation:

$$V_{OUT} = V_P \times \left(1 + \frac{R_6}{R_5}\right) \quad \text{---(4)}$$

$$V_{P2} = V_{REF} = 0.8V$$

When an external resistor divider is connected to the output as shown in Figure 11.

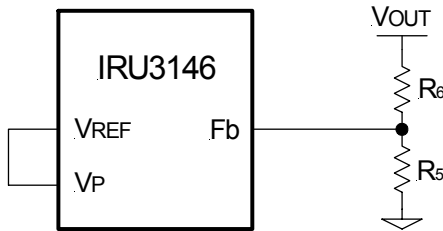

Figure 11 - Typical application of the IRU3146 for programming the output voltage.

Equation (4) can be rewritten as:

$$R_6 = R_5 \times \left(\frac{V_{OUT}}{V_P} - 1\right)$$

Will result to:

$$\begin{aligned} V_{OUT(2.5V)} &= 2.5V & V_{OUT(1.8V)} &= 1.8V \\ V_{REF} &= 0.8V & V_{REF} &= 0.8 \\ R_9 &= 2.14K, R_5 &= 1K & R_7 = 1.24K, R_8 = 1K \end{aligned}$$

If the high value feedback resistors are used, the input bias current of the Fb pin could cause a slight increase in output voltage. The output voltage can be set more accurately by using low value, precision resistors.

Soft-Start Programming

The soft-start timing can be programmed by selecting the soft-start capacitance value. The start-up time of the converter can be calculated by using:

$$C_{SS} \cong 25 \times t_{START} \quad (\mu F) \quad \text{---(5)}$$

Where t_{START} is the desired start-up time (ms)

For a start-up time of 4ms for both output, the soft-start capacitor will be 0.1 μ F. Connect ceramic capacitors at 0.1 μ F from SS1 pin and SS2 pin to GND.

Supply VCH1 and VCH2

To drive the high side switch, it is necessary to supply a gate voltage at least 4V greater than the bus voltage. This is achieved by using a charge pump configuration as shown in Figure 12. This method is simple and inexpensive. The operation of the circuit is as follows: when the lower MOSFET is turned on, the capacitor (C_1) charges up to V_{OUT3} , through the diode (D_1). The bus voltage will be added to this voltage when upper MOSFET turns on in next cycle, and providing supply voltage (V_{CH1}) through diode (D_2). V_c is approximately:

$$V_{CH1} \cong V_{OUT3} + V_{BUS} - (V_{D1} + V_{D2})$$

Capacitors in the range of 0.1 μ F and 1 μ F are generally adequate for most applications. The diode must be a fast recovery device to minimize the amount of charge fed back from the charge pump capacitor into V_{OUT3} . The diodes need to be able to block the full power rail voltage, which is seen when the high side MOSFET is switched on. For low voltage application, schottky diodes can be used to minimize forward drop across the diodes at start up.

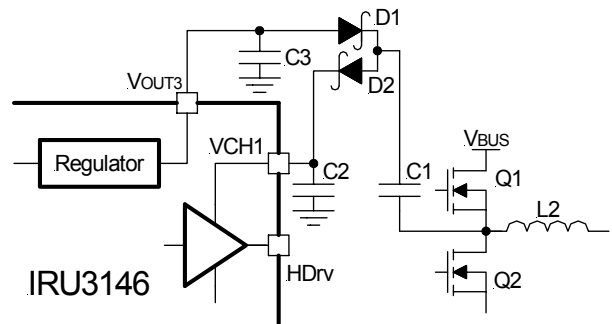

Figure 12 - Charge pump circuit.

Input Capacitor Selection

The 180° out of phase will reduce the RMS value of the ripple current seen by input capacitors. This reduces numbers of input capacitors. The input capacitors must be selected that can handle both the maximum ripple RMS at highest ambient temperature as well as the maximum input voltage. The RMS value of current ripple for duty cycles under 50% is expressed by:

$$I_{RMS} = \sqrt{I_1^2 D_1 (1-D_1) + I_2^2 D_2 (1-D_2) - 2 I_1 I_2 D_1 D_2} \quad \text{--- (6)}$$

Where:

I_{RMS} is the RMS value of the input capacitor current
 D_1 and D_2 are the duty cycle for each output
 I_1 and I_2 are the current for each output
 For this application the $I_{RMS} = 4.8A$

For higher efficiency, low ESR capacitors is recommended.

Choose two Poscap from Sanyo 16TPB47M (16V, 47 μ F, 70m Ω) with a maximum allowable ripple current of 1.4A for inputs of each channel.

Inductor Selection

The inductor is selected based on operating frequency, transient performance and allowable output voltage ripple. Low inductor value results to faster response to step load (high $\Delta i/\Delta t$) and smaller size but will cause larger output ripple due to increase of inductor ripple current. As a rule of thumb, select an inductor that produces a ripple current of 10-40% of full load DC.

For the buck converter, the inductor value for desired operating ripple current can be determined using the following relation:

$$V_{IN} - V_{OUT} = L \times \frac{\Delta i}{\Delta t} ; \Delta t = D \times \frac{1}{f_s} ; D = \frac{V_{OUT}}{V_{IN}}$$

$$L = (V_{IN} - V_{OUT}) \times \frac{V_{OUT}}{V_{IN} \times \Delta i \times f_s} \quad \text{---(7)}$$

Where:

V_{IN} = Maximum Input Voltage
 V_{OUT} = Output Voltage
 Δi = Inductor Ripple Current
 f_s = Switching Frequency
 Δt = Turn On Time
 D = Duty Cycle

For $\Delta i_{(2.5V)} = 38\%(I_{O(2.5V)})$, then the output inductor will be:

$$L_4 = 1.71\mu H$$

For $\Delta i_{(1.8V)} = 30\%(I_{O(1.8V)})$, then the output inductor will be:

$$L_3 = 1.7\mu H$$

Panasonic provides a range of inductors in different values and low profile for large currents.

Choose ETQP6F1R8BFA (1.71 μ H, 14A, 3.3m Ω) both for L_3 and L_4 .

For 2-phase application, equation (7) can be used for calculating the inductors value. In such case the inductor ripple current is usually chosen to be between 10-40% of maximum phase current.

Output Capacitor Selection

The criteria to select the output capacitor is normally based on the value of the Effective Series Resistance (ESR). In general, the output capacitor must have low enough ESR to meet output ripple and load transient requirements, yet have high enough ESR to satisfy stability requirements. The ESR of the output capacitor is calculated by the following relationship: (ESL, Equivalent Series Inductance is neglected)

$$ESR \leq \frac{\Delta V_o}{\Delta I_o} \quad \text{---(8)}$$

Where:

ΔV_o = Output Voltage Ripple

Δi = Inductor Ripple Current

$\Delta V_o = 3\%$ of V_o will result to $ESR_{(2.5V)} = 19.7m\Omega$ and $ESR_{(1.8V)} = 16m\Omega$

The Sanyo TPC series, Poscap capacitor is a good choice. The 6TPC330M, 330 μ F, 6.3V has an ESR 40m Ω . Selecting two of these capacitors in parallel for 2.5V output, results to an ESR of $\cong 20m\Omega$ which achieves our low ESR goal. And selecting four of these capacitors in parallel for 1.8V output, results to an ESR of $\cong 10m\Omega$ which achieves our low ESR goal.

The capacitors value must be high enough to absorb the inductor's ripple current.

Power MOSFET Selection

The IRU3146 uses four N-Channel MOSFETs. The selections criteria to meet power transfer requirements is based on maximum drain-source voltage (V_{DSS}), gate-source drive voltage (V_{GS}), maximum output current, On-resistance $R_{DS(ON)}$ and thermal management.

The both control and synchronous MOSFETs must have a maximum operating voltage (V_{DSS}) that exceeds the maximum input voltage (V_{IN}).

The gate drive requirement is almost the same for both MOSFETs. Logic-level transistor can be used and caution should be taken with devices at very low V_{GS} to prevent undesired turn-on of the complementary MOSFET, which results in shoot-through.

The total power dissipation for MOSFETs includes conduction and switching losses. For the Buck converter, the average inductor current is equal to the DC load current. The conduction loss is defined as:

$$P_{COND}(Upper\ Switch) = I_{LOAD}^2 \times R_{DS(ON)} \times D \times \vartheta$$

$$P_{COND}(Lower\ Switch) = I_{LOAD}^2 \times R_{DS(ON)} \times (1 - D) \times \vartheta$$

$\vartheta = R_{DS(ON)}$ Temperature Dependency

The $R_{DS(ON)}$ temperature dependency should be considered for the worst case operation. This is typically given in the MOSFET data sheet. Ensure that the conduction losses and switching losses do not exceed the package ratings or violate the overall thermal budget.

Choose IRF7457 both for control and synchronous MOSFET. This device provide low on-resistance in a compact SOIC 8-Pin package.

The MOSFET have the following data:

IRF7457
 $V_{DSS} = 20V$
 $I_D = 15A$
 $R_{DS(ON)} = 7m\Omega$

The total conduction losses for each output will be:

$$P_{CON(TOTAL, 2.5V)} = P_{CON(UPPER)} + P_{CON(LOWER)}$$

$$P_{CON(TOTAL, 2.5V)} = 1.0W$$

$$P_{CON(TOTAL, 1.8V)} = P_{CON(UPPER)} + P_{CON(LOWER)}$$

$$P_{CON(TOTAL, 1.8V)} = 1.0W$$

The switching loss is more difficult to calculate, even though the switching transition is well understood. The reason is the effect of the parasitic components and switching times during the switching procedures such as turn-on / turnoff delays and rise and fall times. The control MOSFET contributes to the majority of the switching losses in a synchronous Buck converter. The synchronous MOSFET turns on under zero voltage conditions, therefore, the switching losses for synchronous MOSFET can be neglected. With a linear approximation, the total switching loss can be expressed as:

$$P_{SW} = \frac{V_{DS(OFF)}}{2} \times \frac{t_r + t_f}{T} \times I_{LOAD} \quad \text{---(9)}$$

Where:

$V_{DS(OFF)}$ = Drain to Source Voltage at off time
 t_r = Rise Time
 t_f = Fall Time
 T = Switching Period
 I_{LOAD} = Load Current

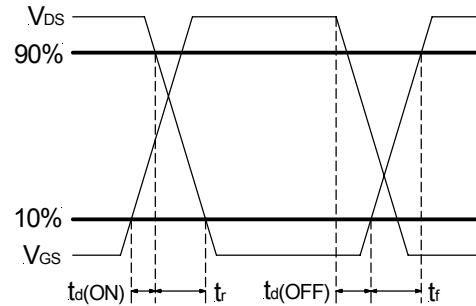

Figure 13 - Switching time waveforms.

From IRF7457 data sheet we obtain:

IRF7457
 $t_r = 16ns$
 $t_f = 7ns$

These values are taken under a certain condition test. For more details please refer to the IRF7457 data sheet.

By using equation (9), we can calculate the total switching losses.

$$P_{SW(TOTAL, 2.5V)} = 0.414W$$

$$P_{SW(TOTAL, 1.8V)} = 0.414W$$

Programming the Over-Current Limit

The over-current threshold can be set by connecting a resistor (R_{SET}) from drain of low side MOSFET to the OCSet pin. The resistor can be calculated by using equation (3).

The $R_{DS(ON)}$ has a positive temperature coefficient and it should be considered for the worse case operation.

$$R_{DS(ON)} = 7m\Omega \times 1.5 = 10.5m\Omega$$

$$I_{SET} \equiv I_{O(LIM)} = 10A \times 1.5 = 15A$$

(50% over nominal output current)

This results to:
 $R_{SET} = R_1 = R_6 = 7.8K\Omega$

Feedback Compensation

The IRU3146 is a voltage mode controller; the control loop is a single voltage feedback path including error amplifier and error comparator. To achieve fast transient response and accurate output regulation, a compensation circuit is necessary. The goal of the compensation network is to provide a closed loop transfer function with the highest 0dB crossing frequency and adequate phase margin (greater than 45°).

The output LC filter introduces a double pole, -40dB/decade gain slope above its corner resonant frequency, and a total phase lag of 180° (see Figure 14). The Resonant frequency of the LC filter is expressed as follows:

$$F_{LC} = \frac{1}{2\pi \times \sqrt{L_o \times C_o}} \quad \text{---(10)}$$

Where: L_o is the output inductor
 For 2-phase application, the effective output inductance should be used

C_o is the total output capacitor

Figure 14 shows gain and phase of the LC filter. Since we already have 180° phase shift just from the output

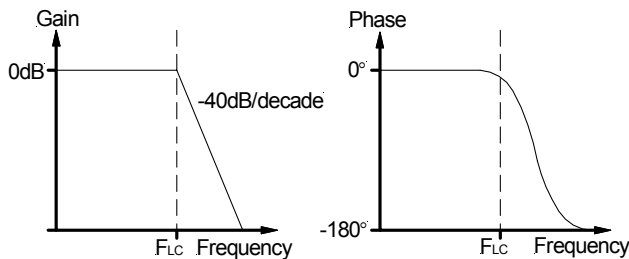

Figure14 - gain and phase of LC filter

The IRU3146's error amplifier is a differential-input transconductance amplifier. The output is available for DC gain control or AC phase compensation. The E/A can be compensated with or without the use of local feedback. When operated without local feedback, the transconductance properties of the E/A become evident and can be used to cancel one of the output filter poles. This will be accomplished with a series RC circuit from Comp pin to ground as shown in Figure 15.

Note that this method requires the output capacitor to have enough ESR to satisfy stability requirements. In general, the output capacitor's ESR generates a zero typically at 5KHz to 50KHz which is essential for an acceptable phase margin.

The ESR zero of the output capacitor is expressed as follows:

$$F_{ESR} = \frac{1}{2\pi \times ESR \times C_o} \quad \text{---(10A)}$$

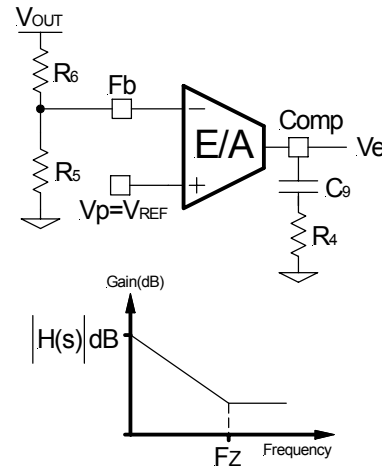

Figure 15 - Compensation network without local feedback and its asymptotic gain plot.

The transfer function (V_e / V_{OUT}) is given by:

$$H(s) = \left(g_m \times \frac{R_5}{R_6 + R_5} \right) \times \frac{1 + sR_4C_9}{sC_9} \quad \text{---(11)}$$

The (s) indicates that the transfer function varies as a function of frequency. This configuration introduces a gain and zero, expressed by:

$$|H(s=j \times 2\pi \times F_o)| = g_m \times \frac{R_5}{R_6+R_5} \times R_4 \quad \text{---(12)}$$

$$F_z = \frac{1}{2\pi \times R_4 \times C_9} \quad \text{---(13)}$$

$|H(s)|$ is the gain at zero cross frequency. First select the desired zero-crossover frequency (F_{O1}):

$$F_{O1} > F_{ESR} \text{ and } F_{O1} \leq (1/5 \sim 1/10) \times f_s$$

$$R_4 = \frac{V_{OSC}}{V_{IN}} \times \frac{F_{O1} \times F_{ESR}}{F_{LC}^2} \times \frac{R_5 + R_6}{R_5} \times \frac{1}{g_m} \quad \text{---(14)}$$

Where:

- V_{IN} = Maximum Input Voltage
- V_{OSC} = Oscillator Ramp Voltage
- F_{O1} = Crossover Frequency
- F_{ESR} = Zero Frequency of the Output Capacitor
- F_{LC} = Resonant Frequency of the Output Filter
- R_5 and R_6 = Resistor Dividers for Output Voltage Programming
- g_m = Error Amplifier Transconductance

For $V_{2.5V}$:

- $V_{IN} = 12V$
- $V_{OSC} = 1.25V$
- $F_{O1} = 30KHz$
- $F_{ESR} = 12KHz$
- $F_{LC} = 4.75KHz$
- $R_5 = 1K$
- $R_6 = 2.14K$
- $g_m = 2000\mu mho$

This results to $R_4=2.61K$
Choose $R_4=2.61K$

To cancel one of the LC filter poles, place the zero before the LC filter resonant frequency pole:

$$F_z \cong 75\%F_{LC}$$

$$F_z \cong 0.75 \times \frac{1}{2\pi \sqrt{L_o \times C_o}} \quad \text{---(15)}$$

For:

- $L_o = 1.71\mu H$
- $C_o = 660\mu F$
- $F_z = 3.56KHz$
- $R_4 = 2.61K$

Using equations (13) and (15) to calculate C_9 , we get:

$$C_9 \cong 17.18nF; \text{ Choose } C_9=18nF$$

Same calculation For $V_{1.8V}$ will result to: $R_3 = 2.8K$ and $C_8 = 22nF$

One more capacitor is sometimes added in parallel with C_9 and R_4 . This introduces one more pole which is mainly used to suppress the switching noise. The additional pole is given by:

$$F_P = \frac{1}{2\pi \times R_4 \times \frac{C_9 \times C_{POLE}}{C_9 + C_{POLE}}}$$

The pole sets to one half of switching frequency which results in the capacitor C_{POLE} :

$$C_{POLE} = \frac{1}{\pi \times R_4 \times f_s} - \frac{1}{C_9} \cong \frac{1}{\pi \times R_4 \times f_s}$$

$$\text{for } F_P \ll \frac{f_s}{2}$$

For a general solution for unconditional stability for ceramic output capacitor with very low ESR or any type of output capacitors, in a wide range of ESR values we should implement local feedback with a compensation network. The typically used compensation network for a voltage-mode controller is shown in Figure 16.

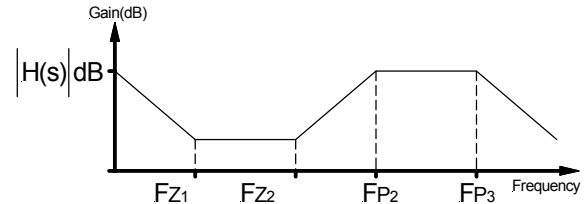
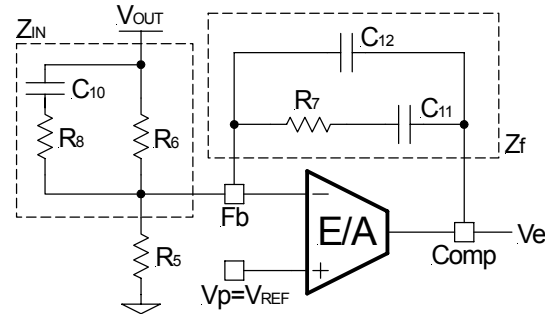

Figure 16- Compensation network with local feedback and its asymptotic gain plot.

In such configuration, the transfer function is given by:

$$\frac{V_e}{V_{OUT}} = \frac{1 - g_m Z_f}{1 + g_m Z_{IN}}$$

The error amplifier gain is independent of the transconductance under the following condition:

$$g_m Z_f \gg 1 \quad \text{and} \quad g_m Z_{IN} \gg 1 \quad \text{---(16)}$$

By replacing Z_{IN} and Z_f according to Figure 16, the transfer function can be expressed as:

$$H(s) = \frac{1}{sR_6(C_{12}+C_{11})} \times \frac{(1+sR_7C_{11}) \times [1+sC_{10}(R_6+R_8)]}{\left[1+sR_7\left(\frac{C_{12}C_{11}}{C_{12}+C_{11}}\right)\right] \times (1+sR_8C_{10})}$$

As known, transconductance amplifier has high impedance (current source) output, therefore, consider should be taken when loading the E/A output. It may exceed its source/sink output current capability, so that the amplifier will not be able to swing its output voltage over the necessary range.

The compensation network has three poles and two zeros and they are expressed as follows:

$$F_{P1} = 0$$

$$F_{P2} = \frac{1}{2\pi \times R_8 \times C_{10}}$$

$$F_{P3} = \frac{1}{2\pi \times R_7 \times \left(\frac{C_{12} \times C_{11}}{C_{12} + C_{11}} \right)} \cong \frac{1}{2\pi \times R_7 \times C_{12}}$$

$$F_{Z1} = \frac{1}{2\pi \times R_7 \times C_{11}}$$

$$F_{Z2} = \frac{1}{2\pi \times C_{10} \times (R_6 + R_8)} \cong \frac{1}{2\pi \times C_{10} \times R_6}$$

Cross Over Frequency:

$$F_o = R_7 \times C_{10} \times \frac{V_{IN}}{V_{OSC}} \times \frac{1}{2\pi \times L_o \times C_o} \quad \text{---(17)}$$

Where:

- V_{IN} = Maximum Input Voltage
- V_{OSC} = Oscillator Ramp Voltage
- L_o = Output Inductor
- C_o = Total Output Capacitors

The stability requirement will be satisfied by placing the poles and zeros of the compensation network according to following design rules. The consideration has been taken to satisfy condition (16) regarding transconductance error amplifier.

These design rules will give a crossover frequency approximately one-tenth of the switching frequency. The higher the band width, the potentially faster the load transient response. The DC gain will be large enough to provide high DC-regulation accuracy (typically -5dB to -12dB). The phase margin should be greater than 45° for overall stability.

Based on the frequency of the zero generated by ESR versus crossover frequency, the compensation type can be different. The table below shows the compensation type and location of crossover frequency.

Compensator Type	Location of Zero Crossover Frequency (Fo)	Typical Output Capacitor
Type II (PI)	$F_{P0} < F_{Z0} < F_o < f_s/2$	Electrolytic, Tantalum
Type III (PID) Method A	$F_{P0} < F_o < F_{Z0} < f_s/2$	Tantalum, Ceramic
Type III (PID) Method B	$F_{P0} < F_o < f_s/2 < F_{Z0}$	Ceramic

Table - The compensation type and location of zero crossover frequency.

Details are discussed in application Note AN-1043 which can be downloaded from the IR Web-Site.

Compensation for Slave Error Amplifier for 2-Phase Configuration

The slave error amplifier is a differential-input transconductance amplifier, in 2-phase configuration the main goal for the slave feed back loop is to control the inductor current to match the masters inductor current as well provides highest bandwidth and adequate phase margin for overall stability. The following analysis is valid for both using external current sense resistor and using DCR of inductors.

The transfer function of power stage is expressed by:

$$G(s) = \frac{I_{L2}(s)}{V_e(s)} = \frac{V_{IN} - V_{OUT}}{sL_2 \times V_{OSC}} \quad \text{---(18)}$$

Where:

- V_{IN} = Input Voltage
- V_{OUT} = Output Voltage
- L_2 = Output Inductor
- V_{OSC} = Oscillator Peak Voltage

As shown the transfer function is a function of inductor current.

The transfer function for the compensation network is given by equation (19), when using a series RC circuit as shown in Figure 17:

$$D(s) = \frac{V_e(s)}{R_{S2} \times I_{L2}(s)} = \left(g_m \times \frac{R_{S1}}{R_{S2}} \right) \times \left(\frac{1 + sC_2R_2}{sC_2} \right) \quad \text{---(19)}$$

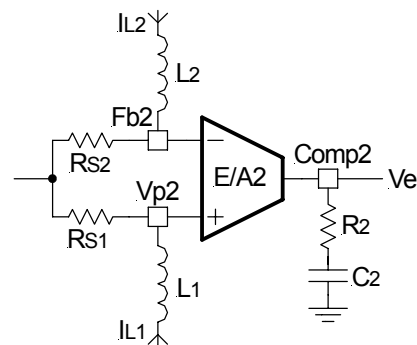

Figure 17 - The PI compensation network for slave channel.

The loop gain function is:

$$H(s) = [G(s) \times D(s) \times R_{S2}]$$

$$H(s) = R_{S2} \times \left(g_m \times \frac{R_{S1}}{R_{S2}} \right) \times \left(\frac{1 + sR_2C_2}{sC_2} \right) \times \left(\frac{V_{IN} - V_{OUT}}{sL_2 \times V_{OSC}} \right)$$

Select a zero crossover frequency for control loop (F_{O2}) 1.25 times larger than zero crossover frequency for voltage loop (F_{O1}):

$$F_{O2} \cong 1.25 \times F_{O1}$$

$$H(F_o) = g_m \times R_{S1} \times R_2 \times \frac{V_{IN} - V_{OUT}}{2\pi \times F_o \times L_2 \times V_{OSC}} = 1 \quad \text{---(20)}$$

From (20), R_2 can be express as:

$$R_2 = \frac{1}{g_m \times R_{S1}} \times \frac{2\pi \times F_{O2} \times L_2 \times V_{OSC}}{V_{IN} - V_{OUT}} \quad \text{---(21)}$$

Set the zero of compensator to be half of $F_{LC(SLAVE)}$, the compensator capacitor, C_2 , can be calculated as:

$$F_{LC(SLAVE)} = \frac{1}{2\pi \sqrt{L_2 \times C_{OUT}}}$$

$$F_Z = \frac{F_{LC(SLAVE)}}{2}$$

$$C_2 = \frac{1}{2\pi \times R_2 \times F_Z} \quad \text{---(22)}$$

When using the DCR of inductors as current sense element, replace R_{S1} in equation (21) with DCR value of inductor.

Layout Consideration

The layout is very important when designing high frequency switching converters. Layout will affect noise pickup and can cause a good design to perform with less than expected results.

Start by placing the power components. Make all the connections in the top layer with wide, copper filled areas. The inductor, output capacitor and the MOSFET should be as close to each other as possible. This helps to reduce the EMI radiated by the power traces due to the high switching. Place input capacitor near to the drain of the high-side MOSFET.

The layout of driver section should be designed for a low resistance (a wide, short trace) and low inductance (a wide trace with ground return path directly beneath it), this directly affects the driver's performance.

To reduce the ESR, replace the one input capacitor with two parallel ones. The feedback part of the system should be kept away from the inductor and other noise sources and must be placed close to the IC. In multilayer PCB's, use one layer as power ground plane and have a separate control circuit ground (analog ground), to which all signals are referenced. The goal is to localize the high current paths to a separate loops that does not interfere with the more sensitive analog control function. These two grounds must be connected together on the PC board layout at a single point.

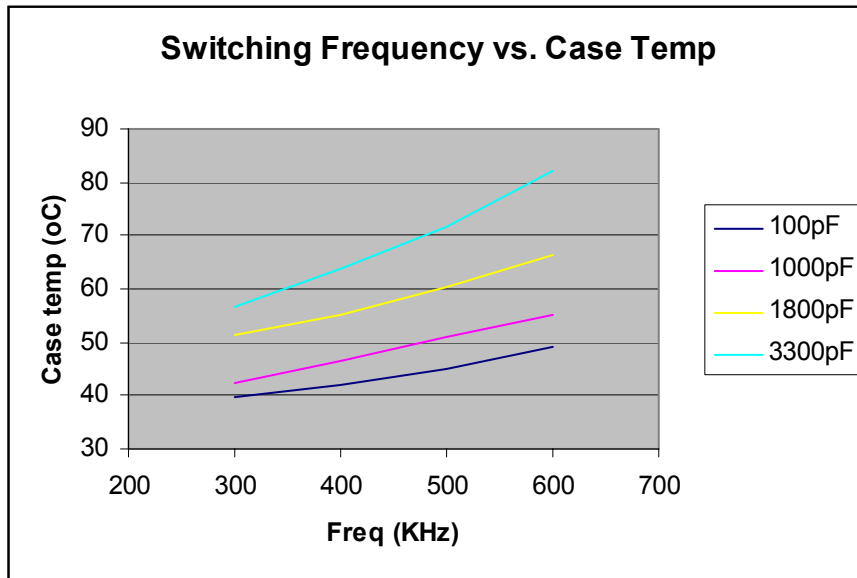

Figure18- Case Temperature versus Switching Frequency at Room Temperature
Test Condition: $V_{in}=V_{cl}=V_{ch1}=V_{ch2}=12V$, Capacitors used as loads for output drivers.

TYPICAL OPERATING CHARACTERISTICS

Test Conditions:

$V_{IN}=12V$, $V_{OUT1}=2.5V$, $I_{OUT1}=0-10A$, $V_{OUT2}=1.8V$, $I_{OUT2}=0-10A$, $F_s=300KHz$

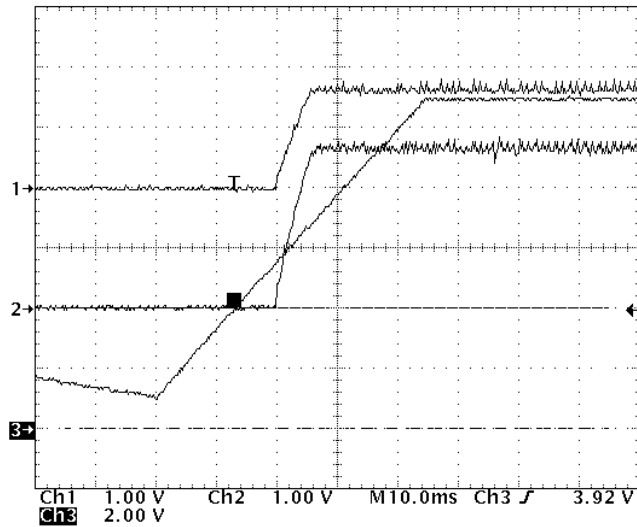

Figure 20 - Input Supply Ramps up.
Ch1: 1.8V, Ch2: 2.5V, Ch3: Input Supply

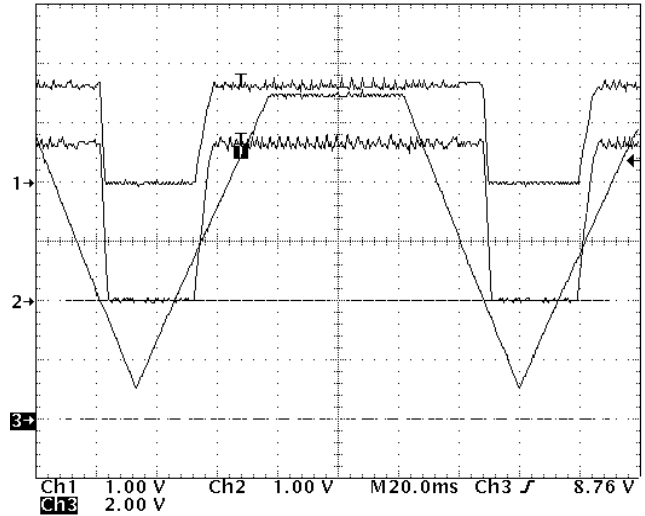

Figure 21 - Input Supply Ramps up/down.
Ch1: 1.8V, Ch2: 2.5V, Ch3: Input Supply

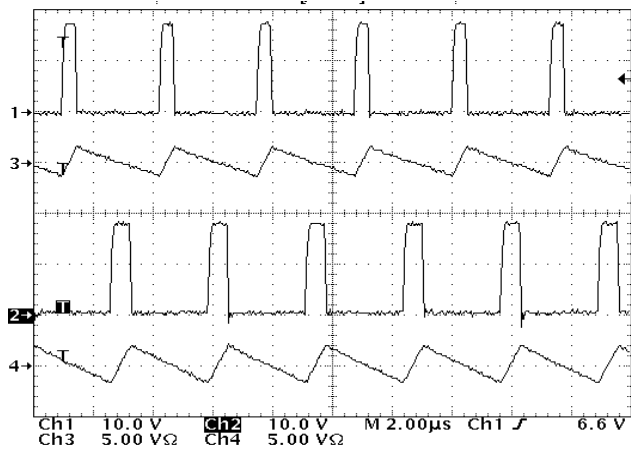

Figure 22 - Normal condition at No Load.
Ch1: HDrv2, Ch2: HDrv1, Ch3 and Ch4: Inductor
Currents
Ch3:ch4: 5A/div

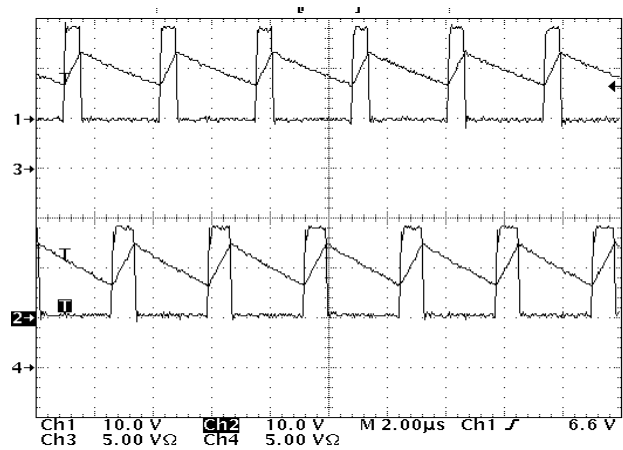

Figure 23 - Normal condition at 10A Load.
Ch1: HDrv2, Ch2: HDrv1, Ch3 and Ch4: Inductor
Currents
Ch3:ch4: 5A/div

TYPICAL OPERATING CHARACTERISTICS

Test Conditions:

$V_{IN}=12V$, $V_{OUT1}=2.5V$, $I_{OUT1}=0-10A$, $V_{OUT2}=1.8V$, $I_{OUT2}=0-10A$, $F_s=300KHz$

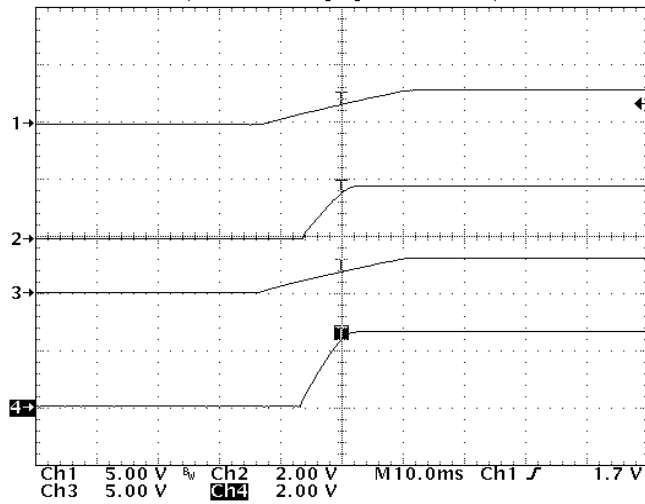

Figure 24 - Soft_Start.

Ch1: SS2, Ch2: 1.8V, Ch3: SS1, Ch4: 2.5V

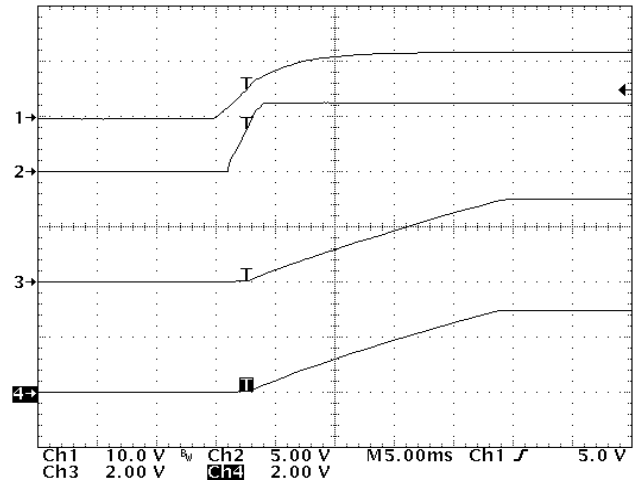

Figure 25 - Soft_Start.

Ch1: Vin, Ch2: Vout3(LDO), Ch3: SS2, Ch4: SS2

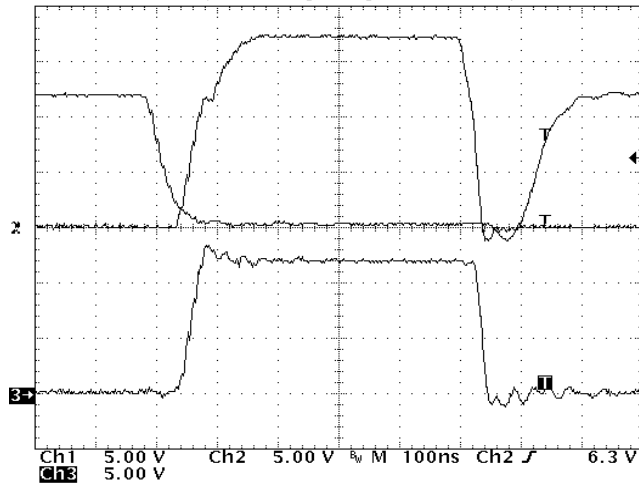

Figure 26 - Deadband Time (1.8V Output).

Ch1: LDrv2, Ch2: HDrv2, Ch3: Switching Node

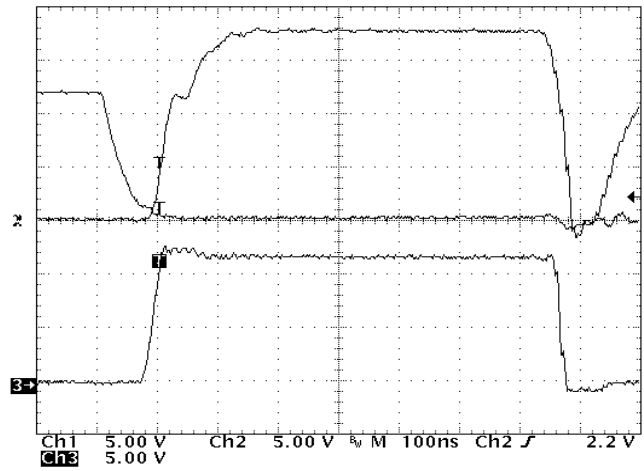

Figure 27 - Deadband Time (2.5V Output).

Ch1: LDrv1, Ch2: HDrv1, Ch3: Switching Node

TYPICAL OPERATING CHARACTERISTICS

Test Conditions:

$V_{IN}=12V, V_{OUT1}=2.5V, I_{OUT1}=0-10A, V_{OUT2}=1.8V, I_{OUT2}=0-10A, F_s=300KHz$

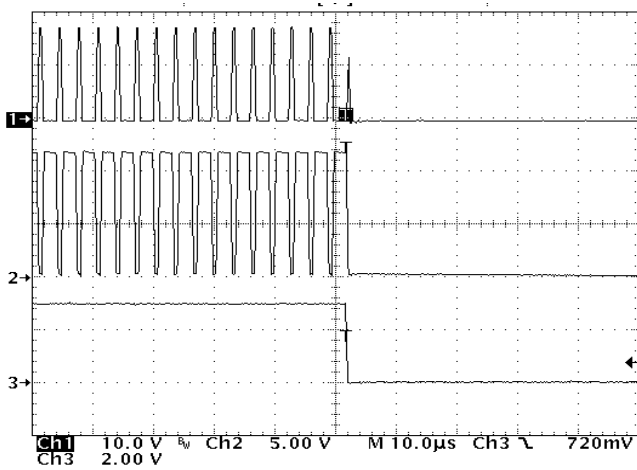

Figure 28 - Shut Down (Pulling down the SS1 pin).
Ch1: HDrv1, Ch2: LDrv1, Ch3: SS1

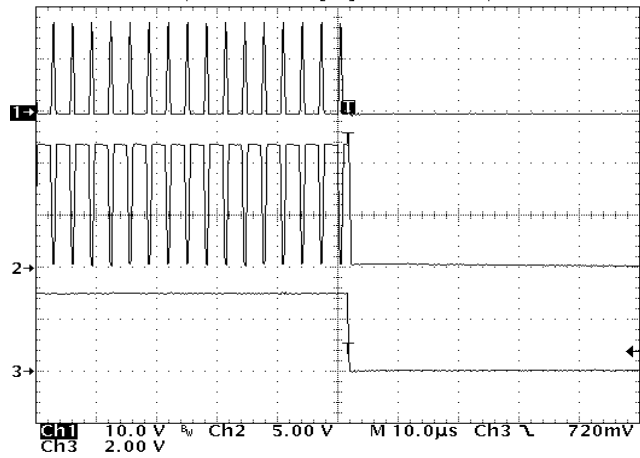

Figure 29 - Shut Down (pulling down the SS2 pin).
Ch1: HDrv2, Ch2: LDrv2, Ch3: SS2

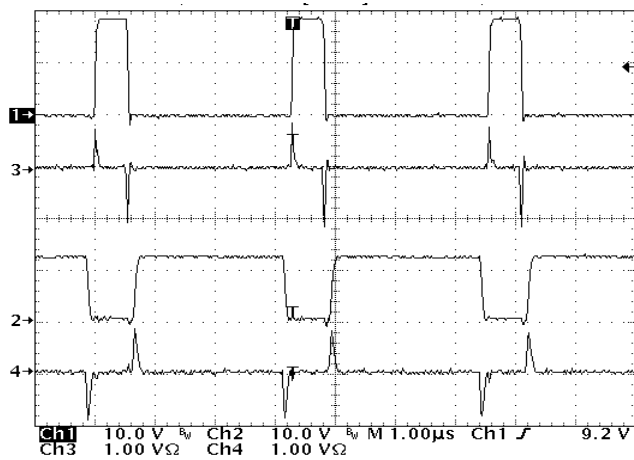

Figure 30 - High side and Low side Drivers peak Current for 1.8V Output

Ch1: HDrv2, Ch2: LDrv2, Ch3: High Side Peak Current, Ch4: Low Side Peak Current

Ch3:ch4: 1A/div

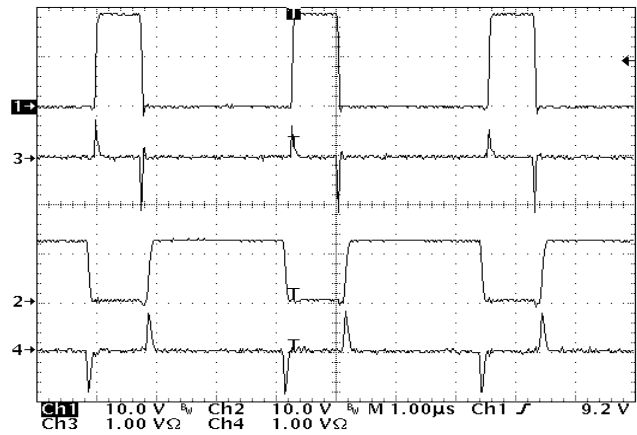

Figure 31 - High side and Low side Drivers peak Current for 2.5V Output

Ch1: HDrv1, Ch2: LDrv1, Ch3: High Side Peak Current, Ch4: Low Side Peak Current

Ch3:ch4: 1A/div

TYPICAL OPERATING CHARACTERISTICS

Test Conditions:

$V_{IN}=12V$, $V_{OUT1}=2.5V$, $I_{OUT1}=0-10A$, $V_{OUT2}=1.8V$, $I_{OUT2}=0-10A$, $F_s=300KHz$

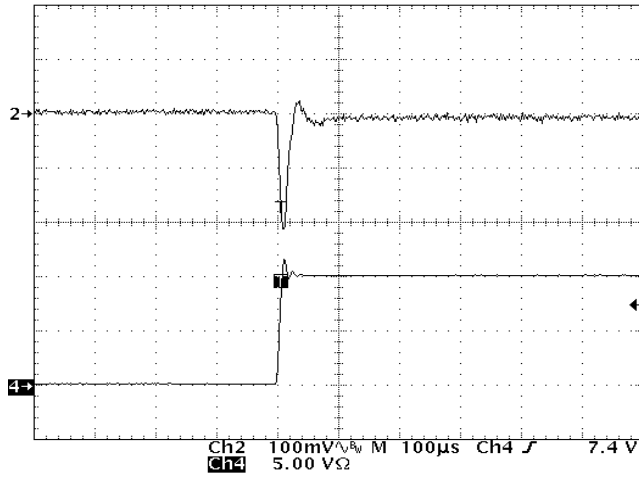

Figure 32 - Load Transient Response.
 Ch2: 2.5V, Ch4: Step Load (0-10A)
 Ch3:ch4: 5A/div

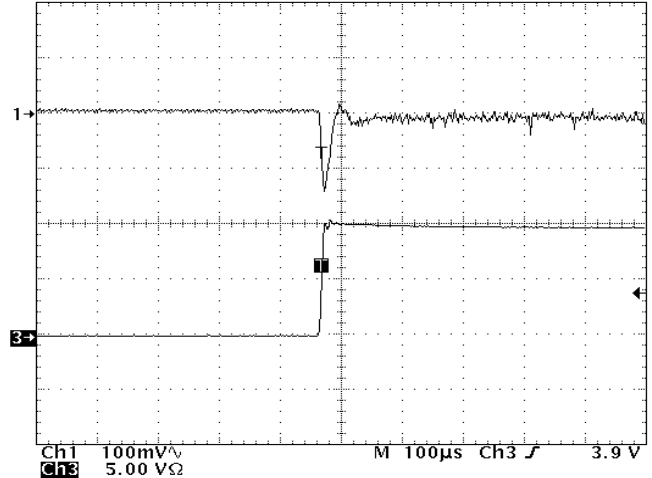

Figure 33 - Load Transient Response.
 Ch1: 1.8V, Ch3: Step Load (0-10A)
 Ch3:ch4: 5A/div

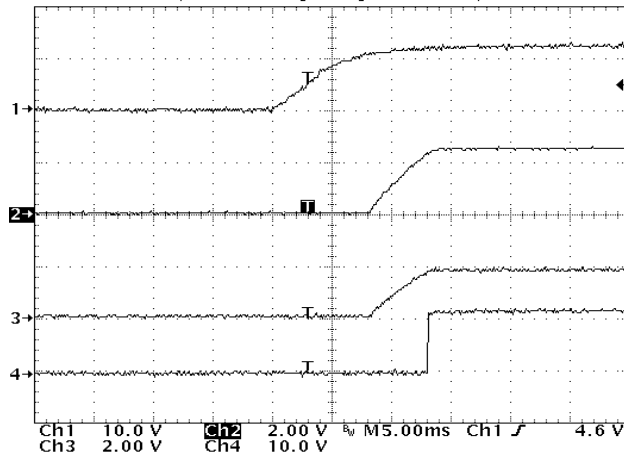

Figure 34 - Power Good Signal
 Ch1: Input Supply, Ch2: 2.5V Output, Ch3: 1.8V Output, Ch4 : Power Good Signal

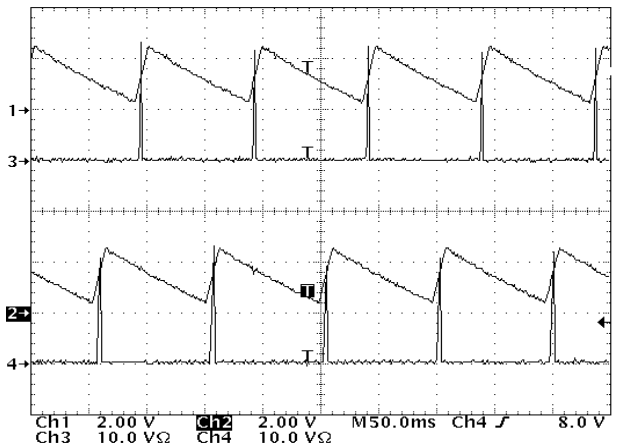

Figure 35 - Short Circuit Condition (Hiccup Mode).
 Ch1: SS1 pin, Ch2: SS2 pin, Ch3 and Ch4 : Inductor Currents
 Ch3:ch4: 10A/div

TYPICAL APPLICATION

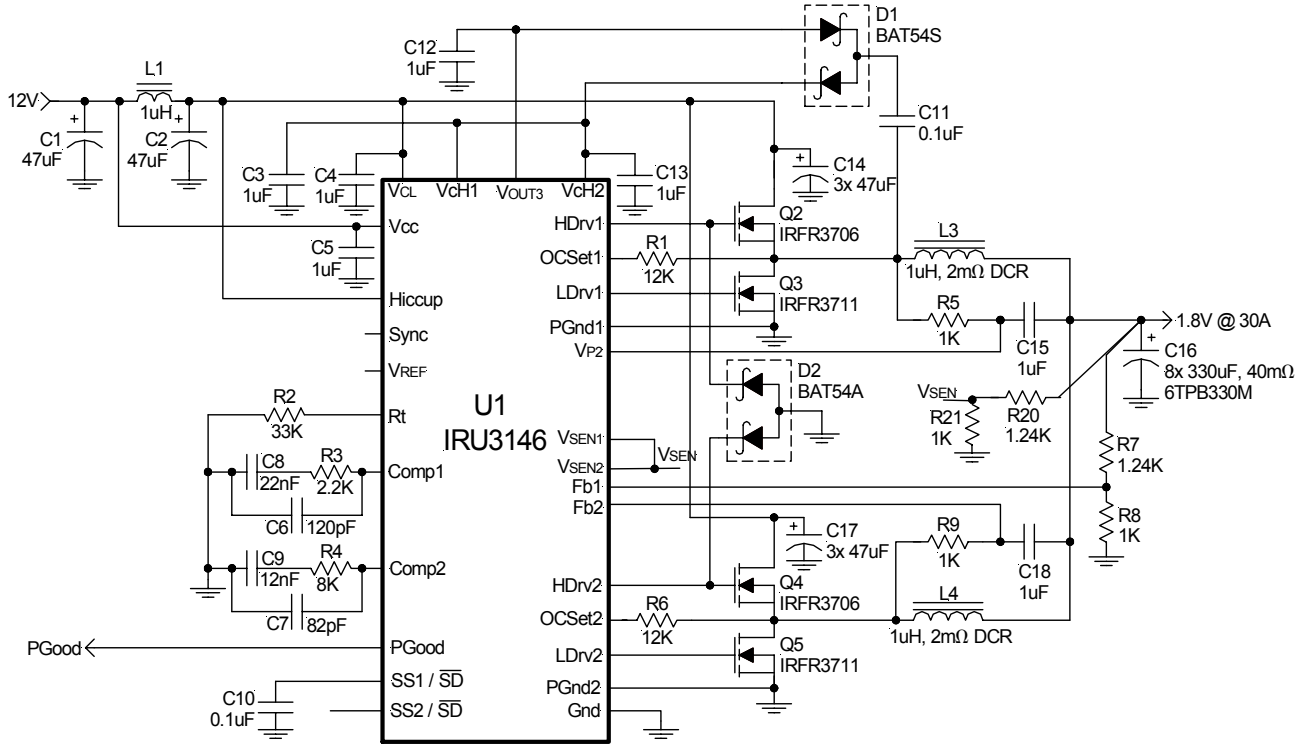

Figure 36 - 2-phase operation with inductor current sensing.
 12V to 1.8V @ 30A output

TYPICAL APPLICATION

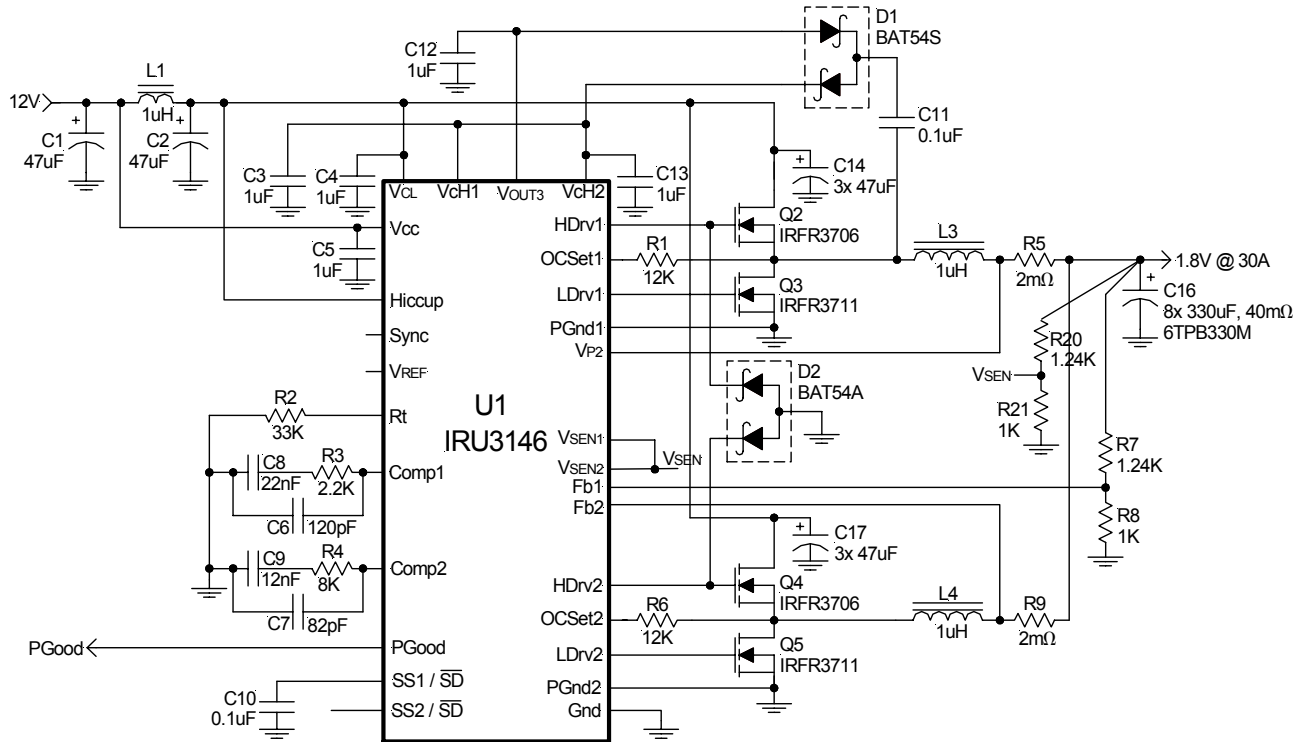

Figure 37 - 2-phase operation with resistor current sensing.
 12V to 1.8V @ 30A output

TYPICAL APPLICATION

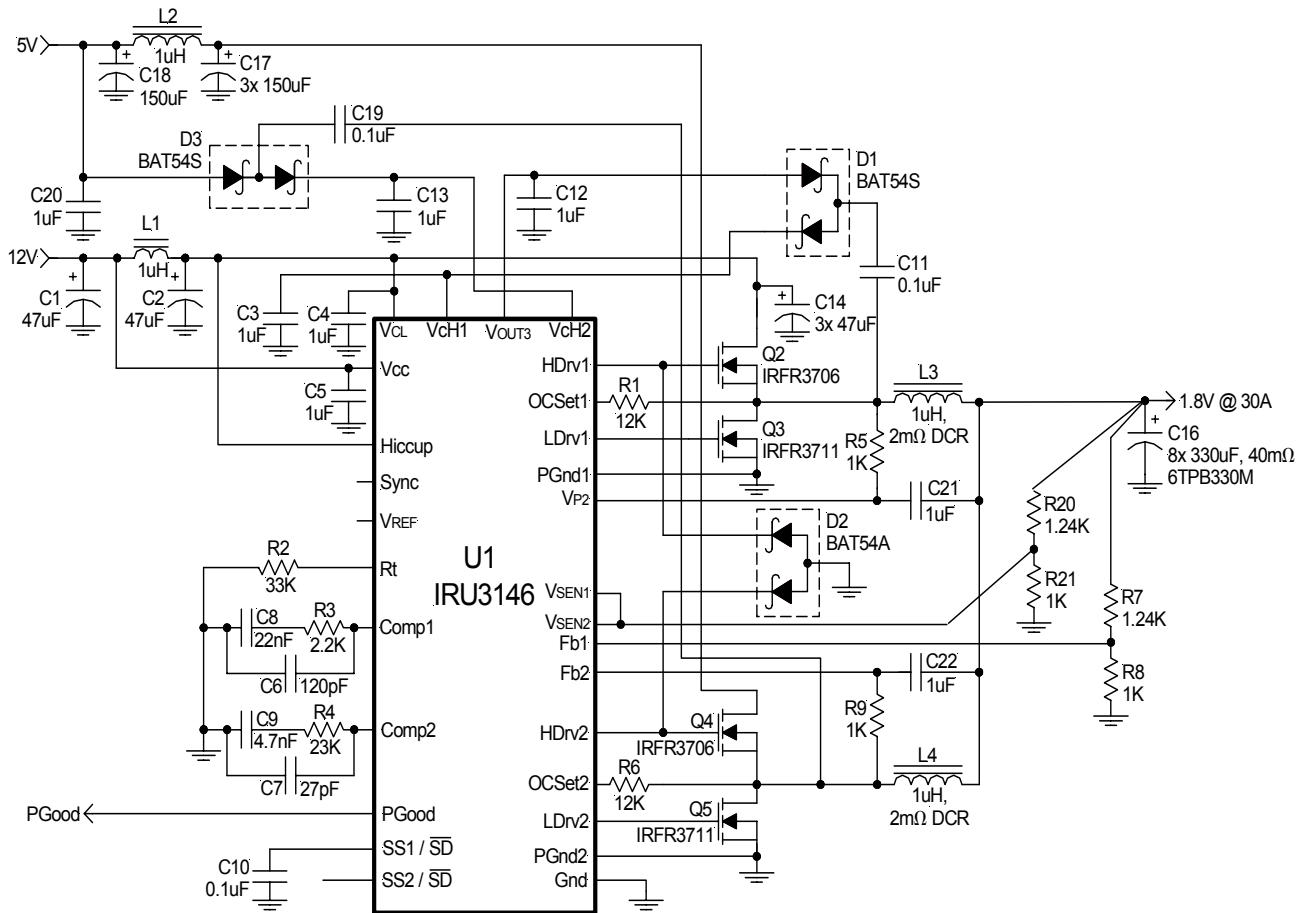

Figure 38 - Typical application of IRU3146 using 5V and 12V supplies to generate single output voltage. 1.8V @ 30A using inductor sensing.

TYPICAL APPLICATION

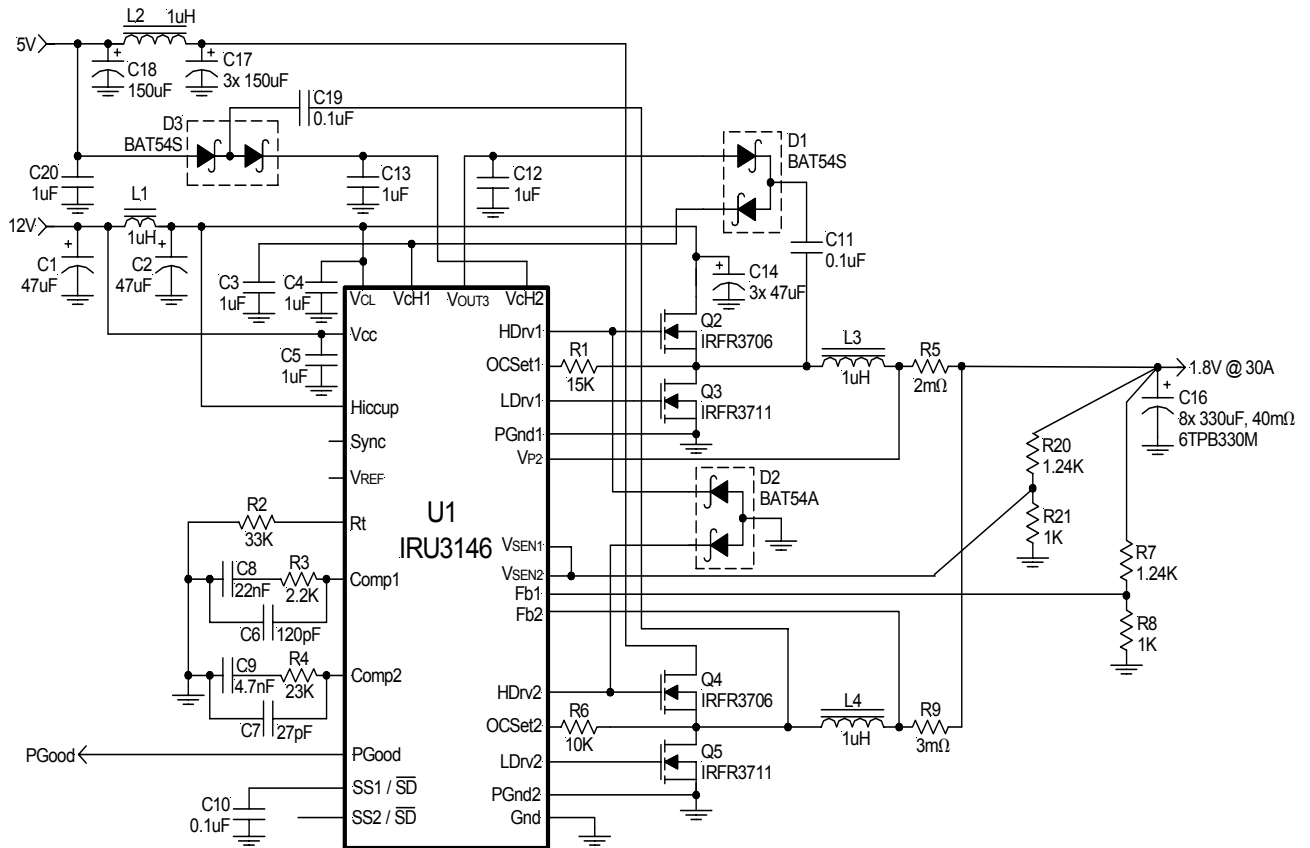

Figure 39 - Typical application of IRU3146.
 1.8V @ 30A output with 5V and 12V input and different input current setting.
 (5V @ 5A and 12V @ 3A)

TYPICAL APPLICATION

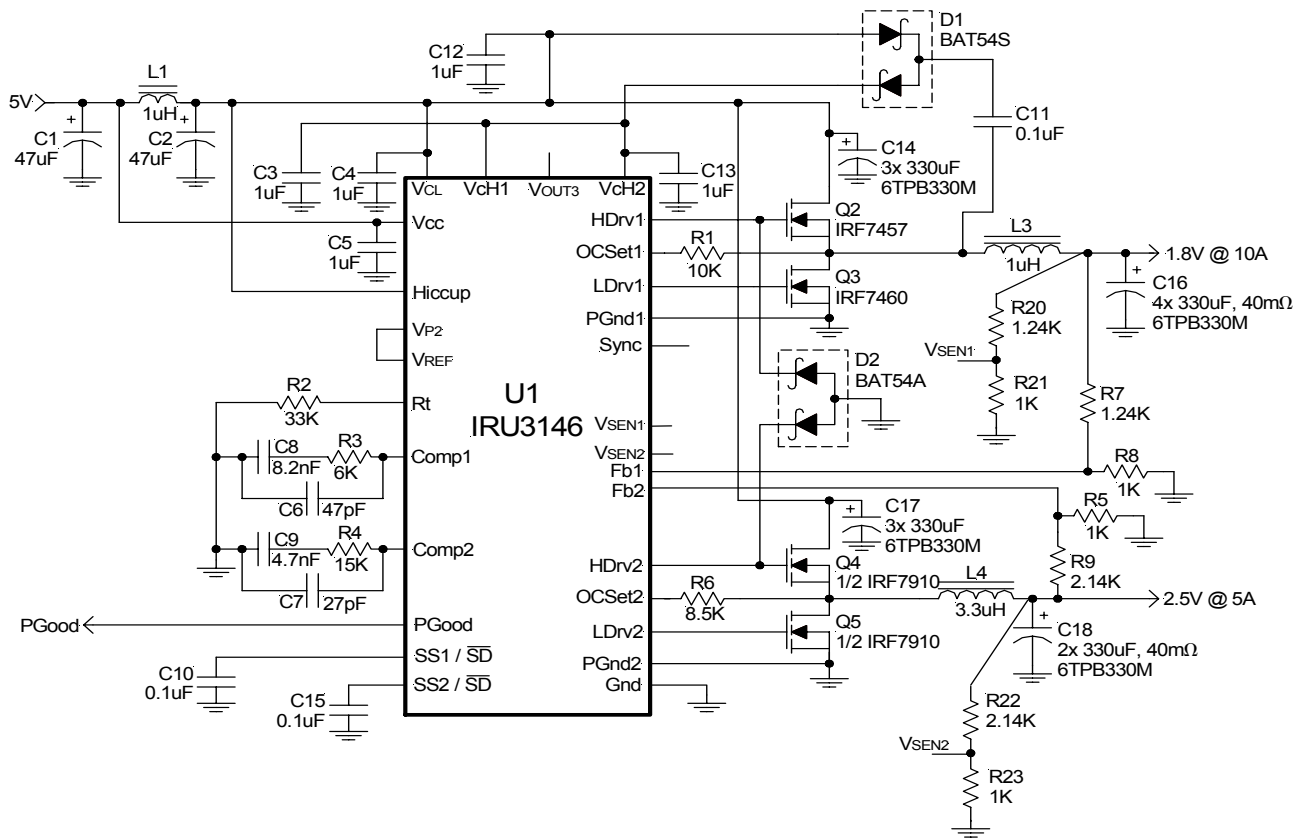

Figure 40 - Single 5V input and two independent outputs.

TYPICAL APPLICATION

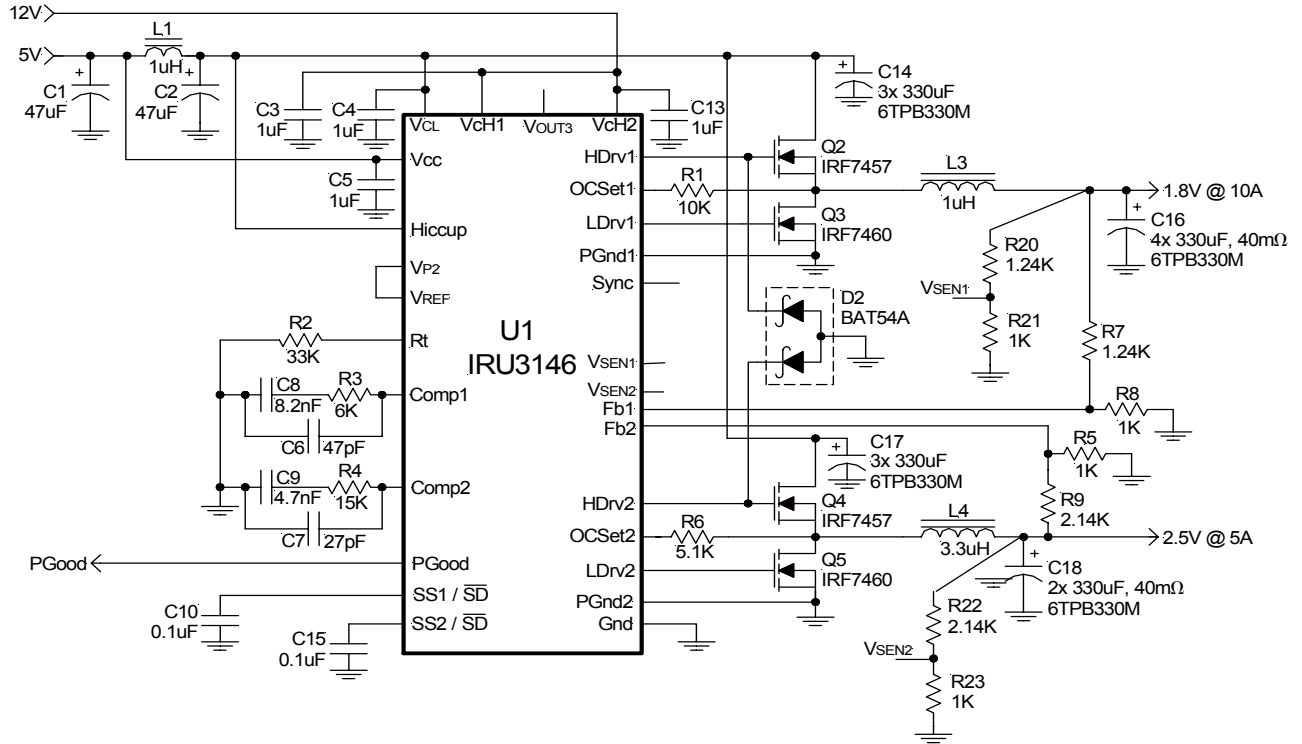

Figure 41 - Typical application of IRU3146.
 5V input, 12V drive and two independent outputs.

TYPICAL APPLICATION

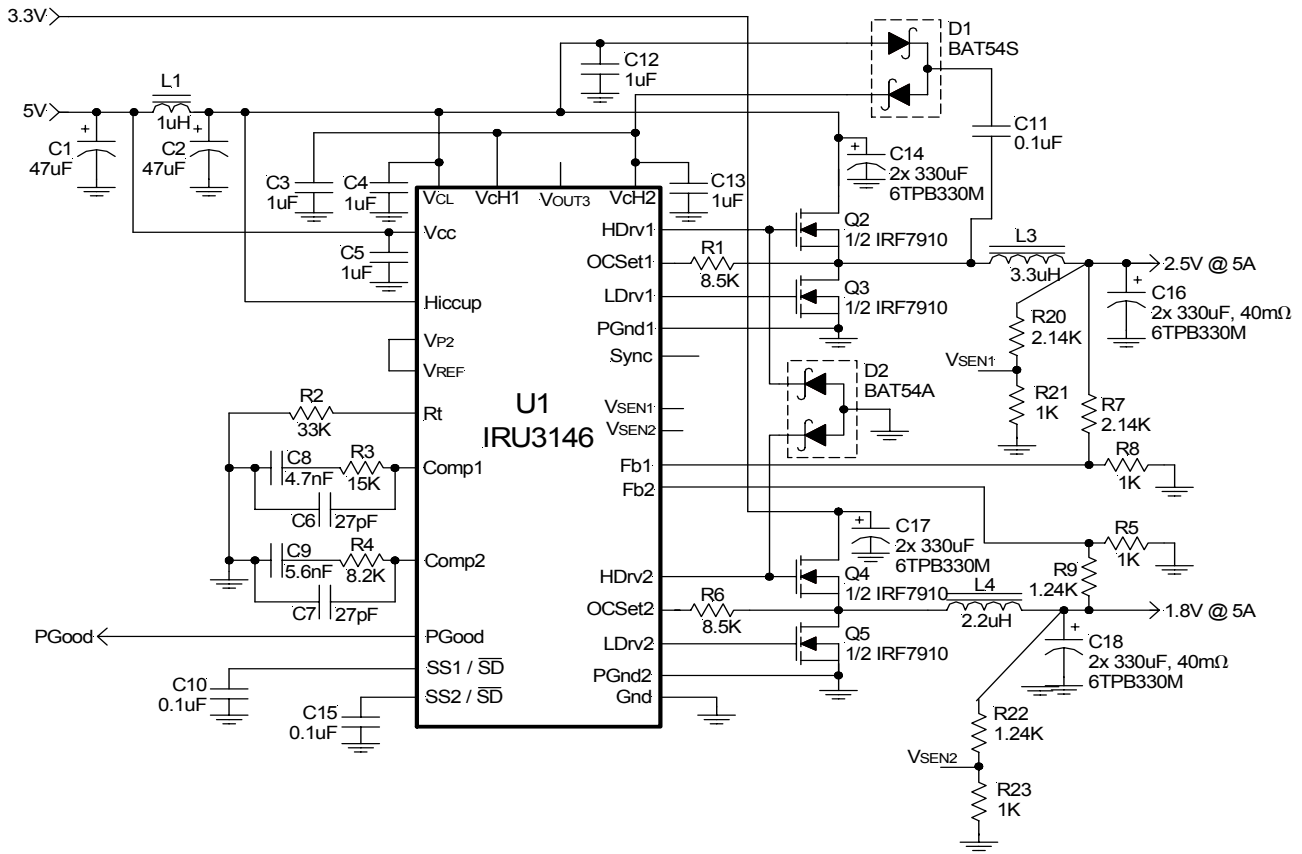
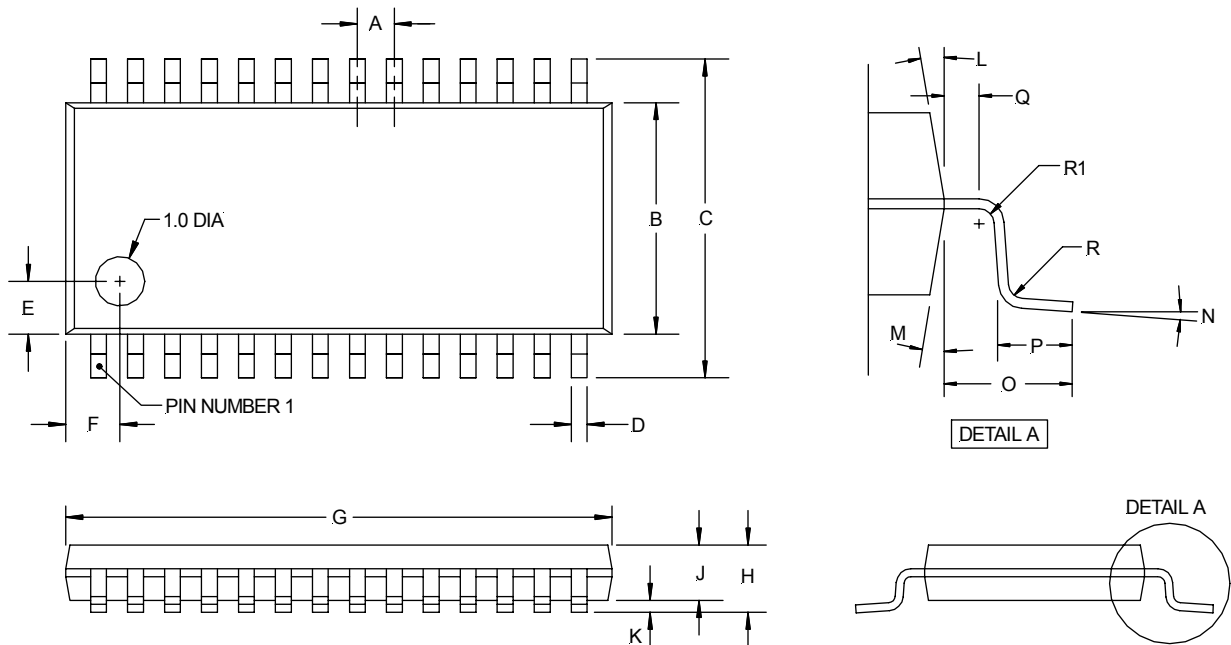

Figure 42 - Typical application of IRU3146.
5V to 2.5V and 3.3V to 1.8V inputs and two independent outputs.

**(F) TSSOP Package
 28-Pin**



SYMBOL	28-PIN		
	DESIG	MIN	NOM
A	0.65 BSC		
B	4.30	4.40	4.50
C	6.40 BSC		
D	0.19	---	0.30
E	1.00		
F	1.00		
G	9.60	9.70	9.80
H	---	---	1.10
J	0.85	0.90	0.95
K	0.05	---	0.15
L	12° REF		
M	12° REF		
N	0°	---	8°
O	1.00 REF		
P	0.50	0.60	0.75
Q	0.20		
R	0.09	---	---
R1	0.09	---	---

NOTE: ALL MEASUREMENTS ARE IN MILLIMETERS.

PACKAGE SHIPMENT METHOD

PKG DESIG	PACKAGE DESCRIPTION	PIN COUNT	PARTS PER TUBE	PARTS PER REEL	T & R Orientation
F	TSSOP	28	50	2500	Fig A

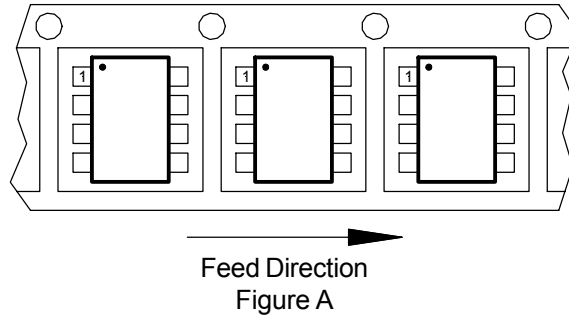

This product has been designed and qualified for the Industrial market.