

SEATING TOOL	BACKPLANE HEADER	
	POSITION	ROWS
91312-1	50	10
91312-2	100	
91313-1	30	6
91313-2	60	

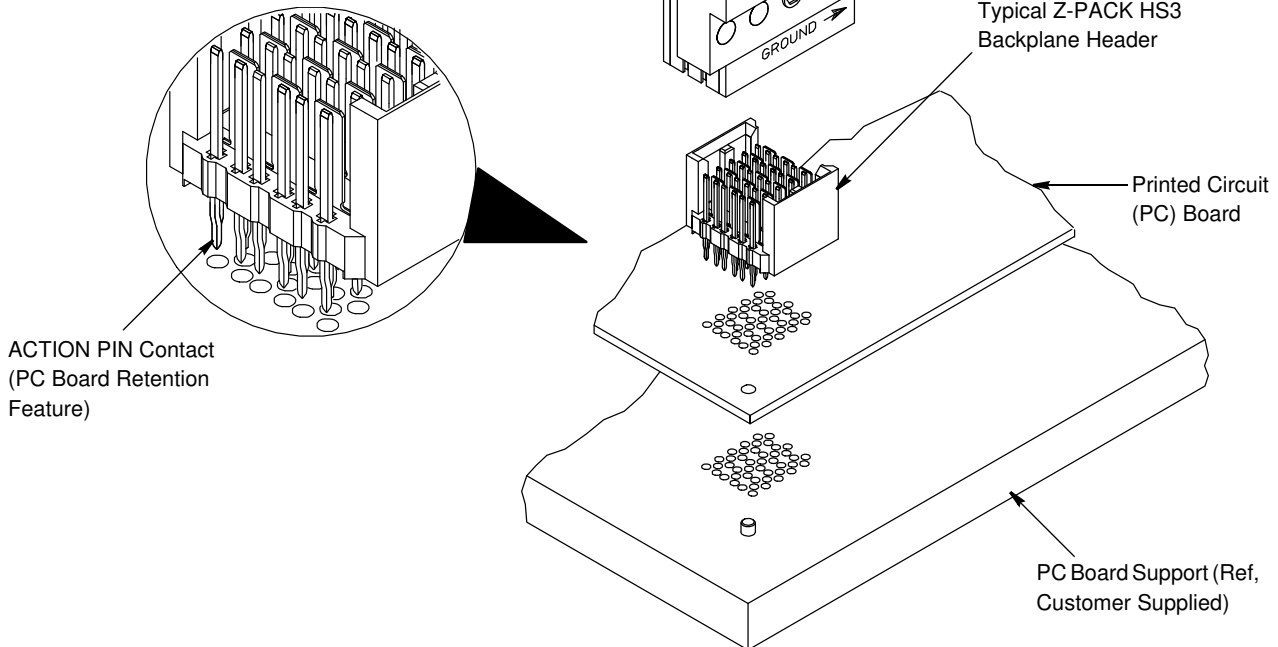
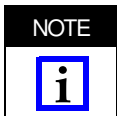

Figure 1

1. INTRODUCTION

Seating Tools 91312-[] and 91313-[] are used to seat Z-PACK HS3 backplane headers with ACTION PIN contacts to allow solderless pc board installation.



All dimensions on this document are in metric units [with U.S. customary units in brackets].

Read these instructions and understand them before using the seating tool.

Reasons for reissue of this instruction sheet are provided in Section 7, REVISION SUMMARY.

2. DESCRIPTION

Each seating tool is an assembly of plates, bars, and an adapter to seat the different sizes of the backplane headers. Figure 1 lists a cross-reference of the backplane header size to the seating tool part number to be used.

During seating, the seating tool sits inside the header housing engaging the housing floor and contact shoulders, preventing the contacts from pushing out of the housing.

3. REQUIREMENTS

3.1. Application Tooling

Power for the seating tool must be provided by an application tool (with a ram) capable of supplying a downward force of 89 N [20 lb] per contact.

Manual Electric Servo Presses (CMP 6T) 1585699-8 and (CMP 12T) 1585698-8, and Bench Top Electric Servo Press (CBP 5T) 1585696-9 are available for this seating tool.

For information on the presses, visit the press-fit assembly equipment website at <http://tooling.te.com/pressfit.asp>.

3.2. PC Board Support Fixture (Customer Supplied)

A pc board support must be used to provide proper support for the pc board and alignment of the seating tool to the header, and to protect the pc board and header contacts from damage. Design a pc board support fixture using the recommendations in Instruction Sheet 408-6927.

4. SEATING

1. Set the seating height to the dimension shown in Figure 2 (applicator shut height will equal the seating height PLUS the combined thicknesses of the pc board and pc board support).
2. Position the header onto pc board so that the header contact posts are properly aligned with the holes in the pc board and pc board support.
3. Insert the header onto the pc board until the post sections of the contacts are resting securely on, but have not fully entered, the pc board.
4. Position the appropriate seating tool into the header, making sure that the seating tool is bottomed on the housing floor.

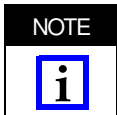

For Seating Tools -1 (not keyed), make sure that the grounding arrow is pointing toward the end row of ground blades of the header.

5. Center the seating tool and header under the applicator ram of the applicator; slowly lower the ram until it just meets the seating tool. Verify the alignment of the pc board support, pc board, header, and seating tool.



Damage to the pc board, seating tool, or header may occur if the wrong size seating tool is used, the seating height is improperly set, the grounding arrow (for Seating Tools -1) is oriented incorrectly, or the seating tool is not properly seated in the header before cycling the ram.

6. Cycle the applicator. Check the header for proper seating using the requirements in the Application Specification 114-13020.

7. Remove the pc board with the seated header or reposition the pc board and pc board support to seat additional headers.



Do not use damaged or defective headers.

5. MAINTENANCE AND INSPECTION

5.1. Initial Inspection

Each seating tool is assembled and inspected before shipment. It is recommended that the seating tool be inspected using Figure 3 immediately upon arrival to ensure that it has not been damaged during shipment.

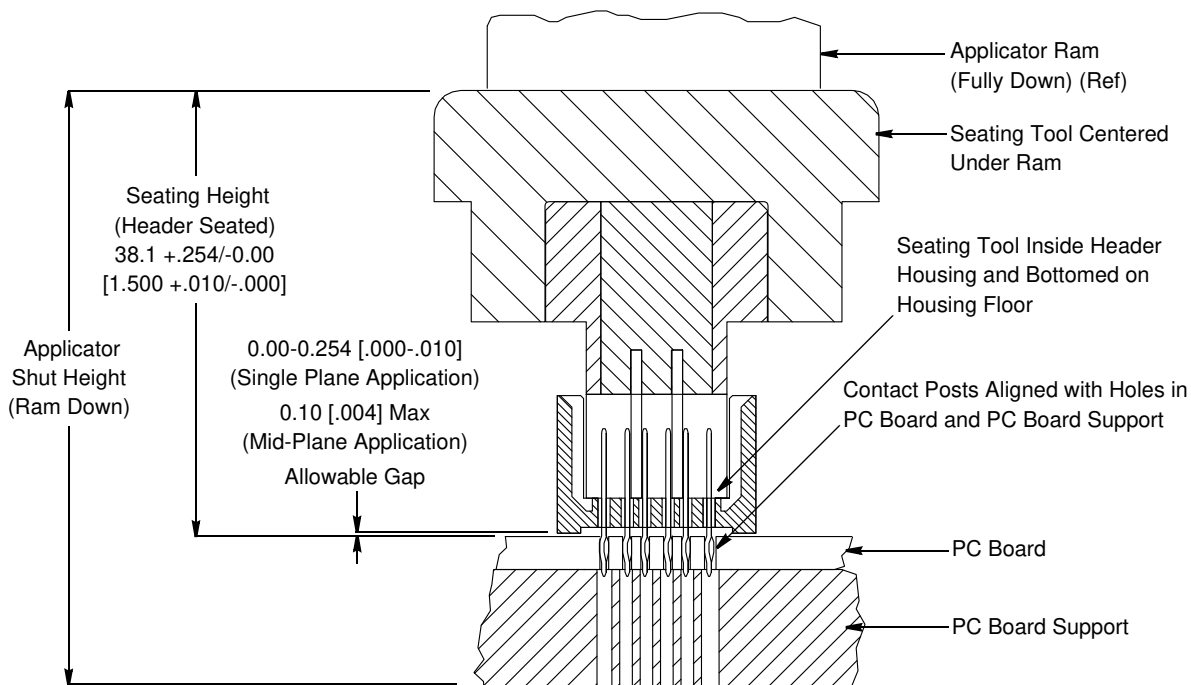

Figure 2

5.2. Daily Maintenance

It is recommended that each operator be made aware of, and responsible for, the following steps of daily maintenance:

1. Remove dust, moisture, and other contaminants with a clean, soft brush, or lint-free cloth. Do NOT use objects that could damage the tool or any of its components.
2. Ensure that pins and screws are in place and secured.
3. When the seating tool is not in use, store it in a clean, dry area.

5.3. Periodic Inspection

Regular inspections should be performed by quality control personnel. A record of scheduled inspections should remain with the seating tool or be supplied to supervisory personnel responsible for the seating tool. The inspection frequency should be based on the amount of use, working conditions, operator training and skill, and established company standards.

6. REPLACEMENT AND REPAIR

The parts listed in Figure 3 are customer-replaceable. A complete inventory can be stocked and controlled to prevent lost time when replacement of parts is necessary. Order replacement parts through your Representative, or call 1-800-526-5142, or send a facsimile of your purchase order to 1-717-986-7605 or write to:

CUSTOMER SERVICE (038-035)
 TYCO ELECTRONICS CORPORATION
 PO BOX 3608
 HARRISBURG PA 17105-3608

For customer repair service, call 1-800-526-5136.

7. REVISION SUMMARY

Revisions to this instruction sheet include:

- Changed company name and logo
- Changed Paragraph 3.1
- Replaced reference to application specification
- Added gap for mid-plane application to Figure 2

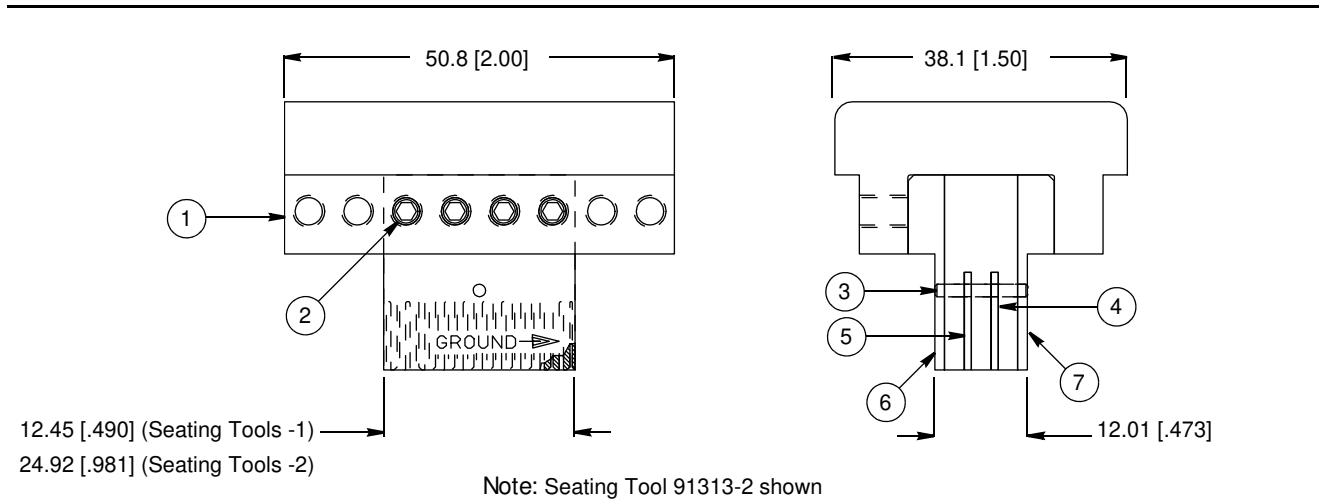

ITEM	PART NUMBER FOR SEATING TOOL				DESCRIPTION	QTY PER SEATING TOOL	
	10 Rows		6 Rows			91312-[]	91313-[]
	91312-1	91312-2	91313-1	91313-2			
1	1320190-1		1320190-1		Adapter	1	1
2	2-21012-8		2-21012-8		Socket Set Screw, 6-32x.19 in.	2 (-) 4 (-2)	2 (-) 4 (-2)
3	1-21028-0		21028-6		Slotted Spring Pin	1	1
4	1320192-1	1320192-2	1320193-1	1320193-2	Signal Pin Bar	1	1
5	1320194-1	1320194-2	1320194-1	1320194-2	Ground Pin Drive Bar	4	2
6	1320195-1	—	1320196-1	1320196-2	Side Plate	2	2
	—	1320195-2	—	—	Side Plate	1	—
7	—	1583844-1	—	1583646-1	Side Plate, Keyed	1	1

Figure 3