

A 90-3144

RAW MAT. SPEC. WITH
PART NO. AND AMOUNT REQ'D.

*.068 X .035" DEEP KEYWAY.
.071*

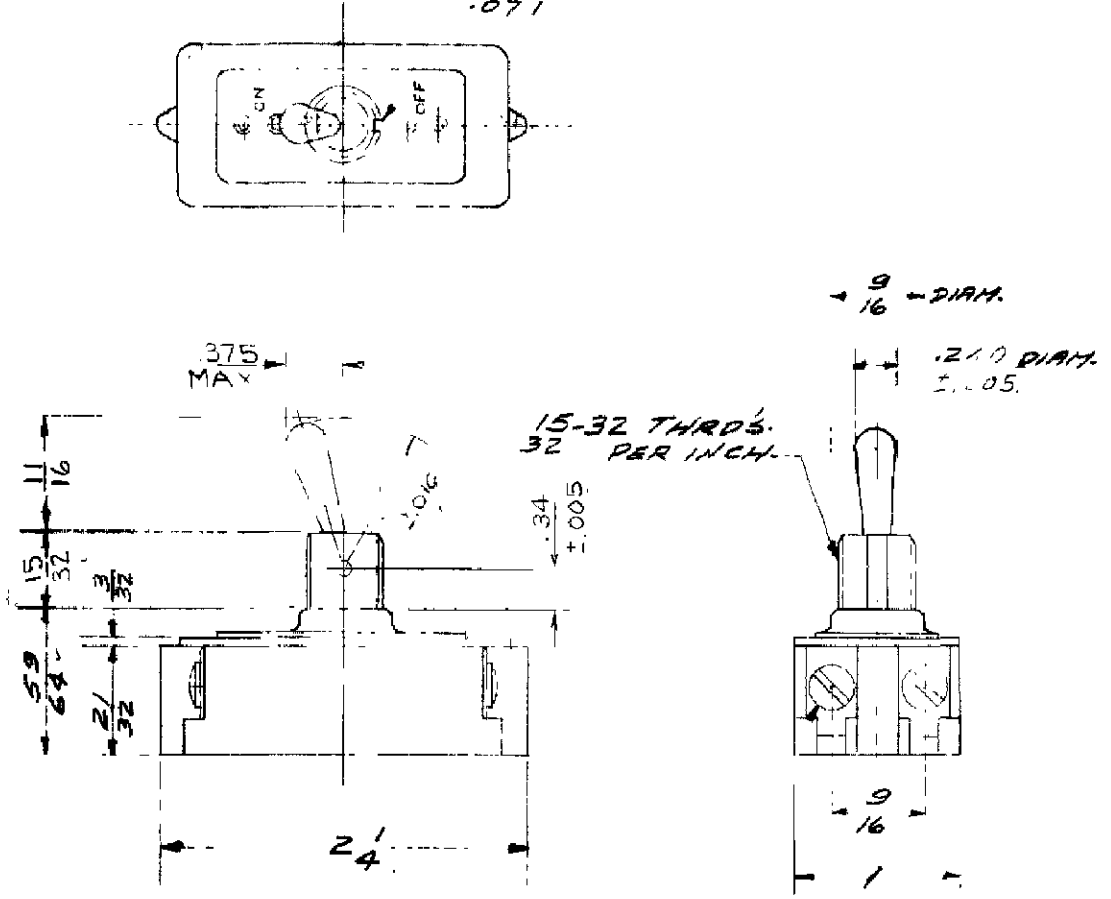

*A-#6-32 BINDING—
HEAD SCREWS 1/4" LONG*

BULLETIN
DIMENSIONS FOR 10 AMP. 250 V. ONE HOLE MTG. TOOL HANDLE SM.

A	G.F.L.	G.G.	2-8 62	DR R. ARTIN	3-30 -61	FIRST ASSEM. WHERE LISTED A90-3143
B				CHK L. SOTO 2/3/61		SUP'S. NON-INTERCHANGEABLE
C				AP J.E. Ranganis 4/4/61		SUP'D BY NON-INTERCHANGEABLE
D						SURFACE COATING
E						STANDARD TOLERANCES 50-275 APPLY TO DIMENSIONS SCALE 1"=1"
F						ORDER NO.
CUTLER-HAMMER, INC. MILWAUKEE NEW YORK				8 23 LI 57A		A 90-3144

NOTES:

1. SCREWS, WASHER AND HEX NUTS SHIPPED UNASSEMBLED.

$.072^{+.003}_{-.004} \times .035$ DEEP KEYWAY

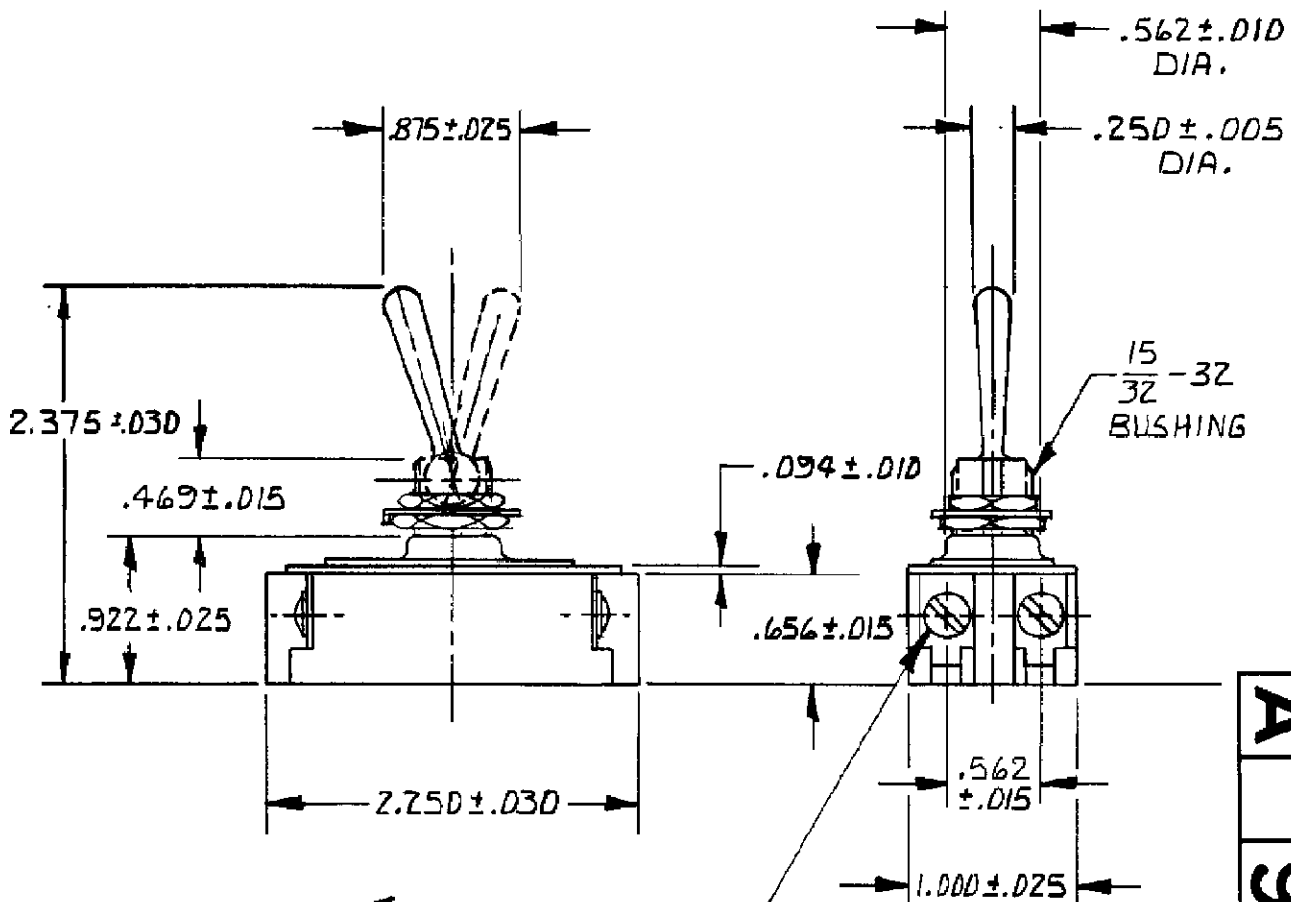
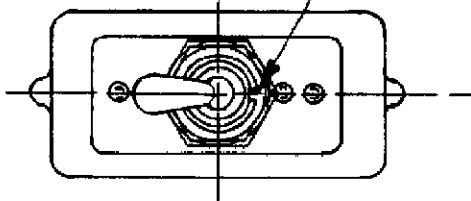

15
32 - 32
BUSHING

#6 - 32 BINDING
HEAD SCREWS
.250 LONG
QUANTITY OF 4



TITLE DIMENSIONS FOR 10-20A TOGGLE WITH LEVER SEAL

ORDER NO. 910DN 76

BASIC SPECS. SUMMARY

A		DR. G. STORY	12/1/84	APP. <i>[Signature]</i> 12/1/84
B		CHK. C. Maschino	12/1/84	FIRST ASSEM. WHERE LISTED
C		Cutler-Hammer F.T.N. Electrical/Electronic Control		

A 90-12054

FORM 80B

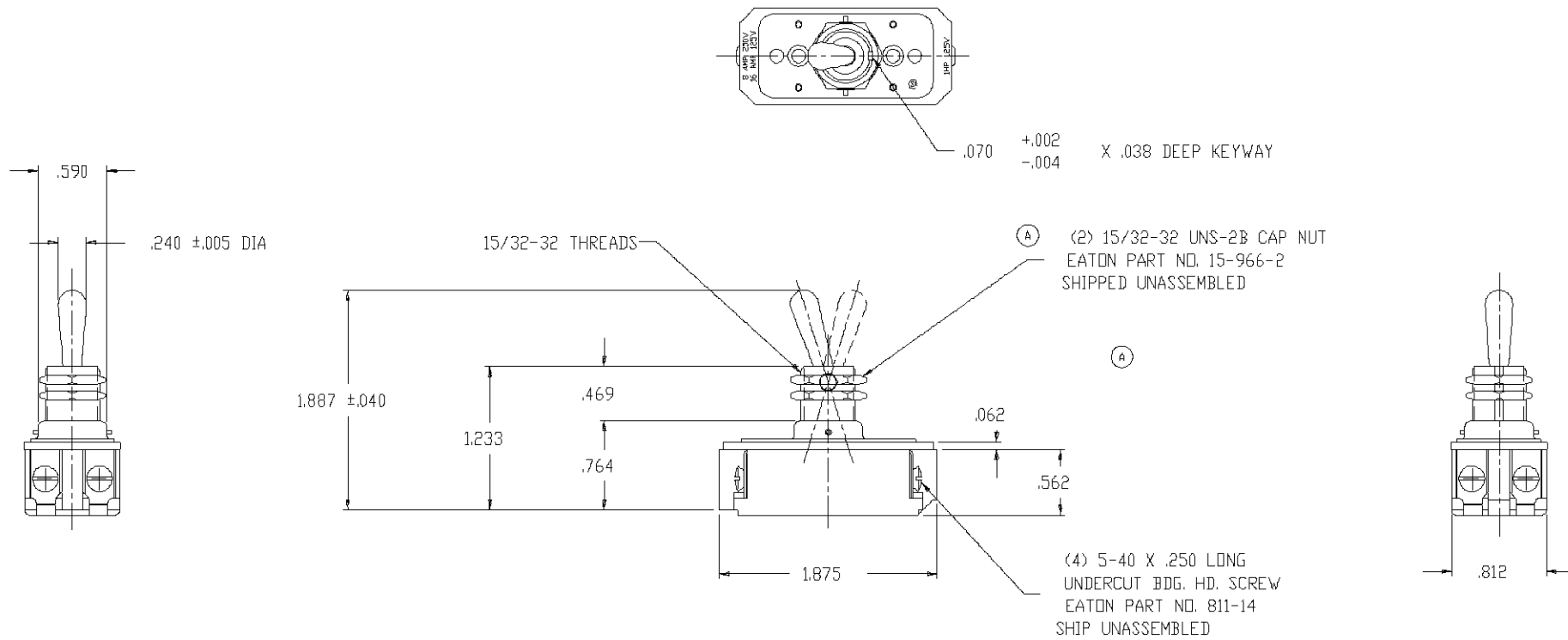

NOTE:
1. UNLESS OTHERWISE SPECIFIED ALL TOLERANCES TO BE $\pm .016$.

ORDER NO. 93719990

A	REMOVED 15-192 NUT NOTE. ADDED "(2)" TO 15-966-2 NUT NOTE.	6/29/94	D				
B		93719990	E				
C			F				



TITLE: DIM DWG FOR 8910K223			
DR. W. HANSON	2/1/92	SURFACE COATING	FIRST ASSEM. WHERE LISTED 8910K223
CHK. W. LEONARD	2/3/92	SCALE	SUP'S
APP. M.R. DUMMER	2/3/92	DO NOT SCALE DRAWING	SUP'D BY