

LMR-240

RG-8/X

REV.	DATE	ECR NO.	DESCRIPTION
NC	10/08/08	XXXXXX	INITIAL RELEASE
A	12/05/99	XXXXXX	UPDATE DRAWING
B	01/21/07	XXXXXX	UPDATE DRAWING FORMAT
C	04/07/08	XXXXXX	REVISE BODY, FERRULE PLATING TO NEXCOTE
D	12/02/13	2663	ADD SPACER, ADD TABLE A AND MODIFY STRIPPING DIMENSIONS ADD ELECTRICAL/MECHANICAL NOTES, UPDATE DRAWING FORMAT

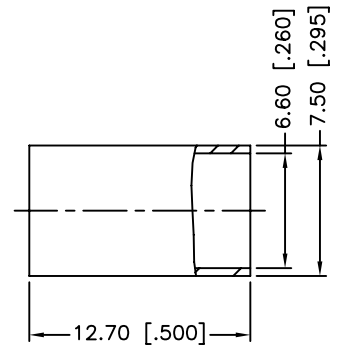
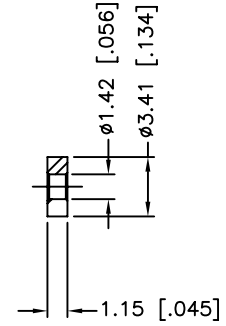
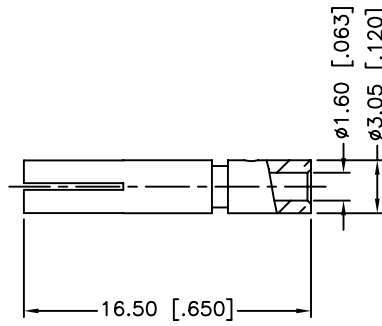
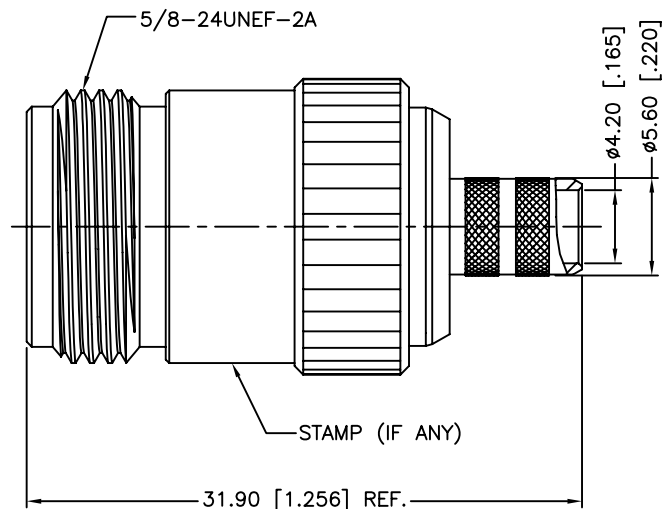
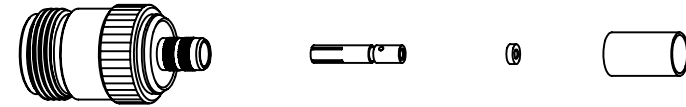

1. IMPEDANCE: 50 OHM
2. FREQUENCY RANGE: 0-11 GHZ
3. DIELECTRIC WITHSTANDING VOLTAGE: 2500 VRMS, MIN.
4. DURABILITY: 500 CYCLES MIN.
5. TEMPERATURE RANGE: -65°C TO +165°C
6. CRIMPED FERRULE
HEX. CRIMP SIZE .255"
7. CRIMPED CONTACT PIN
HEX. CRIMP SIZE .100"
8. SEE TABLE A FOR RECOMMENDED
CABLE STRIPPING DIMENSIONS

TABLE A				
CABLE TYPE	DIMENSION A	DIMENSION B	DIMENSION C	SPACER REQUIRED
LMR-240	5.15 [.203]	7.70 [.303]	16.00 [.630]	YES
RG-8/X	4.00 [.157]	7.70 [.303]	16.00 [.630]	NO

DESCRIPTION	MATERIAL	FINISH	QTY
6 FERRULE	BRASS	NEXCOTE	1
5 SPACER	PTFE	NATURAL	1
4 CONTACT PIN	PHOSPHOR BRONZE	GOLD	1
3 BARREL	BRASS	NEXCOTE	1
2 INSULATOR	PTFE	NATURAL	1
1 BODY	BRASS	NEXCOTE	1

UNLESS OTHERWISE SPECIFIED DIMENSIONS ARE IN MILLIMETERS. DIMENSIONS IN [] ARE IN INCHES AND FOR CUSTOMER REFERENCE ONLY.
UNLESS OTHERWISE SPECIFIED
TOLERANCES FOR MILLIMETERS ARE:
<0.5 ± 0.05mm
0.5 - 6mm ± 0.10mm
6 - 30mm ± 0.20mm
30 - 120mm ± 0.30mm
ANGLES ± 1°
UNLESS OTHERWISE SPECIFIED
TOLERANCES FOR INCHES ARE:
<.020 ± 0.002"
.020 - .236 ± 0.004"
.236 - 1.180 ± 0.007"
1.180 - 4.724 ± 0.012"
ANGLES ± 1°
DO NOT SCALE DRAWING

APPROVALS		DATE
DRAWN	M.ZHANG	12/02/13
CHECKED		
ISSUED		
SHEET	1 OF 1	
CAD FILE	C:/CONNEX/172148.DWG	

Amphenol Connex

PART DESCRIPTION
**N CRIMP JACK
(FOR RG-8/X, LMR-240 CABLE)**

PART NO.
172148

DWG. NO.	172148.DWG	REV.	D	SIZE	A	SCALE	NA
----------	------------	------	---	------	---	-------	----