



Typical unit

**FEATURES**

- 120W DC-DC converter(216W peak)
- 12V main output and 5V,1A Aux output
- Low ripple and Low surge output
- Input Voltage: 36V-75V
- Working Temperature: -20 - +85°C
- High Efficiency up to 95%
- Compact Size 86.5x122.4x35.4mm
- Small and Lightweight (160g)
- IP56 compliance
- Vibration-proof case design
- Over Temperature Protection
- Built-in Over-current and short circuit protection circuit
- RoHS Compliant

**DESCRIPTION**

MYPMA01218RCF-CCB is an ultra-efficient, non-isolated DC-DC converter providing 216W power at 12V output. It also provides a 5V/1A non-isolated auxiliary output. The small and lightweight converter is packaged in a plastic case conforming to IP56 standard.

Originally designed for lighting application on the E-motorcycle, E-scooter, E-tricycle and E-super small car using non-automotive grade components, the converter is suitable for a wide variety of industrial and commercial applications.

**Connection Diagram**

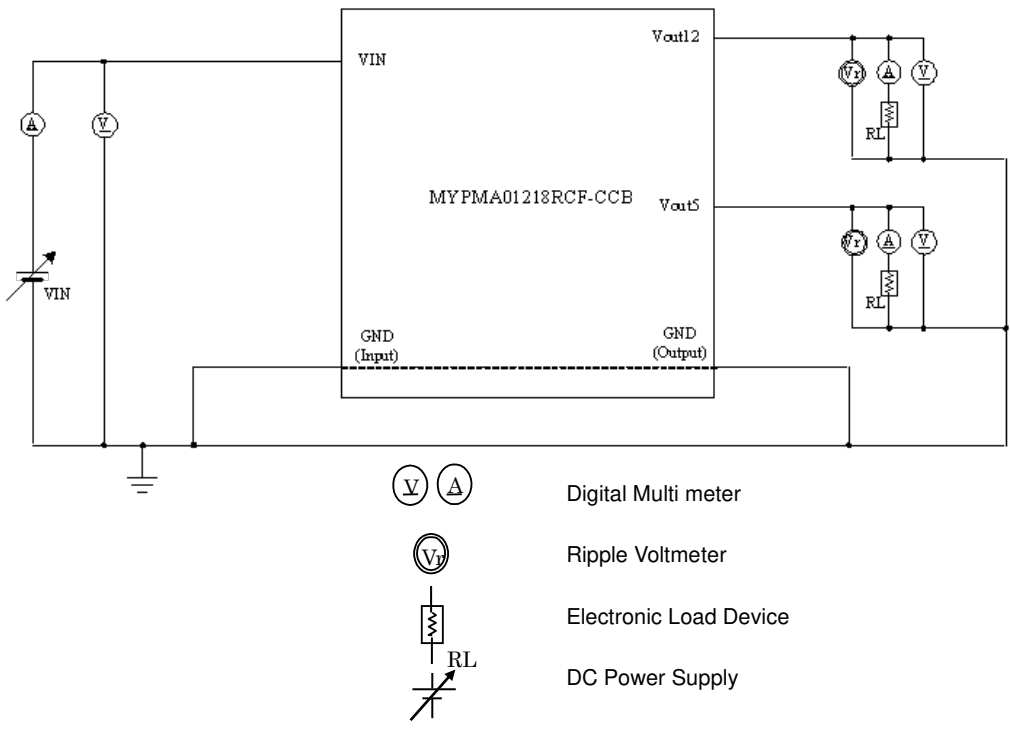

GND terminals are connected inside of DC-DC converter. However, please make sure that they are to be connected outside in order to prevent DC-DC converter from malfunction by noise.

**Performance Specifications Summary**

**Non-isolated type**

Model Number	Output	Output							Input		Efficiency		
		Vout (Volts)	Iout(Amps)			Power (Watts)	Ripple (mVp-p) (Max.)	Regulation (Max)**		Vin Nom. (Volts)	Range** (Volts)	Min.	Typ.
			(Min)	(Max)	(Peak)			Line	Load				
MYPMA01218 RCF-CCB	Main	12	2	10※	18	120	540	±5%	±5%	48	36-75	90%	95%
	Aux	5	0.2	1	1.2	5	120						

※When Iout(Aux)=1.0A that Iout(Main)=8.0A(Max)

@Ta=25°C

**Functional Specifications**

Input	
Input Voltage Range	See Performance specification
Isolation	Not isolated. Input and output Commons are internally connected.
Start-Up Voltage	29.9Vdc
Undervoltage Shutdown	27.3Vdc
Overvoltage Shutdown	None
Internal Input Filter Type	Capacitive
Reverse Polarity Protection	None, install external fuse.
Recommended External Fuse	20A
Shutdown Mode	UVLO
Remote On/Off Control	None
Output	
Output Voltage**	See Performance Specification
Ripple/Noise	See Performance Specification
Line/Load Regulation	See Performance Specification
DC Load Output Current	See Performance Specification
Current Limit Inception	20A
Efficiency	See Performance Specification
Short Circuit Protection	Built-in
Protection Method	Hiccup auto-recovery upon overload removal.
Short Circuit Duration	Continuous, no damage (output shorted to ground).
Over Temperature Protection	Built-in
Protective Method	Autorecovery upon over temperature removal.
Over Temperature Duration	Continuous, no damage
Pre-bias Startup	Converter will start up if the external output voltage is less than Vnominal.
Dynamic Characteristics	
Start Up Time (Vin on to Vout regulated or On/Off to Vout)	< 100msecs
Switching Frequency	102kHz

Environmental	
Estimated life Expectancy for Electrolytic Capacitor (Note 1)	4 years or more
Operating Temperature Range with derating	-20 to +85°C
Storage Temperature Range	-30 to +85°C
Operating Humidity Range	+20 to +95%
Storage Humidity Range	+10 to +90%
Thermal Protection/Shutdown	+140°C
Physical	
Outline Dimensions	See Mechanical Specifications
Tightening torque	1.51Nm max. for each M5 screw
Weight	160g
Vibration	10G at 10-2000Hz, 4Hrs ×3 axis
Shock	40G at 100 bumps/6msec ×3 axis
Safety Standard UL60950/IEC 60950	No registered Number. However the enclosure is made from UL94V-0 equivalent materials.
International Protection Code IEC60529	IP-56, exclude connector.

**Specification Note:**

- (1) Rated load, ambient air temperature of 65°C. Surface temperature of a maximum of 95°C of the metal plate. 3 hours in operation per one day

Reliability test Specifications

Reliability Test	
High temperature load test	Expose 100hrs in +65°C±3°C with 48Vin.
High temperature high humidity load test	Expose 100hrs in +65°C±3°C/90%RH with 10A load and 48Vin.
ESD test	Expose condition A(r=1500Ω, C=100pF) on EIAJ ED-4701 method C-111.
Temperature cycling test	Expose 100 cycles in the following sequence..-40°C±3°C/30min->, Room temperature(+25°C)/10sec->+85°C±3°C/30min->Room temperature(+25°C)/10sec.

After above test, hold in the room temperature(+25°C) for 24hrs, then measure above parameters indicated (\*\*) in the above specification.

Typical Performance Data

Effeciency vs, Line Voltage and Load Current @Ta = +25°C  
(100% : Vout12=10A,Vout5=1A)

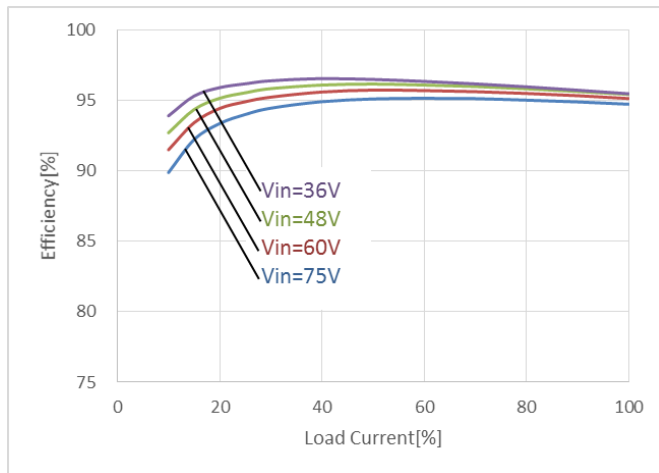

Maximum Current Temperature Derating at Sea Level (Vin=60V)  
(100% : Vout12=10A,Vout5=1A)

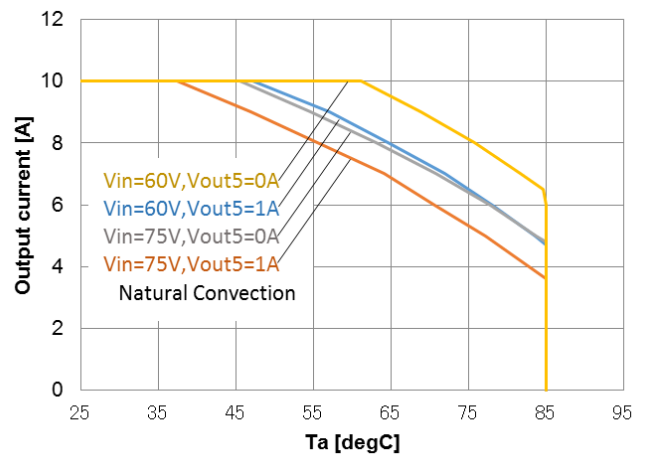

Output Ripple and Noise (Vin = 36V, Iout main = 8A, Iout aux = 1A, Cload = 0.1uF,  
Scope Bandwidth = 20MHz) Trace 1 = Vout main, Trace 2 = Vout aux

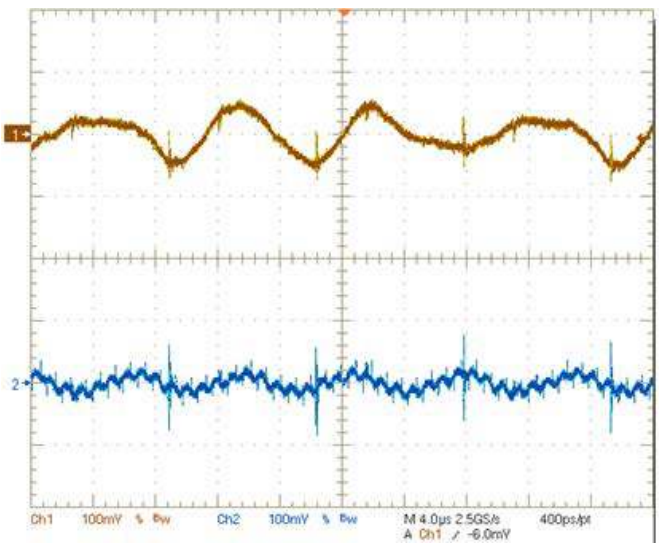

Turn On Delay (Vin = 36V, Iout main = 8A, Iout aux = 1A, Cload = 0.1uF)  
Trace1 = Vout main, Trace 2 = Vout aux, Trace 3 = Vin

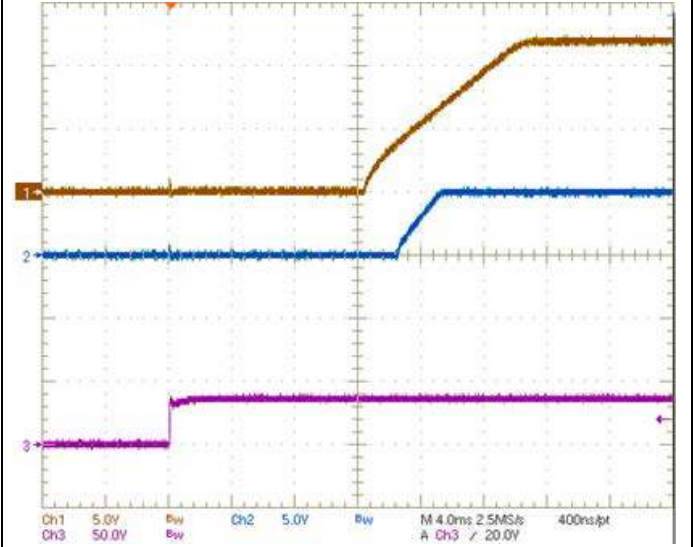

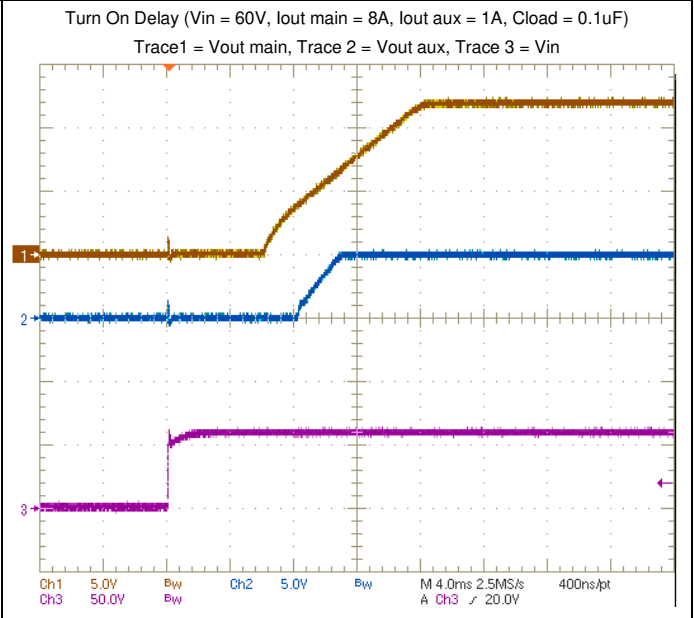
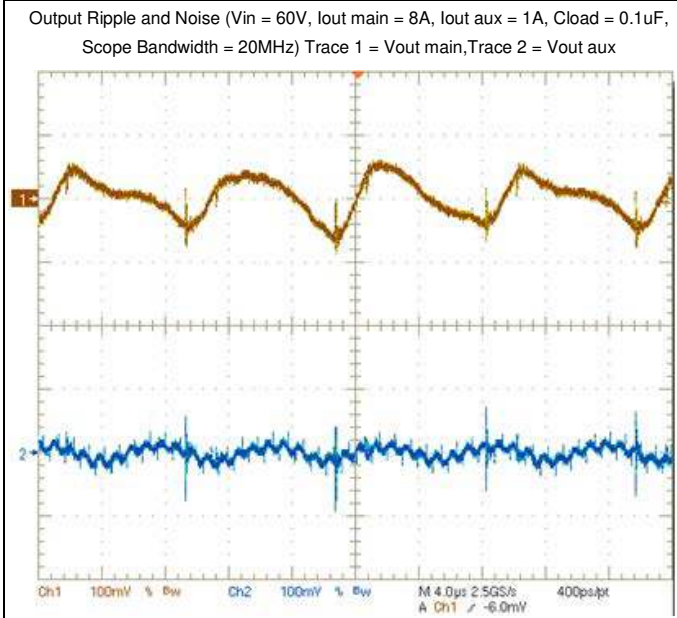
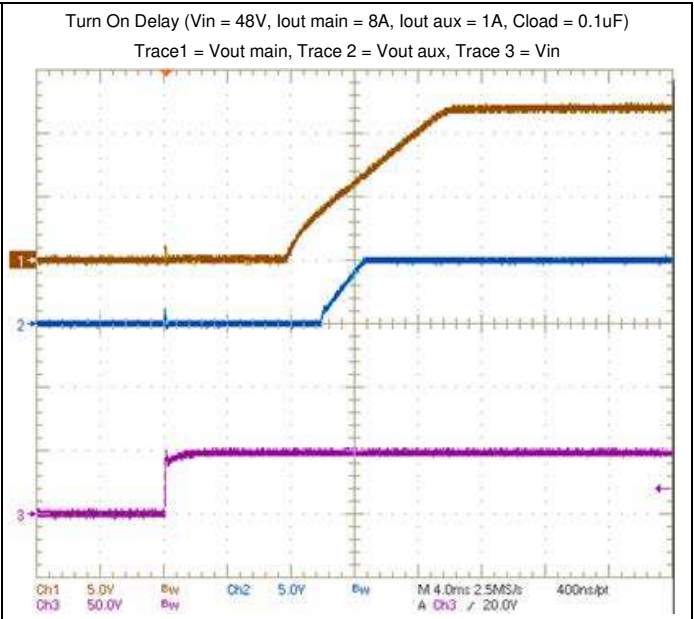
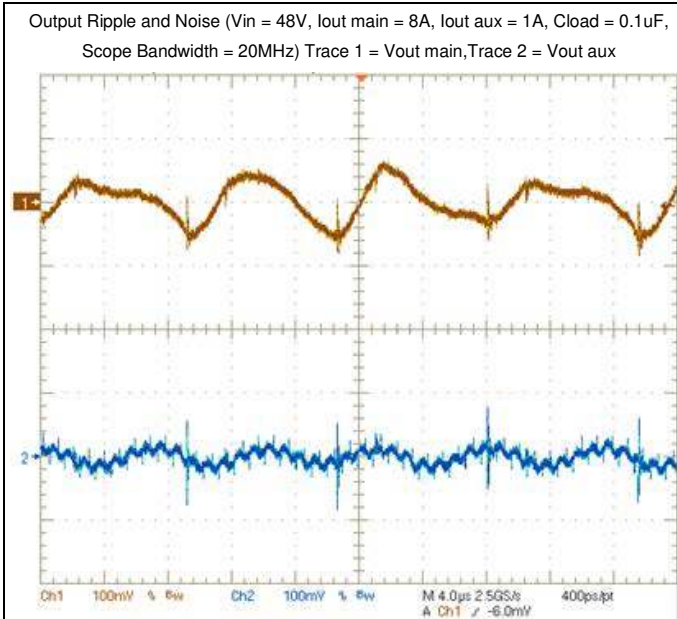

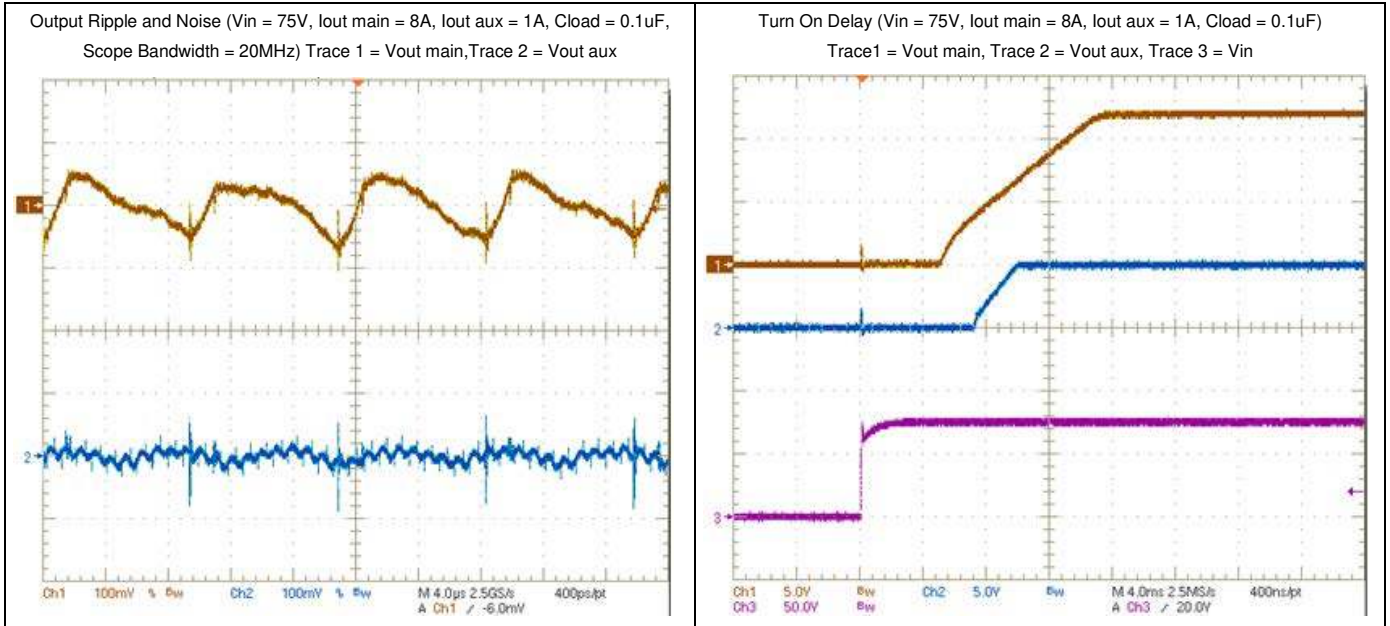

**Mechanical Specifications**

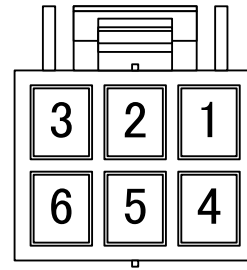
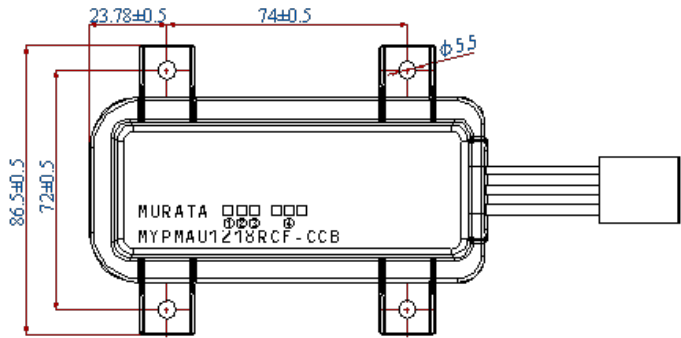

Recommended female connector :  
VLR-06V (JST)

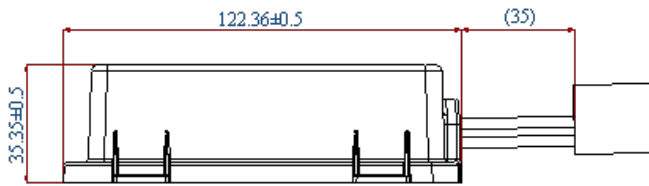

Input/output Connections P72		
Pad	Function	Wire Color
1	N.C.	-
2	Vout5	Yellow
3	Vout12	Orange
4	Vin	Red
5	GND(Input)	Black
6	GND(Output)	Blue

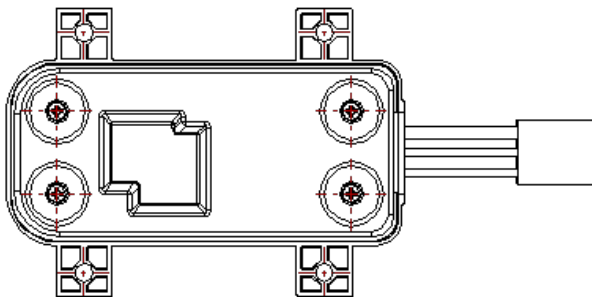

- The connector of the converter is not waterproof.
- Proper precautions should be taken to keep the converter water and dust free, to avoid a short-circuit.
- Frame should be assembled using M5 screws, with a maximum torque of 1.51Nm.
- Maximum allowable temperature on metal plate is 95°C.
- Do not expose this product to direct sunlight.

**Packaging Specification**

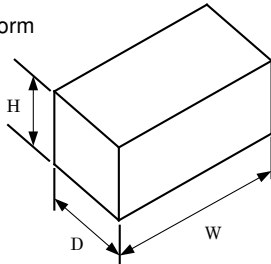
Item	Specification
Packaging form typical classification	Box
Dimensions of packaging form 	<p>W = 540 (mm)</p> <p>D = 355 (mm)</p> <p>H = 255 (mm)</p>
The number of products in a packaging form	35(pcs.)
Remark	Minimum order quantity is 105pcs. (3boxes * 35pcs/box. = 105pcs.)



## Functional Specifications

Please contact Murata Sales before using this product for the applications listed below. These are applications that require very high reliability of prevention of defects which might directly cause damage to third party's life, body, or property.

1. Aircraft equipment
2. Aerospace equipment
3. Undersea equipment
4. Power plant control equipment
5. Medical equipment
6. Transportation equipment (cars, buses, trucks, trains, ships, etc.)
7. Traffic signal equipment
8. Disaster prevention /crime prevention equipment
9. Data-processing equipment
10. Application of similar complexity and /or reliability

## Storage

Please store this product in an environment where the temperature/humidity is stable in the range 0 to 40°C/10 to 75%RH and no direct sunlight. Use the product within 6 months after delivery. Please avoid storage conditions where humidity and temperature change rapidly, as that may cause condensation on the product, which might degrade the quality of the product.

This product may rust after a long time (more than 1 year) storage. Please do not store the product environments that are dusty, in direct exposure to sea breeze, or in an atmosphere containing corrosive gas (Cl<sub>2</sub>, NH<sub>3</sub>, SO<sub>2</sub>, NOX and so on).

## Operational environment and operational conditions

### Operational environment

This product is not chemical-proof or rust-proof.

In order to prevent this product from leakage of electricity and/or abnormal temperature increase, do not use the product under the following circumstances:

- (1) in an atmosphere containing corrosive gas (Cl<sub>2</sub>, NH<sub>3</sub>, SO<sub>2</sub>, NOX and so on).
- (2) in a dusty place.
- (3) in a place exposed to direct sunlight.
- (4) in such a place where water splashes or in such a humid place where water condenses.
- (5) in a place exposed to sea breeze.
- (6) in any other places similar to the above (1)through (5).

### Operational conditions

Please use the product within specified values (power supply, temperature, input, output and load condition etc.). Input voltage drops for line impedance, so please make sure that input voltage is within specified values.

If the product is used over the specified values, it may damage the product, reduce the quality, and even if the products can endure the condition for short time, it may cause degradation of the reliability.

## Note prior to use

If you apply high static electricity, voltage higher than rated voltage or reverse voltage to the product, it may cause defects in the products or degrade the reliability.

Please avoid the following items:

1. Over rating power supply, reverse power supply or not-enough connection of input voltage and 0V(DC)line
  2. Electrostatic discharge by production line and/or operator
  3. Electrified product by electrostatic induction
- Do not subject product to excessive mechanical shock. If you drop the product on the floor it might cause a crack to the core of inductors and monolithic ceramic capacitors.
  - Also please pay attention to handling; the mounted parts can be dislodged if subjected to excessive force.
  - Input and output wiring cords should have slack so that they do not exert stress to the input/output connectors of the product. Subjecting the connectors to sustained stress may damage the product.

## Assembly

Assemble the frame by using M5 screws, with a torque of 1.51Nm [reference only]

## Transportation

If you transport the product, please pack it so that the package will not be damaged by mechanical vibration or mechanical shock, and please educate and guide the carrier to prevent rough handling.

If you transport the products overseas (in particular, by sea), it is expected that the transportation environment will be the worst, so please pack the products in a package that is mechanically strong, vibration-resistant, and humidity-resistant. The packaging of the products that Murata sells in Japan may not be suitable overseas transport. Please consult Murata Sales if you plan to use the standard Murata packaging of the products for transport to overseas.

## Note

1. Please make sure that the product has been evaluated and confirmed against your specifications when it is mounted to your product.
2. All the items and parameters in this product specification have been prescribed on the premise that our product is used for the purpose, under the conditions and in the environment agreed upon between you and us. You are requested not to use our product deviating from such agreement.
3. We consider it not appropriate to include other terms and conditions for transaction warranty in product specifications, drawings or other technical documents. Therefore, if your technical documents as above include such terms and conditions as warranty clause, product liability clause, or intellectual property infringement liability clause, we will not be able to accept such terms and conditions unless they are based on the governmental regulation or they are stated in a separate contract agreement.



This product is subject to the following [operating requirements](#) and the [Life and Safety Critical Application Sales Policy](#).  
Refer to: <https://power.murata.com/en/requirements>

Murata Manufacturing Co., Ltd makes no representation that the use of its products in the circuits described herein, or the use of other technical information contained herein, will not infringe upon existing or future patent rights. The descriptions contained herein do not imply the granting of licenses to make, use, or sell equipment constructed in accordance therewith. Spec and cautions are subject to change without notice. © 2018 Murata Manufacturing Co., Ltd