

DO NOT SCALE FROM THIS PRINT

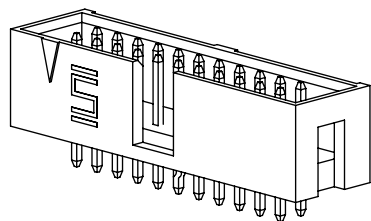

HTST-1XX-XX-XX-D-XX-XX

No OF POSITIONS
 -02 (STRAIGHT ONLY)
 -03 THRU -18, -20, -24,
 -25, -28, -30, -32 & -36

POLARIZATION OPTION
 -XX: INDICATES POSITION OMITTED

LEAD STYLE
 SEE TABLE 1
 & TABLE 2

OPTION
 BLANK: STRAIGHT (STYLES -04 & -05 N/A)
 -RA: RIGHT ANGLE (STYLES -01, -02 & -03 N/A)
 -LL: LOCKING LEAD (STRAIGHT ONLY)
 -LA: -RA OPTION WITH -LL OPTION

ROW SPECIFICATION
 -D: DOUBLE ROW
 (USE HTST-XX-D)

PLATING SPECIFICATION

- G: GOLD, 10 Au / 50 Ni MIN ON CONTACT, 3 Au / 50 Ni MIN ON TAIL
- T: MATTE TIN, CONTACT AND TAIL
- S: SELECTIVE, 30 Au / 50 Ni MIN ON CONTACT, MATTE TIN TAIL
- L: LIGHT SELECTIVE, 10 Au / 50 Ni MIN ON CONTACT, MATTE TIN TAIL
- H: HEAVY GOLD, 30 Au / 50 Ni MIN ON CONTACT, 3Au / 50 Ni MIN ON TAIL
- F: FLASH SELECTIVE, 3 Au / 50 Ni ON CONTACT, MATTE TIN TAIL
- TM: MATTE TIN CONTACT AND TAIL
- SM: SELECTIVE, 30 Au / 50 Ni ON CONTACT, MATTE TIN TAIL
- FM: FLASH SELECTIVE, 3 Au / 50 Ni MIN ON CONTACT, MATTE TIN TAIL
- LM: LIGHT SELECTIVE, 10 Au / 50 Ni MIN, MATTE TIN TAIL

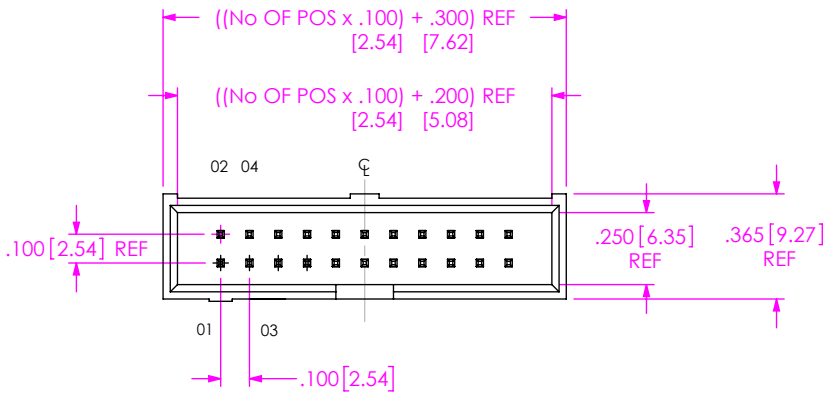

| TABLE 1 | | |
|------------|-------------|---------------|
| LEAD STYLE | "A" | TERMINAL |
| -01 | .480[12.19] | T-1S6-17-XX-2 |
| -02 | .530[13.46] | T-1S6-08-XX-2 |
| -03 | .930[23.62] | T-1S6-11-XX-2 |

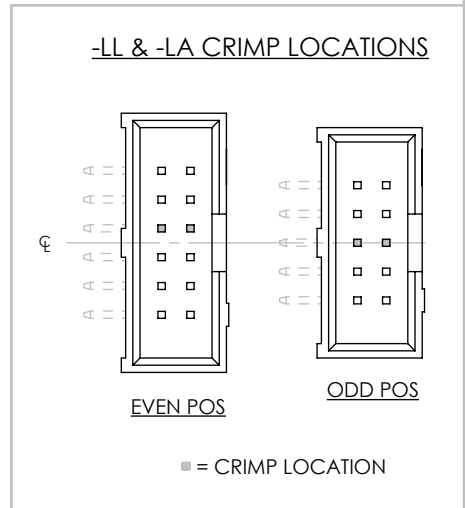
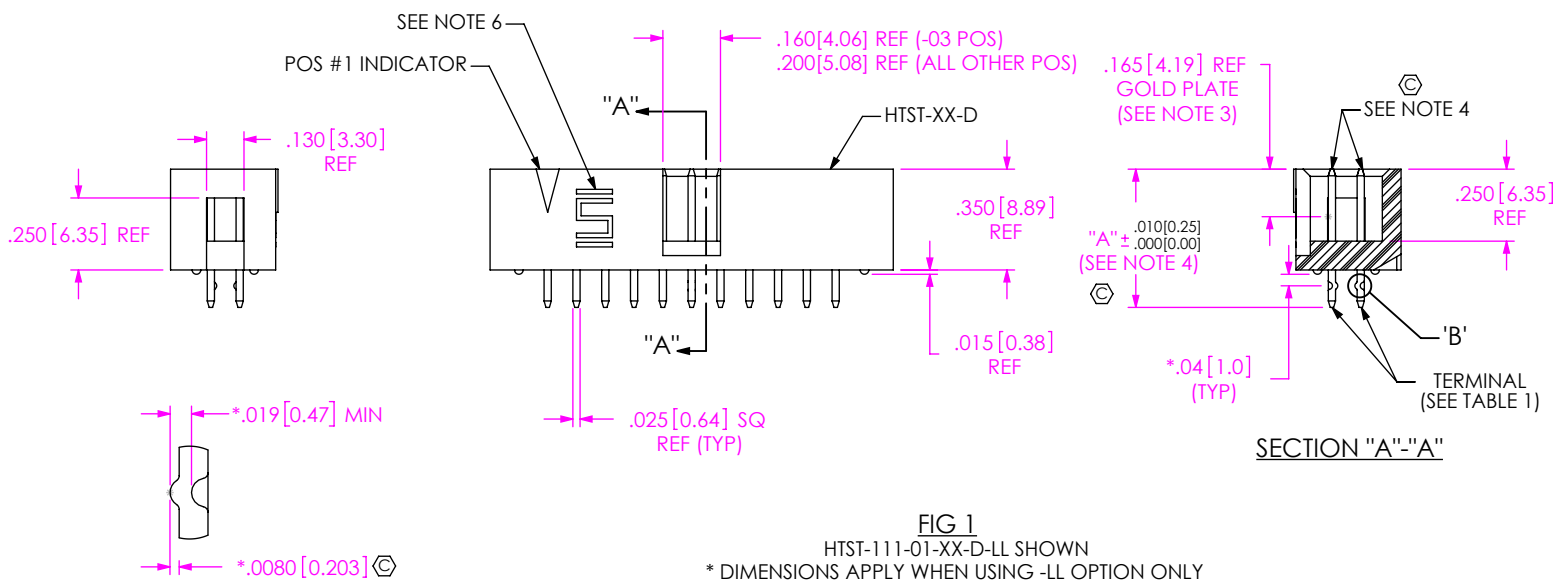

FIG 1
 HTST-111-01-XX-D-LL SHOWN
 * DIMENSIONS APPLY WHEN USING -LL OPTION ONLY

DETAIL 'B'
 SCALE 6 : 1

- NOTES:
1. Ⓢ REPRESENTS A CRITICAL DIMENSION.
 2. TERMINAL PUSHOUT FORCE: 3 lbs.
 3. ASSEMBLE GOLD PLATED END AS SHOWN.
 4. TERMINALS TO BE FLUSH TO .010[.25] BELOW TOP OF SHROUD.

UNLESS OTHERWISE SPECIFIED, DIMENSIONS ARE IN INCHES. TOLERANCES ARE:
 DECIMALS ANGLES
 .XX: ±.01 [.3] 2°
 .XXX: ±.005 [.13]
 .XXXX: ±.0020 [.051]

PROPRIETARY NOTE
 THIS DOCUMENT CONTAINS CONFIDENTIAL AND PROPRIETARY INFORMATION AND ALL DESIGN, MANUFACTURING, REPRODUCTION, USE, PATENT RIGHTS AND SALES RIGHTS ARE EXPRESSLY RESERVED BY SAMTEC, INC. THIS DOCUMENT SHALL NOT BE DISCLOSED, IN WHOLE OR PART, TO ANY UNAUTHORIZED PERSON OR ENTITY NOR REPRODUCED, TRANSFERRED OR INCORPORATED IN ANY OTHER PROJECT IN ANY MANNER WITHOUT THE EXPRESS WRITTEN CONSENT OF SAMTEC, INC.



520 PARK EAST BLVD, NEW ALBANY, IN 47150
 PHONE: 812-944-6733 FAX: 812-948-5047
 e-Mail: info@SAMTEC.com code: 53322

MATERIAL: DO NOT SCALE DRAWING SHEET SCALE: 1.5:1
INSULATOR: LCP, UL 94 VO COLOR: NATURAL
TERMINAL: PHOS BRONZE
 F:\DWG\MISC\MKTG\HTST-1XX-XX-XX-D-XX-XX-MKT.SLDDRW

DESCRIPTION: HIGH TEMP TOP SHROUD TERMINAL STRIP
DWG. NO. HTST-1XX-XX-XX-D-XX-XX
BY: BRATCHER 01/16/04 **SHEET 1 OF 2**

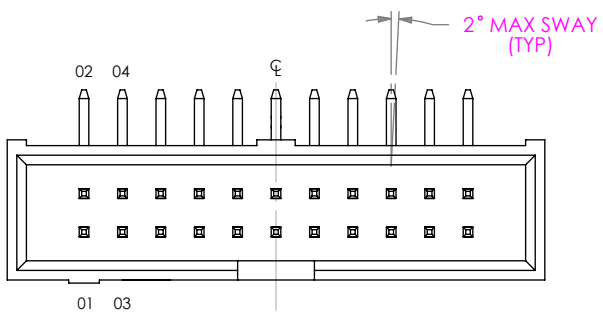
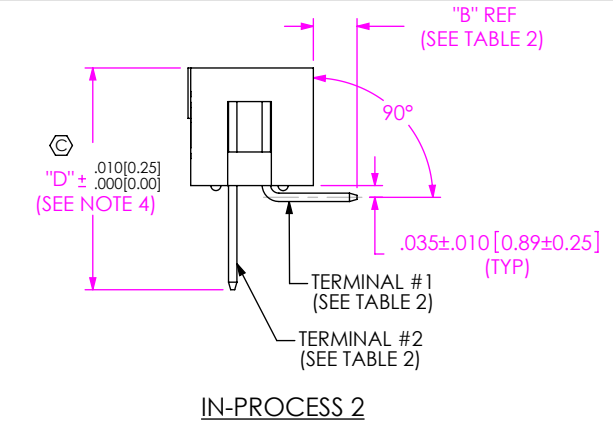
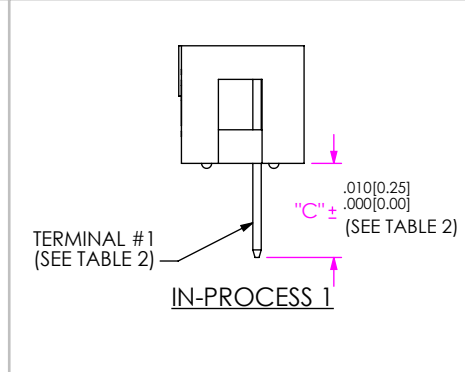
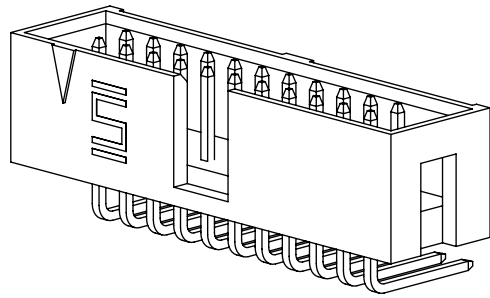
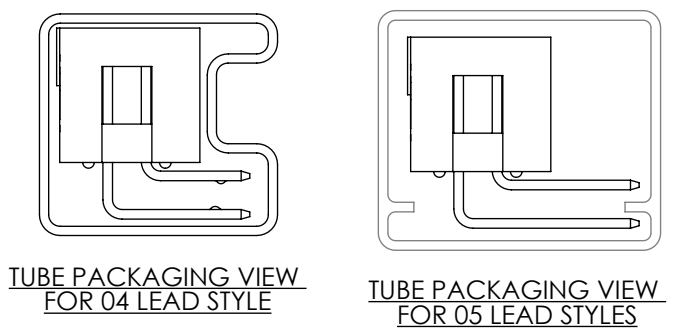
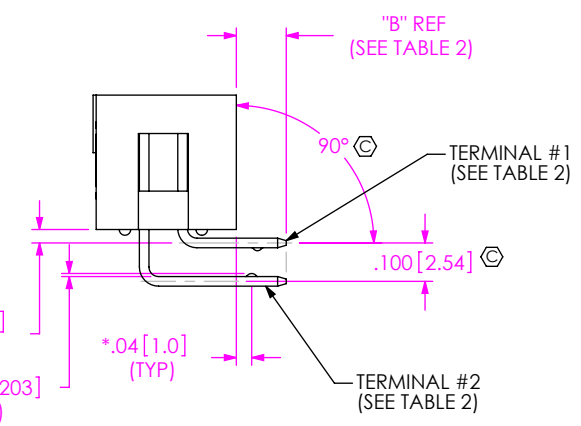
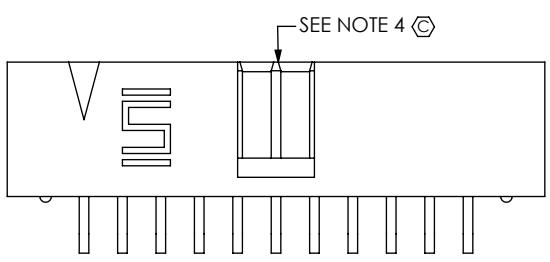

FIG 2
 -RA & -LA OPTIONS
 (HTST-111-04-XX-D-LA SHOWN)
 (SAME AS FIG 1, UNLESS OTHERWISE STATED)
 * DIMENSIONS APPLY WHEN USING -LA OPTION ONLY



| LEAD STYLE | "B" | "C" | "D" | TERMINAL #1 | TERMINAL #2 |
|------------|------------|------------|-------------|---------------|---------------|
| -04 | .130[3.30] | .280[7.11] | .830[21.08] | T-1S6-15-XX-2 | T-1S6-10-XX-2 |
| -05 | .230[5.84] | .380[9.65] | .930[23.62] | T-1S6-09-XX-2 | T-1S6-11-XX-2 |

| Lead Style | Packaging | TUBES | PLUG |
|------------|-----------|-----------------|-------|
| -01 | Bulk | N/A | N/A |
| -02 | Bulk | N/A | N/A |
| -03 | Bulk | N/A | N/A |
| -04 | Tube | PT-1-24-01-40 | TP-13 |
| -05 | Tube | PT-1-24-12T-109 | TP-28 |

PROPRIETARY NOTE
 THIS DOCUMENT CONTAINS CONFIDENTIAL AND PROPRIETARY INFORMATION AND ALL DESIGN, MANUFACTURING, REPRODUCTION, USE, PATENT RIGHTS AND SALES RIGHTS ARE EXPRESSLY RESERVED BY SAMTEC, INC. THIS DOCUMENT SHALL NOT BE DISCLOSED, IN WHOLE OR PART, TO ANY UNAUTHORIZED PERSON OR ENTITY NOR REPRODUCED, TRANSFERRED OR INCORPORATED IN ANY OTHER PROJECT IN ANY MANNER WITHOUT THE EXPRESS WRITTEN CONSENT OF SAMTEC, INC.



520 PARK EAST BLVD, NEW ALBANY, IN 47150
 PHONE: 812-944-6733 FAX: 812-948-5047
 e-Mail: info@SAMTEC.com code: 55322

DO NOT SCALE DRAWING
 SHEET SCALE: 2:1

DESCRIPTION:
 HIGH TEMP TOP SHROUD TERMINAL STRIP
 DWG. NO.

HTST-1XX-XX-XX-D-XX-XX

BY: BRATCHER 01/16/04 SHEET 2 OF 2