

LOC	DIST	REVISIONS					
		P	LTN	DESCRIPTION	DATE	DWN	APVD
GP	00	A1		REVISED PER ECO-09-025699	11-DEC-2009	KK	AEG
		A2		REVISED PER ECO-12-010437	28SEP2012	CJV	DLG
		B		REVISED PER ECO-15-018557	30DEC2015	TX	SH

- 1 MATERIAL: LCP, BLACK.
- 2 MATERIAL: PHOSPHOR BRONZE PER ASTM B 103.
- 3 FINISH: 0.76µm MIN GOLD PLATE PER ASTM B 488, APPLIES TO INTERFACE AREA AND 2.03µm MIN TIN PLATE SOLDER TAILS, ALL OVER 3.81µm MIN NICKEL PLATE PER QQ-N-290.
- 4 DATUM AND BASIC DIMENSION ESTABLISHED BY CUSTOMER.
- 5 WITH KAPTON PLACEMENT DOT INSTALLED.
- 6 PACKAGED IN TUBES.
- 7 PACKAGED IN TAPE AND REEL.
- 8 CONNECTOR PIN IDENTIFIERS: SYMETRICAL VERTICAL CONNECTORS CAN BE APPLIED TO BOARD IN EITHER ORIENTATION.
- 9 FINISH: 0.38µm MIN GOLD PLATE PER ASTM B 488, APPLIES TO INTERFACE AREA AND 2.03µm MIN TIN PLATE SOLDER TAILS, ALL OVER 3.81µm MIN NICKEL PLATE PER QQ-N-290.
- 10 OBSOLETE PARTS: OBSOLETE CIS STREAMLINING PER D.RENAUD/D.SINISI

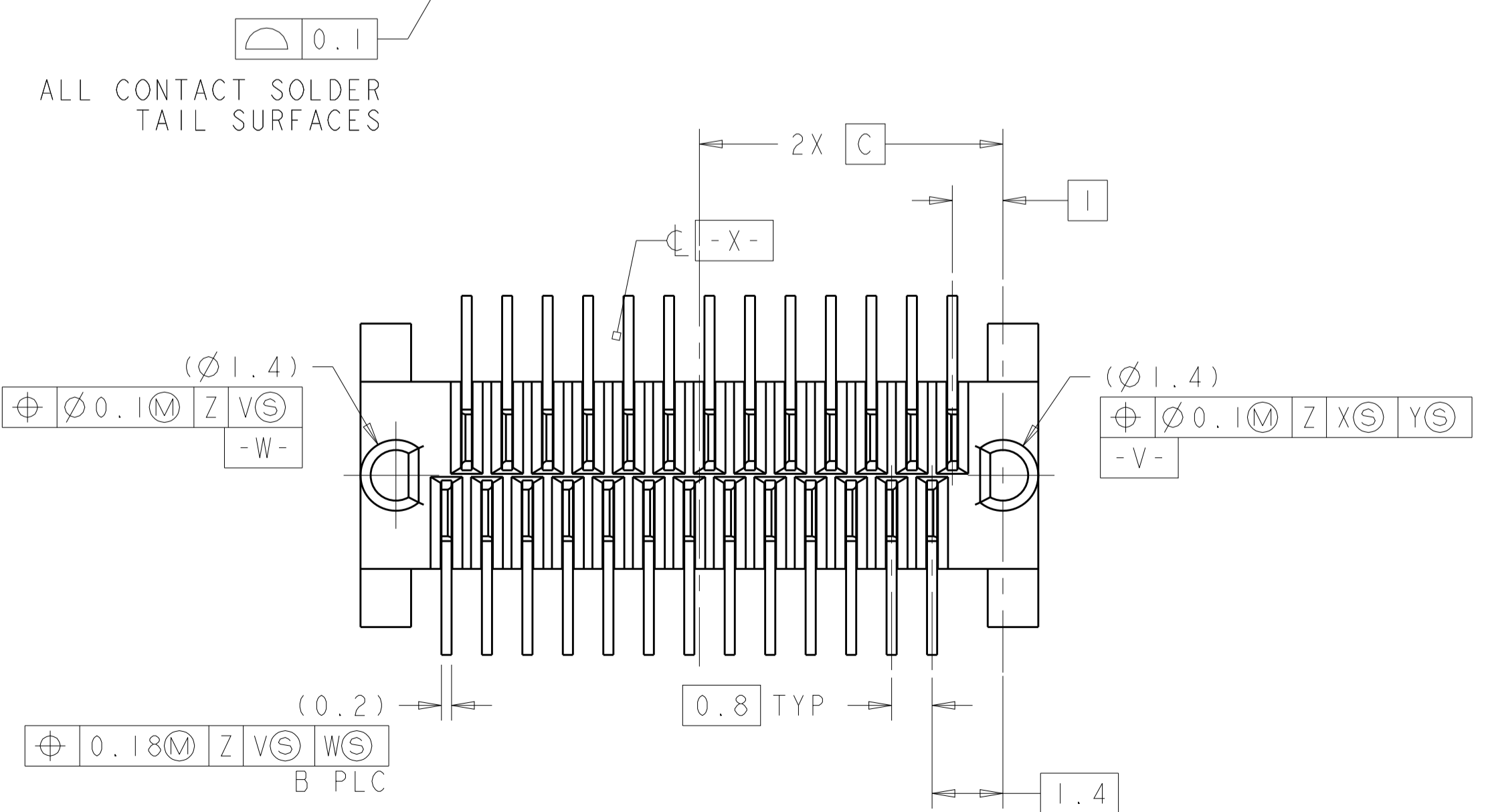
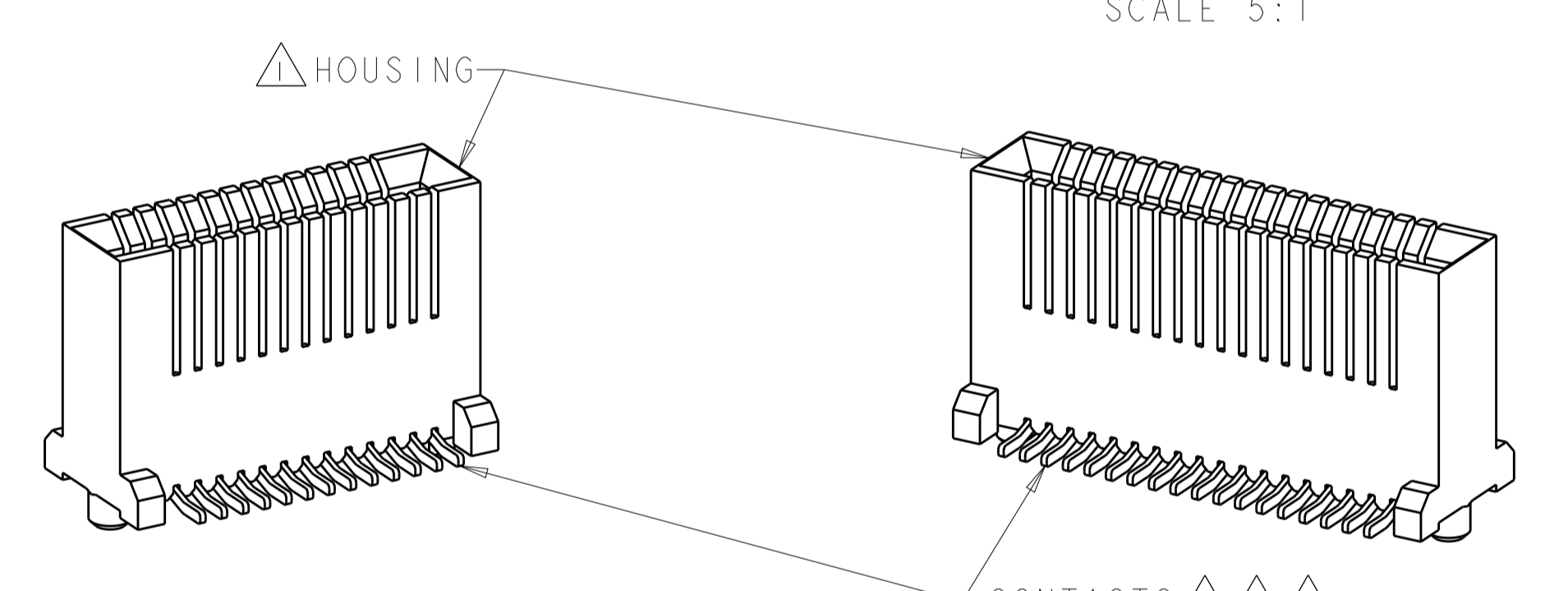
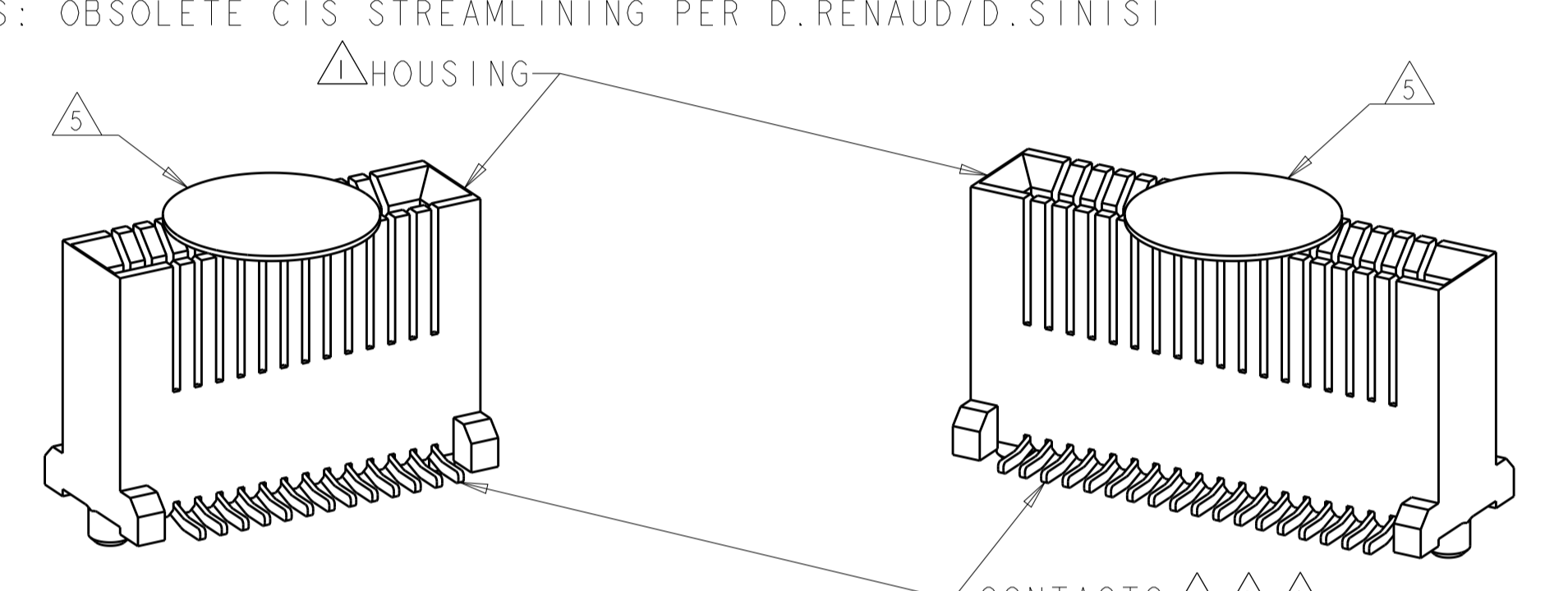
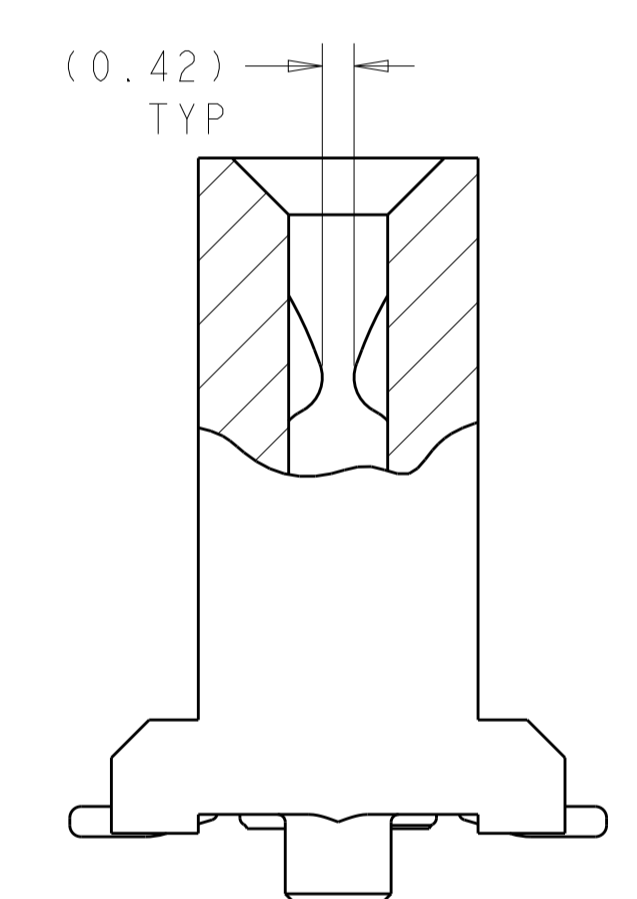
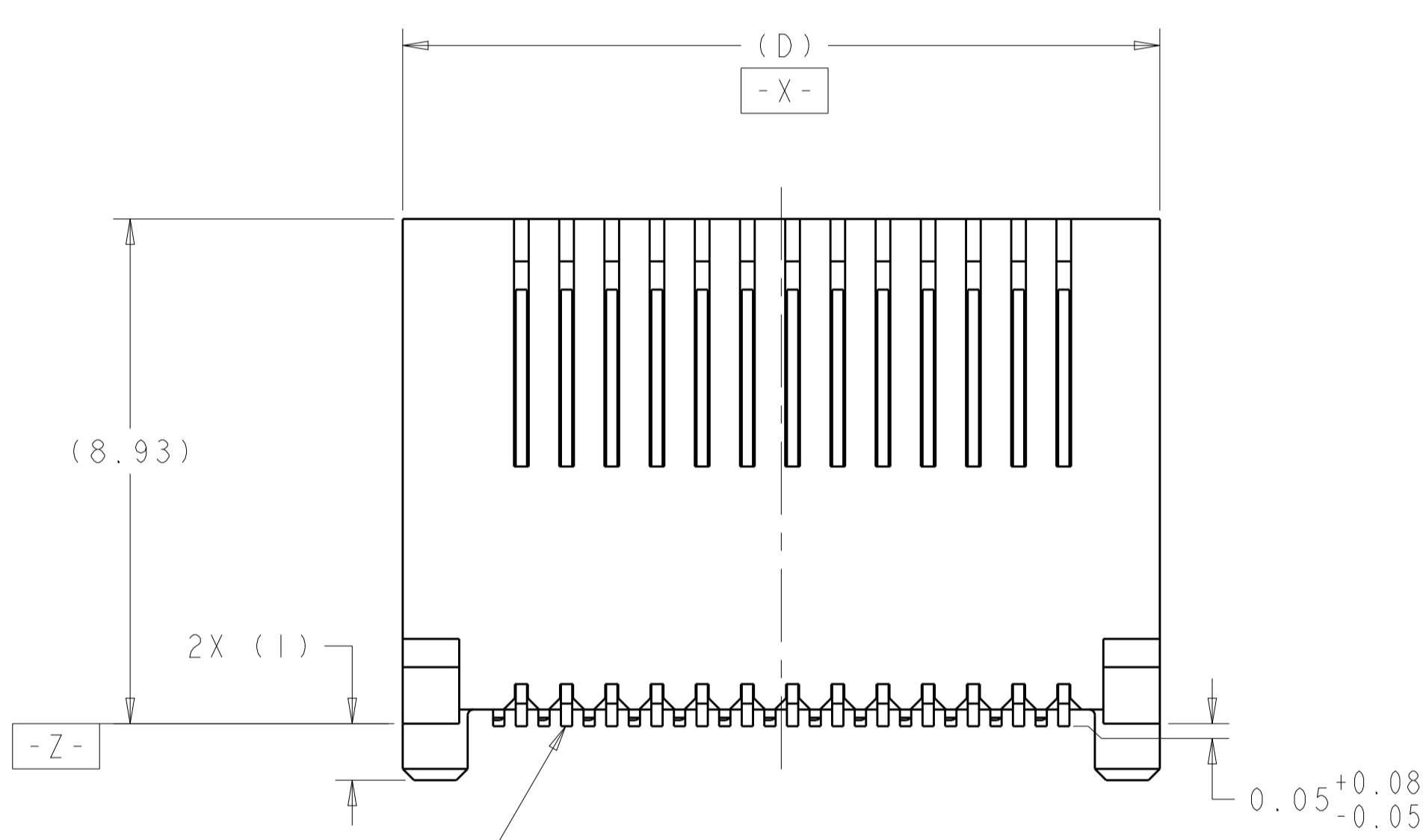
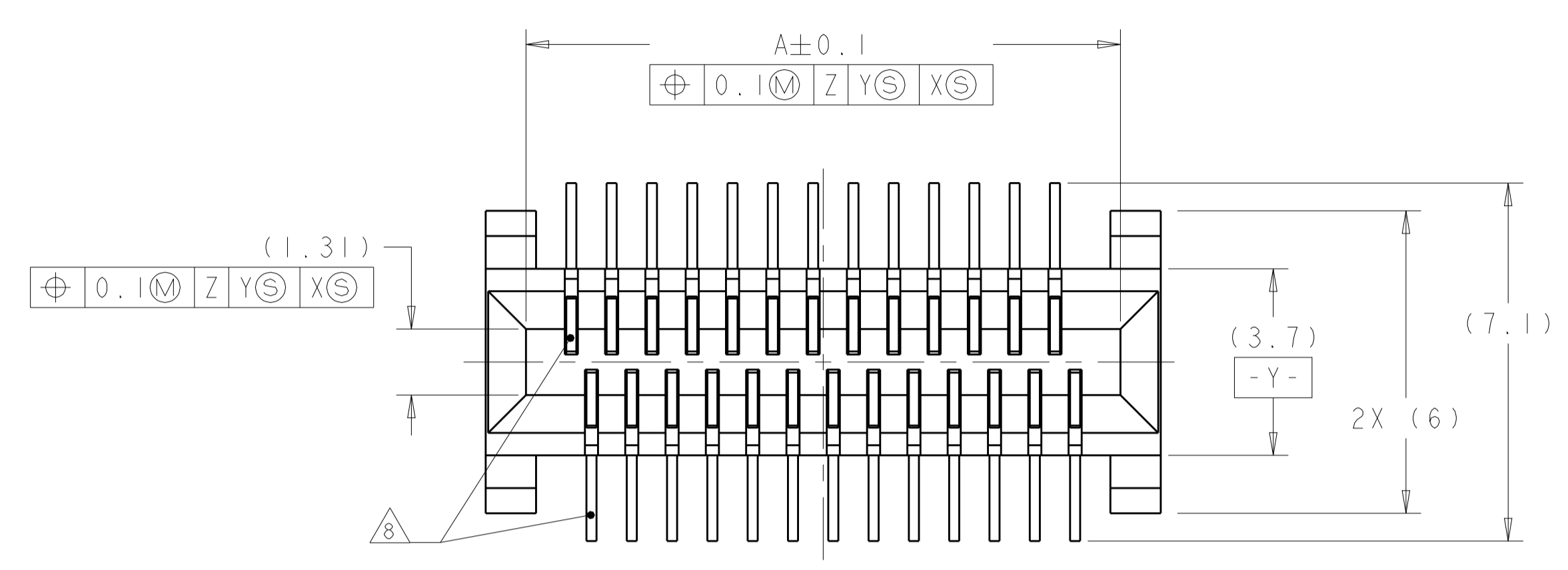

OBSOLETE		7	-	-	-	-	-	-	1888020-6	5	1888020-8	
OBSOLETE		7	-	-	-	-	-	-	1888020-5	5	1888020-7	
OBSOLETE	9	6	36	16	17.4	8	36	15.8	36	-	1888020-6	
OBSOLETE		6	26	12	13.4	6	26	11.8	26	-	1888020-5	
OBSOLETE		7	-	-	-	-	-	-	-	1888020-2	5	1-1888020-0
OBSOLETE		7	-	-	-	-	-	-	-	1888020-2	5	1888020-4
OBSOLETE	3	7	-	-	-	-	-	-	-	1888020-1	5	1888020-3
OBSOLETE		6	36	16	17.4	8	36	15.8	36	-	1888020-2	
OBSOLETE		6	26	12	13.4	6	26	11.8	26	-	1888020-1	
FINISH	PACKAGING	N	E	D	C	B	A	POSN	MADE FROM		PART NUMBER	

THIS DRAWING IS A CONTROLLED DOCUMENT. DIMENSIONING AND TOLERANCING PER ASME Y14.5M-2009.

OWN: M.E. COWHER 01JUL05
 CHK: R.R. HENRY 01JUL05
 APVD: R.R. HENRY 01JUL05

NAME: EVERCLEAR Mini-SAS VERTICAL RECEPTACLE CONNECTOR ASSEMBLY, SURFACE MOUNT
 PRODUCT SPEC: 108-2234
 APPLICATION SPEC: -

SIZE: A1
 CAGE CODE: 100779
 DRAWING NO: 1888020

SCALE: 10:1
 SHEET: 1 OF 2
 REV: B

STE TE Connectivity

LOC		DIST		REVISIONS			
P	LTN	DESCRIPTION	DATE	DWN	APVD		
-	-	SEE SHEET 1	-	-	-		

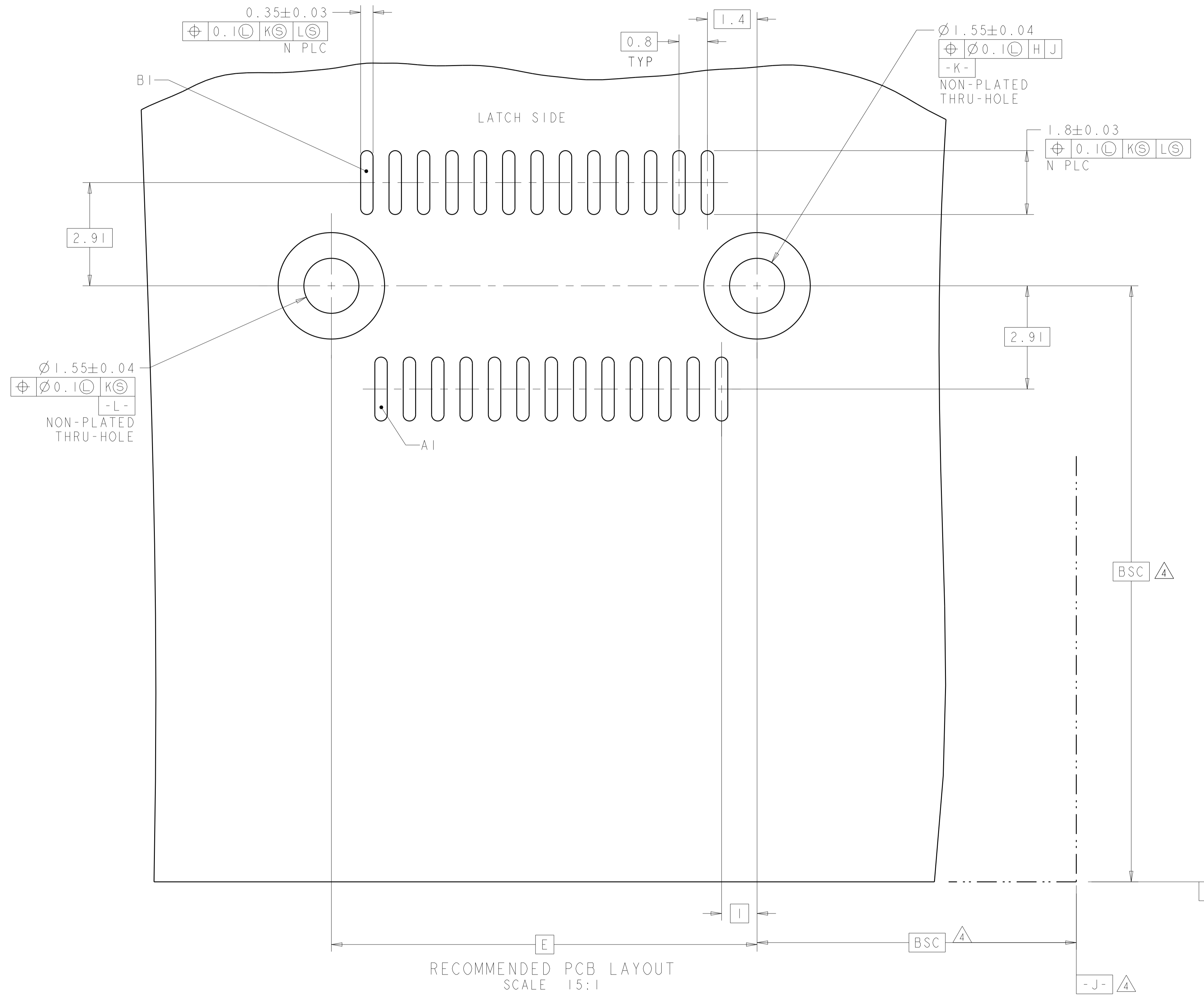

THIS DRAWING IS A CONTROLLED DOCUMENT. DIMENSIONING AND TOLERANCING PER ASME Y14.5M-2009		DWN M. E. COWHER 01 JUL 05	TE Connectivity
DIMENSIONS: mm		CHK R. R. HENRY 01 JUL 05	
TOLERANCES UNLESS OTHERWISE SPECIFIED:		APVD R. R. HENRY 01 JUL 05	NAME EVERCLEAR Mini-SAS VERTICAL RECEPTACLE CONNECTOR ASSEMBLY, SURFACE MOUNT
0 PLC ± 1 PLC ± 2 PLC ± 3 PLC ± 4 PLC ± ANGLES ±		PRODUCT SPEC 108-2234 APPLICATION SPEC	
MATERIAL SEE NOTES		FINISH SEE TABLE	SIZE CAGE CODE DRAWING NO A100779C=1888020
CUSTOMER DRAWING		SCALE 10:1	SHEET 2 OF 2 REV B